

A	
A/C and heater control	94
A/C compressor switch	98
A/C condenser	98
A/C control bezel	99
A/C Duct	99
A/C evaporator core	99
A/C gasket set	98
A/C hose set	99
A/C hose	99
A/C mounting brace	98
A/C shut off	122
A/C tube kit	99
Accelerator cable	58
Accelerator pedal stud assembly	59
Accelerator pedal	58
Air cleaner assembly	57
Alternator bracket	38
Ammeter gauge assembly	41
Angle strips	150
Antenna	100
Anti-rattler kit	130
Arm rest	124
Ash tray knob	121
Ash tray	121
AutoMeter	179
B	
Back-up lamp lens	47
Backup lamp switch	63
Backup light bracket	47
Backup socket assembly	47
Backup switch	47
Ball joint	73
Battery hanger clamp	39
Battery hold down	38
Battery tray	38
Bed front panel	154
Bed patch panel	153
Bed strip bolt kits	152
Bed strips	150-151
Bedside kit	156
Bedside panel	156-157
Bench seats	145
Bezel insert	108
Billet Specialties	182
Blank keys	36
Blower motor	96
Blower motor	99
Blower resistors	96
Boese	193
Body to frame web	97
Bolt kits	171-172
Book and literature	5-9
Brake drums	71
Brake hardware kit	70
Brake light switch	40
Brake line set	68
Brake pad	65
Brake pedal shaft bushing	64
Brake proportioning valve	69
Brake shoe set	70
Break fluid	10
Bubba Bilt	203
Bumper bolt kits	81-82
Bumper bolts	79
Bumper brace covers	81
Bumper brackets	81
Bumper guards	79
Bumper stickers	13
Bumper, glove box	109
Bumpers	79-80
Bumpers, door	136
C	
Cab corner	142
Cab mount bolt set	97
Cab mount set	97
Cab step repair panel	93
Cab to floor support	82
Cameo license lights	48
Car cover	173
Carburetor rebuild kit	59
Cargo light housing	41
Carpet	111
Center console	144
Center dash	108
Choke cable	58
Choke control thermostat	60
Choke knobs	58
Cigarette lighter	102
Circuit board	103
Classic Performance Parts	204
Clock	13
Clutch head screwdriver set	13
Clutch pad	65
Clutch release shaft	25
Clutch shaft bushing	64
Compressor o-ring kit	96
Control arm bushing	73
Control arm shaft kit	73
Cowl kick panel	114
Cowl panel	140, 141
Cowl screen	121
Cowl seal	91
Cross sill	153
Crossmember	153
D	
Dakota Digital	208
Dash cap	122
Dash gauge refacing kit	63
Dash knobs	102
Dash pad mounting kit	121
Dash pad	122
Dash panels	121
Decals	14-23
Defrost vent	105
Defroster cable	93
Defroster hose kit	94
Defroster hose	105
Dial housing	100
Dice	14
Dimmer switch	40
Disconnect switch	39
Distributor rotor	39
Division bar	128
Dome assembly	138
Dome lens	138
Door bottom, inner	123
Door bottom, outer	123
Door cap	131
Door emblems	127
Door felt	129
Door glass	129
Door guards	136
Door handles	135
Door hinge bracket	133
Door hinge grommets	133
Door hinge	132
Door jamb valve	110
Door latch assembly	134
Door lock button	125
Door lock set	133
Door moulding	127
Door panel insert	127
Door panel	125-126
Door pillar panel	140

Door seal kit	131
Door seal retainer	131
Door sills	144
Door weatherstrip	131
Door window switch	110
Doors	123
Drag link assembly	76

E

Electric fuse block	40
Electric-Life	211
Emblem, glove box	109
Emblems	88-90
Emblems, fender	162
Emblems, tailgate	155
Emblems, tailgate	166
Emergency brake boot	61
Engine bolt kit	24
Engine enamel	10
Engine ground strap	39
Exhaust deflector	59
Exterior sunvisor	141
Eye pin and bushing	78
Eyebrow moulding	87

F

Fan shroud	34
Fender brace, front	92
Fender brace, rear	93
Fender dust seal	92
Fender emblems	88-89
Fender patch, front	87
Fender patch, rear	92
Fender skirts	91
Fender welting	91
Fender, rear	92
Fenders, front	86
Filler hose, gas tank	53
Filler kit, gas tank	54
Firewall grommet	104
Firewall insulation	140
Firewall	139-140
Flaming River	216
Floor board	140
Floor mat	147
Floor mats	112
Floor pan	138-139
Floor seals, steering column	76
Flywheel transmission underpan	25
Fold up license bracket	79
Front brake cable	69
Front brake hose	67
Front brake rotor	71
Front end bolt kit	87
Front motor mount 24	
Front roll pan	87
Front spring U-bolt	77
Front wheel cylinder	66
Fuel filter unit	60
Fuel gauge resistor	54
Fuel gauges	56
Fuel line	57
Fuel pumps	60
Fuel tanks	53
Fuse block	40

G

Gas caps, locking	54
Gas tank cover	111
Gas tank filler hose	53
Gas tank filler kit	54
Gas tank sealer	10, 52
Gas tank sending units	54-56
Gas tank strap	54
Gas tanks	53

Gasket set, transmission	61
Gasket, mirror	120
Gasket, park lamp	44
Gasket, sending unit	57
Gate seal	141
Gear shift knobs	61
Generator brush	37
Gennie Shifter	219
Glass channel, tailgate	154
Glass patterns	129
Glass run	130
Glass setting tape	167
Glass, rear corner	137
Glass, rear window	137
Glove box door	109
Glove box emblem	109
Glove box light	109
Glove box liner	108
Glove box lock	109-110
Grill emblems	34
Grill moulding	32
Grills	30-32
Grommet kit	104

H

Handle and latch assembly	154
Handle cups	135
Handle, tailgate	154
Handle, tailgate	154-155
Headlamp assembly	48
Headlamp door	49
Headlamp inner ring	48
Headlamp reflector	48
Headlight knob	40
Headlight switch	40
Headliners	115
Heat duct	99
Heater cable	93-94
Heater control assembly	95
Heater control bezel	95
Heater control levers	95
Heater control rebuild	94
Heater control	94
Heater core	95
Heater fan switch	94
Heater fan	96
Heater gasket set	98
Heater hose kit	94
Heater knob	95
Heater pull switch cable	95
High-low horn assembly	50
Hitch caps	13
Hog ring pliers	147
Hood divider strip	82
Hood front moulding	84
Hood hinge bolt kit	24
Hood hinges	84
Hood lamp	96
Hood latches	85
Hood ornaments	84-85
Hood prop kit	82
Hood seal	91
Hood side emblems	88
Hood springs	83
Hood strips	83
Hoods	82-83
Horn buttons	51
Horn relay	50
Horn retainer	50
Horn retaining kits	51
Hubcaps	72
Hydraulic steering seal kit	74

I

Ididit	222
-------------------------	------------

Ignition and door lock set	37
Ignition ballast resistor	36
Ignition coil	39
Ignition points	39
Ignition switches	36-37
Inner fender	90
Instrument bezel	106-107
Instrument lens	102-103
Insulation	97
Interior trim panel	141
Intermediate brake cable	69

K

Key blanks	36
Kick panel	114
King bolt set	73
Knob kit, radio	101
Knob, air vent	106
Knob, ash tray	121
Knob, cowl vent	105
Knob, wiper	118
Knobs, dash	102
Knobs, headlight	40
Knobs, radio	100

L

Latch and catch assembly	156
Latch control and link	134
License lamp assembly 148	
License plate bracket	79
License plate frame	113-114
Liftgate seals	154
Lock, tailgate	154
Lower kick down rod	63
Lower radiator hose	28

M

Magnetic signs	13
Master cylinder repair kit	65
Master cylinder	65
Master Power Brakes	231
Mirror arms	119-120
Mirror gasket	120
Mirror, rearview	119
Mirrors	119
Moon Eyes	234
Moulding clips	157
Moulding clips	162-163
Moulding clips	88
Moulding	158-162
Mounting blocks	152
Mounting pads, radiator	33

N

Name plate	163
Nylon straps	11

O

Oak bed strips	150
Oil filler cap	35
Oil pressure gauge	35
Old Air Products	235
Outer panel	142

P

Painless	239
Park brake pad	65
Park lamp bezel	43
Park lamp gasket	44
Park lamp lens	43
Park lamp rim	44
Park light housing	43
Park light/turn signal conversion kit	42
Park safe system	14
Parking brake handle	64
Parking lamps	42
Pillar post molding	147

Pitman arm	76
POA valve kit	98
Polishes	11
Power brake booster	65
Prothane	244
Publications	5-9

Q

Quarter patch panel	156
Quarter window gaskets	136

R

Radiator cap	27
Radiator grill panel	34
Radiator hose clamp	26
Radiator hose, lower	28
Radiator hose, upper	29
Radiator inlet hose	26
Radiator mounting pads	33
Radiator overflow tank	29
Radiator support bolts	33
Radiator support cover	29
Radiator support	33
Radiators	27-28
Radio buttons	100
Radio face plate	101
Radio face repair	101
Rag joint	75
Rear axle bushing	70
Rear brake cable	69
Rear brake hose	67
Rear motor mount	63
Rear roll pan	166-167
Rear spring bushing	78
Rear tracking arm bushing	70
Rear wheel cylinder	66
Rocker panels	143
Rocky Hinge	245
Roll pan, rear	166-167
Roof marker lens	42
Rubber molding, windshield	116
Rubber, rear corner	137
Rubber, rear window	137
Running board seal	93
Running boards	143
Rust inhibitor	10

S

Scratch shields	135
Screwdriver set	13
Seal beam retaining ring	50
Sealed beam headlamp	49
Seals	141,142
Seat backs	146
Seat backs	147
Seat belts	145
Seat latch	144
Sending unit gasket	57
Sending units	35
Sending units	54-56
Shaft bushing	76
Shift indicator housing	62
Shift indicator lens	62
Shift indicator pointer	62
Shift levers	61
Shock absorber link	77
Shock absorber	77
Side markers	42
Side vent control	105
Signs	12
Slide lever control	94
Spare tire carrier	79
Spark plug support	37
Speaker cover	101
Speaker	101

Speedometer cable	63
Speedometer gauge	103-104
Speedometer glass lens	63
Speedometer needle	63
Spectre Performance	247
Spinner clock	13
Splash apron	143
Splash aprons	34
Spray paint	10
Spring shackle kits	78
Stake pocket	152
Starter drive	36
Starter floor seal	69
Steering box kit	74
Steering box rebuild kit	76
Steering box	76
Steering column – rebuilt	75
Steering idler are	73
Steering wheels	75
Step plates	93
Striker plate	134
Sunvisor bracket	120
Sunvisors	120-121
T	
Tachometer conversion kit	103
Tachometer	103
Tail lamp assembly	45
Tail lamp bezel	45
Tail lamp bracket	44
Tail lamp gasket	46
Tail lamp housing	45
Tail lamp lens	46
Tail pipe bracket	59
Tailgate appliqué	166
Tailgate chains	155
Tailgate covers	165
Tailgate hinges	155
Tailgate hooks	167
Tailgate latches	155
Tailgate recoiler	156
Tailgate skin	167
Tailgate trunnion	155
Tailgate	164-165, 166
Techalon car cover	173
Temperature gauge assembly	26
Temperature valve	106
Terminal block	41
Thermometer	13
Thermostat	29
Throttle cable	57
Throttle knobs	58
Throttle linkage	58
Tie down ratchets	11
Tie rod ends	74
Tie rod repair kit	74
Tie rod sleeve	73
Tire	70
Total Cost Involved	248
Transmission control rod	62
Transmission cover	139
Transmission gasket set	61
Transmission mount pads	61
Transmission mount	63
Transmission shifter boot	61
Transmission solenoid	64
Trim adhesive	11
Trim ting	71-72
Trim, windshield	117
Truck beds	148-149
T-shirts	14
Turn signal levers	52
Turn signal repair kit	52
Turn signal switches	51

U

Universal ignition switch	37
Upholstery	145-146
Upper filler panel	32
Upper radiator hose	29
Upper support cushion	33

V

Vacuum actuator	99-100
Vacuum advance mechanism	39
Vacuum gauge	103
Valve covers	24
Valve stem caps	72
Vent gasket, cowl	122
Vent gasket, side	122
Vent glass assembly	128
Vent glass	128
Vent handles	129
Vent seals	128
Vent shade	102
Vent window assembly	129
Vent window frame	128
Vintage Air	252
Voltage reducer	110
Voltage regulator	41

W

Walker Radiator Works	263
Washer container	118
Washer pump	118
Water outlet	26
Water pumps	26
Watson's StreetWorks	265
Wheel bearings	74
Wheel cover insert	72
Wheel cylinder kit	66
Wheel cylinder repair kit	66
Wheel housing	157
Wheel Vintiques	269
Windlace retainer	130
Windlace rubber	130
Windlace	147
Window crank	132
Window handle	132
Window moulding	110
Window regulator repair	131
Window regulator	132
Windshield glass	116
Windshield reservoir	106
Wiper arms	117
Wiper blades	117
Wiper knob	118
Wiper motors	117-118
Wiper spacer	118
Wiper switch	106
Wiper switch	119
Wiring grommet	105
Wiring harnesses	168-171





1947 sales folder



6 1/2 x 11 and opens to 18 1/2 x 24 (Sizes may vary)

COLOR SALES FOLDER

Original reprints of the sales folders that were shown and given at the Chevrolet dealership!

1942 Chevrolet Pickup	PBK-100-42 each	6.95
1946 Chevrolet Pickup	PBK-100-46 each	6.95
1947 Chevrolet Pickup	PBK-100-47 each	6.95
1948 Chevrolet Pickup	PBK-100-48 each	6.95
1949 Chevrolet Pickup	PBK-100-49 each	6.95
1950 Chevrolet Pickup	PBK-100-50 each	6.95
1951 Chevrolet Pickup	PBK-100-51 each	6.95
1952 Chevrolet Pickup	PBK-100-52 each	6.95
1953 Chevrolet Pickup	PBK-100-53 each	6.95
1954 Chevrolet Pickup	PBK-100-54 each	6.95
1955 Chevrolet Pickup (1st series)	PBK-100-55A each	6.95
1955 Chevrolet Pickup (2nd Series)	PBK-100-55B each	6.95
1956 Chevrolet Pickup	PBK-100-56 each	6.95
1957 Chevrolet Pickup	PBK-100-57 each	6.95
1958 Chevrolet Pickup	PBK-100-58 each	6.95
1958 Chevrolet Panel Truck	PBK-100-58P each	6.95
1959 Chevrolet Pickup	PBK-100-59 each	6.95
1959 Chevrolet Panel Truck	PBK-100-59P each	6.95
1960 Chevrolet Pickup	PBK-100-60 each	8.95
1961 Chevrolet Pickup	PBK-100-61 each	8.95
1962 Chevrolet Pickup	PBK-100-62 each	8.95
1963 Chevrolet Pickup	PBK-100-63 each	8.95
1964 Chevrolet Pickup	PBK-100-64 each	8.95
1965 Chevrolet Pickup	PBK-100-65 each	8.95
1966 Chevrolet Pickup	PBK-100-66 each	8.95
1967 Chevrolet Pickup	PBK-100-67 each	8.95
1968 Chevrolet Pickup	PBK-100-68 each	8.95

Color Sales Folders cont...

1968 sales folder



1969 Chevrolet Pickup	PBK-100-69 each	8.95
1970 Chevrolet Pickup	PBK-100-70 each	8.95
1971 Chevrolet Pickup, Blazer, Suburban	PBK-100-71 each	8.95
1972 Chevrolet Pickup, Blazer, Suburban	PBK-100-72 each	8.95

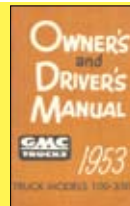
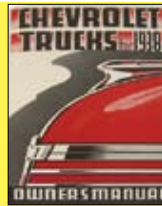

OWNERS MANUAL

You need one of these in your glove box! These manuals are full of handy "How to operate your new truck" tips as well as other neat original facts & warranty information.

1932 pickup owners manual	PBK-300-32 each	8.95
1932 Chevrolet Pickup (267 pages - 5 1/4" x 8")	PBK-300-33 each	8.95
1933 Chevrolet Pickup (288 pages - 5 1/4" x 8")	PBK-300-34 each	8.95
1934 Chevrolet Pickup (63 pages - 5 1/4" x 8")	PBK-300-35 each	8.95
1935 Chevrolet Pickup (64 pages - 5 1/4" x 8")	PBK-300-36 each	8.95
1936 Chevrolet Pickup (51 pages - 5 1/4" x 8")	PBK-300-37 each	8.95
1937 Chevrolet Pickup (63 pages - 5 1/4" x 8")	PBK-300-38 each	8.95
1938 Chevrolet Pickup (63 pages - 5 1/4" x 8")	PBK-300-39 each	8.95
1939 Chevrolet Pickup (62 pages - 5 1/4" x 8")	PBK-300-40 each	8.95
1940 Chevrolet Pickup (63 pages - 5 1/4" x 8")	PBK-300-41 each	8.95
1941 Chevrolet Pickup (55 pages - 5 1/4" x 8")	PBK-300-42 each	8.95
1942 Chevrolet Pickup (56 pages - 5 1/4" x 8")	PBK-300-43 each	8.95
1946 Chevrolet Pickup (57 pages - 5 1/4" x 8")	PBK-300-44 each	8.95
1947 Chevrolet Pickup	PBK-300-45 each	8.95
1948 Chevrolet Pickup	PBK-300-46 each	8.95

Owner Manuals cont...



1947 Chevrolet Pickup (96 pages - 5 1/4" x 8")	PBK-300-47 each	8.95
1948 Chevrolet Pickup (93 pages - 5 1/4" x 8")	PBK-300-48 each	8.95
1949 Chevrolet Pickup (95 pages - 5 1/4" x 8")	PBK-300-49 each	8.95
1949 GMC Chevrolet Pickup (91 pages - 5 1/4" x 8")	PBK-300-49G each	9.95
1950 Chevrolet Pickup (99 pages - 5 1/4" x 8")	PBK-300-50 each	8.95
1950 GMC Chevrolet Pickup (63 pages - 5 1/4" x 8")	PBK-300-50G each	9.95
1951 Chevrolet Pickup (103 pages - 5 1/4" x 8")	PBK-300-51 each	8.95
1951 GMC Chevrolet Pickup (57 pages - 5 1/4" x 8")	PBK-300-51G each	9.95
1952 Chevrolet Pickup (103 pages - 5 1/4" x 8")	PBK-300-52 each	8.95
1952 GMC Chevrolet Pickup (79 pages - 5 1/4" x 8")	PBK-300-52G each	9.95
1953 Chevrolet Pickup (95 pages - 5 1/4" x 8")	PBK-300-53 each	8.95
1953 GMC Chevrolet Pickup (90 pages - 5 1/4" x 8")	PBK-300-53G each	9.95
1954 Chevrolet Pickup (96 pages - 5 1/4" x 8")	PBK-300-54 each	8.95
1954 GMC Chevrolet Pickup (77 pages - 5 1/4" x 8")	PBK-300-54G each	9.95
1955 Chevrolet Pickup (96 pages - 5 1/4" x 8")	PBK-300-55 each	8.95
1955 GMC Chevrolet Pickup (69 pages - 5 1/4" x 8")	PBK-300-55G each	9.95
1956 Chevrolet Pickup (98 pages - 5 1/4" x 8")	PBK-300-56 each	8.95
1957 Chevrolet Pickup (104 pages - 5 1/4" x 8")	PBK-300-57 each	8.95
1958 Chevrolet Pickup (112 pages - 5 1/4" x 8")	PBK-300-58 each	8.95
1959 Chevrolet Pickup (111 pages - 5 1/4" x 8")	PBK-300-59 each	8.95

Owner Manuals cont. on next page



Owner Manuals cont...



1960 Chevrolet Pickup (151 pages - 5 1/4" x 8")	
PBK-300-60 each	8.95
1961 Chevrolet Pickup (104 pages - 5 1/4" x 8")	
PBK-300-61 each	8.95
1962 Chevrolet Pickup (102 pages - 5 1/4" x 8")	
PBK-300-62 each	8.95
1963 Chevrolet Pickup (92 pages - 5 1/4" x 8")	
PBK-300-63 each	8.95
1964 Chevrolet Pickup (98 pages - 5 1/4" x 8")	
PBK-300-64 each	8.95
1965 Chevrolet Pickup (61 pages - 5 1/4" x 8")	
PBK-300-65 each	8.95
1966 Chevrolet Pickup (57 pages - 5 1/4" x 8")	
PBK-300-66 each	8.95
1967 Chevrolet Pickup (57 pages - 5 1/4" x 8)	
PBK-300-67 each	8.95
1968 Chevrolet Pickup (57 pages - 5 1/4" x 8)	
PBK-300-68 each	8.95
1969 Chevrolet Pickup (79 pages - 5 1/4" x 8)	
PBK-300-69 each	8.95
1970 Chevrolet Pickup (79 pages - 5 1/4" x 8)	
PBK-300-70 each	8.95
1971 Chevrolet Pickup (95 pages - 5 1/4" x 8)	
PBK-300-71 each	8.95
1972 Chevrolet Pickup (78 pages - 5 1/4" x 8)	
PBK-300-72 each	8.95
1973 Chevrolet Pickup (73 pages - 5 1/4" x 8)	
PBK-300-73 each	8.95
1974 Chevrolet Pickup (61 pages - 5 1/4" x 8")	
PBK-300-74 each	8.95
1975 Chevrolet Pickup (55 pages - 5 1/4" x 8)	
PBK-300-75 each	8.95
1976 Chevrolet Pickup (72 pages - 5 1/4" x 8)	
PBK-300-76 each	8.95
1977 Chevrolet Pickup (63 pages - 5 1/4" x 8")	
PBK-300-77 each	8.95
1978 Chevrolet Pickup (95 pages - 5 1/4" x 8)	
PBK-300-78 each	8.95
1979 Chevrolet Pickup (70 pages - 5 1/4" x 8")	
PBK-300-79 each	8.95
1980 Chevrolet Pickup (84 pages - 5 1/4" x 8")	
PBK-300-80 each	8.95

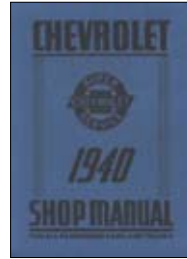
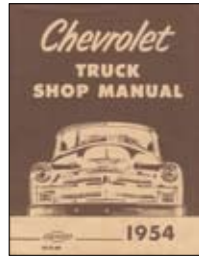

SHOP MANUAL

These are the large textbooks which were supplied to the Chevrolet dealers mechanics. For repair work, this is the book that tells you how to do it all.

1932 Chevrolet Pickup (98 pages - 8 1/2" x 11")	
PBK-400-32 each	9.95
1933 Chevrolet Pickup (110 pages - 8 1/2" x 11")	
PBK-400-33 each	9.95
1934 Chevrolet Pickup (89 pages - 8 1/2" x 11")	
PBK-400-34 each	24.95
1935 36 Chevrolet Pickup (115 pages - 8 1/2" x 11")	
PBK-400-35 each	24.95
1937 Chevrolet Pickup (100 pages - 8 1/2" x 11")	
PBK-400-37 each	24.95
1938 Chevrolet Pickup (270 pages - 8 1/2" x 11")	
PBK-400-38 each	24.95
1939 Chevrolet Pickup (100 pages - 8 1/2" x 11")	
PBK-400-39 each	24.95
1940 Chevrolet Pickup (112 pages - 8 1/2" x 11")	
PBK-400-40 each	24.95
1941 Chevrolet Pickup (150 pages - 8 1/2" x 11")	
PBK-400-41 each	24.95
1942-47 Chevrolet Pickup (85 pages - 8 1/2" x 11")	
PBK-400-42 each	24.95
1947-54 GMC Chevrolet Pickup (50-70 pages - 8 1/2" x 11")	
PBK-400-47 each	24.95
1948-53 Chevrolet Pickup (200 pages - 8 1/2" x 11")	
PBK-400-48 each	24.95
1954 Chevrolet Pickup (450 pages - 8 1/2" x 11")	
PBK-400-54 each	24.95
1955 Chevrolet Pickup (130 pages - 8 1/2" x 11") Includes 1954 and 1955 1st series pickup shop manual.	
PBK-400-55A set	34.95
1955 Chevrolet Pickup (152 pages - 8 1/2" x 11")	
PBK-400-55B each	24.95
1955-59 GMC Chevrolet Pickup (500 pages - 8 1/2" x 11")	
PBK-400-55G each	29.95
1955 2nd series and 1956 pickup (173 pages - 8 1/2" x 11")	
PBK-400-56 set	34.95

Shop Manuals cont...

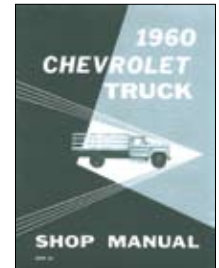
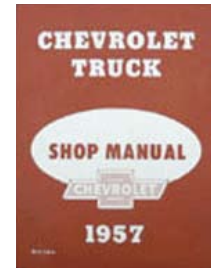

1957 Chevrolet Pickup (104 pages - 8 1/2" x 11")	
PBK-400-57 each	34.95
1958 Chevrolet Pickup (174 pages - 8 1/2" x 11")	
PBK-400-58 each	34.95
1959 Chevrolet Pickup Chevrolet Pickup (168 pages - 8 1/2" x 11")	
PBK-400-59 set	44.95
1960 Chevrolet Pickup (550 pages - 8 1/2" x 11")	
PBK-400-60 each	49.95
1961 Chevrolet Pickup (254 pages - 8 1/2" x 11")	
PBK-400-61 each	49.95
1962 Chevrolet Pickup (301 pages - 8 1/2" x 11")	
PBK-400-62 each	19.95
1963 Chevrolet Pickup (336 pages - 8 1/2" x 11")	
PBK-400-63 each	44.95
1964 Chevrolet Pickup (75 pages - 8 1/2" x 11") Shop manual supplement (must be used with 1963 shop manual)	
PBK-400-64S each	14.95
1965 Chevrolet Pickup (200 pages - 8 1/2" x 11") Shop manual supplement (must use with complete 1963 shop manual)	
PBK-400-65 each	22.95
1966 Chevrolet Pickup (300 pages - 8 1/2" x 11") Shop manual supplement (must use with complete 1963 shop manual)	
PBK-400-66 each	22.95
1967 Chevrolet Pickup (475 pages - 8 1/2" x 11")	
PBK-400-67 each	34.95
1968 Chevrolet Pickup (500 pages - 8 1/2" x 11")	
PBK-400-68 each	34.95
1969 Chevrolet Pickup (230 pages - 8 1/2" x 11")	
PBK-400-69 each	29.95
1970 Chevrolet Pickup (121 pages - 8 1/2" x 11")	
PBK-400-70 each	34.95
1971 Chevrolet Pickup (201 pages - 8 1/2" x 11")	
PBK-400-71 each	24.95
1972 Chevrolet Pickup (175 pages - 8 1/2" x 11")	
PBK-400-72 each	29.95
1973 Chevrolet Pickup (221 pages - 8 1/2" x 11")	
PBK-400-73 each	49.95
1974 Chevrolet Pickup (182 pages - 8 1/2" x 11")	
PBK-400-74 each	69.95



ACCESSORY INSTALLATION MANUALS

This is a quality reprint of the manual issued by Chevrolet to train mechanics to install genuine Chevrolet accessories. You will find step-by-step installation instructions accompanied by exploded view illustrations making every procedure a breeze.

1949 Chevrolet Pickup (112 pages - 8 1/2" x 11")	
PBK-420-49 each	12.95
1950 Chevrolet Pickup (66 pages - 8 1/2" x 11")	
PBK-420-50 each	12.95
1951 Chevrolet Pickup (96 pages - 8 1/2" x 11")	
PBK-420-51 each	12.95
1952 Chevrolet Pickup (96 pages - 8 1/2" x 11")	
PBK-420-52 each	12.95
1953 Chevrolet Pickup (114 pages - 8 1/2" x 11")	
PBK-420-53 each	12.95
1954 Chevrolet Pickup (146 pages - 8 1/2" x 11")	
PBK-420-54 each	19.95
1955 Chevrolet Pickup (85 pages - 8 1/2" x 11")	
PBK-420-55 each	19.95
1957 Chevrolet Pickup (211 pages - 8 1/2" x 11")	
PBK-420-57 each	19.95
1958 Chevrolet Pickup (219 pages - 8 1/2" x 11")	
PBK-420-58 each	19.95
1959 Chevrolet Pickup (280 pages - 8 1/2" x 11")	
PBK-420-59 each	19.95
1960 Chevrolet Pickup (398 pages - 8 1/2" x 11")	
PBK-420-60 each	19.95
1961 Chevrolet Pickup (491 pages - 8 1/2" x 11")	
PBK-420-61 each	21.95
1962 Chevrolet Pickup (461 pages - 8 1/2" x 11")	
PBK-420-62 each	21.95
1963 Chevrolet Pickup (483 pages - 8 1/2" x 11")	
PBK-420-63 each	21.95
1964 Chevrolet Pickup (557 pages - 8 1/2" x 11")	
PBK-420-64 each	21.95
1965 Chevrolet Pickup (525 pages - 8 1/2" x 11")	
PBK-420-65 each	21.95

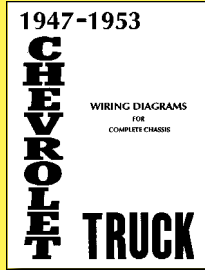

WIRING DIAGRAM MANUAL

Written for Chevrolet dealership mechanics. This manual will help you understand connector configurations, and locate and identify circuits, relays, and grounds. You will not find these wiring diagrams in the factory shop manual.

1942-46 Chevrolet Pickup	
PBK-440-4246 each	6.95
1947-53 Chevrolet Pickup	
PBK-440-4753 each	6.95
1954 Chevrolet Pickup	
PBK-440-54 each	6.95
1955 Chevrolet Pickup	
PBK-440-55 each	6.95
1956 Chevrolet Pickup	
PBK-440-56 each	6.95
1957 Chevrolet Pickup	
PBK-440-57 each	6.95
1958 Chevrolet Pickup	
PBK-440-58 each	6.95
1959 Chevrolet Pickup	
PBK-440-59 each	6.95
1960 Chevrolet Pickup	
PBK-440-60 each	6.95
1961 Chevrolet Pickup	
PBK-440-61 each	6.95
1962 Chevrolet Pickup	
PBK-440-62 each	6.95
1963 Chevrolet Pickup	
PBK-440-63 each	6.95
1964 Chevrolet Pickup	
PBK-440-64 each	6.95
1965 Chevrolet Pickup	
PBK-440-65 each	6.95
1966 Chevrolet Pickup	
PBK-440-66 each	6.95
1967 Chevrolet Pickup	
PBK-440-67 each	6.95
1968 Chevrolet Pickup	
PBK-440-68 each	6.95
1969 Chevrolet Pickup	
PBK-440-69 each	6.95
1970 Chevrolet Pickup	
PBK-440-70 each	6.95
1971 Chevrolet Pickup	
PBK-440-71 each	6.95
1972 Chevrolet Pickup	
PBK-440-72 each	6.95
1973 Chevrolet Pickup	
PBK-440-73 each	6.95
1974 Chevrolet Pickup	
PBK-440-74 each	6.95

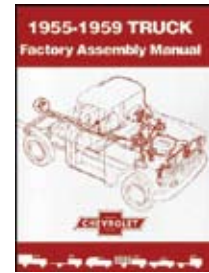

1955-59 Assembly Manual

FACTORY ASSEMBLY MANUAL

These are reprints of the original factory assembly manuals. Each book shows how to assemble your truck from every aspect possible.

1947-54 Chevy (561 pages - 8 1/2" x 11")	
PBK-410-4754 each	29.95
1955-59 Chevy (735 pages - 8 1/2" x 11")	
PBK-410-5559 each	29.95
1960-66 Chevrolet Pickup (521 pages - 8 1/2" x 11")	
PBK-410-6066 each	29.95
1967-72 Chevrolet Pickup (1058 pages - 8 1/2" x 11")	
PBK-410-6772 each	39.95



Show off your truck!

Give your baby the TLC it deserves with our great selection of items!





Speciality Books • Speciality Books • Speciality Books • Speciality Books • Speciality Books •

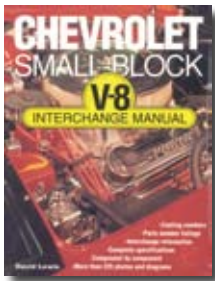

CHEVROLET SMALL BLOCK V8 INTERCHANGE MANUAL

By David Lewis

This is an invaluable text packed with photos and illustrations detailing All the universal Chevy parts that can be interchanged among different models. This is a must for any individual learning about Chevrolet or being your own home mechanic. (8 3/8 x 11", sftbd, 143 pgs, 224 illus, 19 diagrams)

BK-500-A1 each 39.95

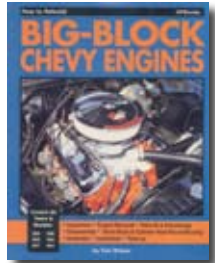

HOW TO REBUILD YOUR BIG BLOCK CHEVY

By Ben Watson

Clear concise text guides you through each engine rebuilding step. Includes complete specifications and more than 500 photos, drawings, charts and graphs. Covers troubleshooting, parts reconditioning and engine assembly. Tells you how to do a complete overhaul or a simple parts swap. One complete chapter on parts identification tells how to interchange parts for improved durability or performance. Includes comprehensive specifications and casting numbers. (sftbd, 8 3/8 x 11" 160 pgs, over 500 b&w illus.)

BK-500-A10 each 29.95

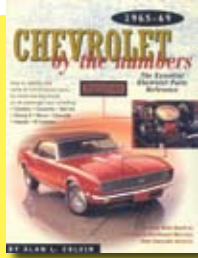

1965-69 CHEVROLET BY THE NUMBERS

By Alan L. Colvin.

Subtitled: How To Identify and Verify All V8 Drivetrain Parts for Small and Big Blocks. Restoring your Chevy to original factory specs? Avoid buying and being sold the wrong parts. Find the casting numbers that correspond to your car's VIN. Determine whether your car has been authentically restored with this never-before seen information from the Chevrolet archives. Essential for Chevrolet restorers. (sftbd, 8 3/8 x 11", 335 pgs, 398 b&w illus.)

BK-500-A15 each 34.95

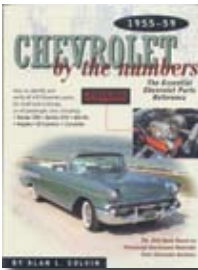

1955-59 CHEVROLET BY THE NUMBERS

By Alan L. Colvin.

Subtitled: How To Identify and Verify All V8 Drivetrain Parts for Small and Big Blocks. Restoring your Chevy to original factory specs? Avoid buying and being sold the wrong parts. Find the casting numbers that correspond to your car's VIN. Determine whether your car has been authentically restored with this never-before seen information for the Chevrolet archives. Essential for Chevrolet restorers. (sftbd, 8 3/8 x 11", 240 pgs, 720 b&w illus.)

BK-500-A18 each 34.95



1960-64 CHEVROLET BY THE NUMBERS

By Alan L. Colvin.

Subtitled: How To Identify and Verify All V8 Drivetrain Parts for Small and Big Blocks. Biscayne, Bel Air, Impala, Chevy II, Chevelle & Corvette. Restoring your Chevy to original factory specs? Avoid buying and being sold the wrong parts. Find the casting numbers that correspond to your car's VIN. Determine whether your car has been authentically restored with this never-before seen information from the Chevrolet archives. Essential for Chevrolet restorers. (sftbd, 8 3/8 x 11", 291 pgs, 200+ b&w illus.)

BK-500-A19 each 34.95

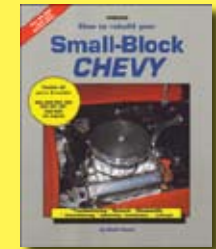

HOW TO REBUILD YOUR SMALL BLOCK CHEVY

by David Vizard

A step-by-step guide to rebuilding Small-block Chevy engines, All makes and models, including All sizes from 283 to 350 cubic-inches. Focuses on rebuilding Small-block Chevy engines back to stock, factory specs using stock, factory parts, without models. (Revised. sftbd, 8 1/2 x 11", 168 pgs., 400 b&w illus.)

BK-500-A8 each 29.95

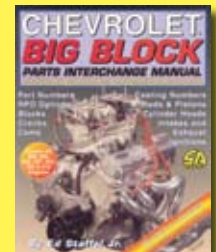

CHEVROLET BIG BLOCK PARTS

By Edward J. Staffel, Jr.

Beginning with the earliest big blocks through present models, this work provides complete part interchange information. Includes factory part numbers, casting marks, production histories, suppliers, performance capabilities of various components, and more. (sftbd, 8 3/8 x 10 7/8", 128 pgs, 300 b&w illus.)

BK-500-B10 each 21.95

**Impress
your friends with
the best in Chevrolet
Pickup knowledge.
Give these great
books a try!**



Speciality Books • Speciality Books • Speciality Books • Speciality Books • Speciality Books •

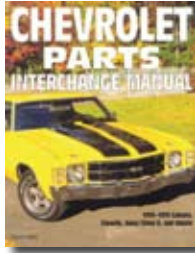

CHEVROLET PARTS INTERCHANGE MANUAL

By Paul Herd
An invaluable listing of interchangeable line parts for Camaro, Chevelle, Impala, and Chevy II-Nova. Find matching parts for your Camaro, Chevelle, Nova, and Chevy II. Looking for a gas tank for a '67 Camaro? Look up the car in this book and under gas tank you'll find a listing of interchangeable parts. This essential book Allows you to find parts easily, and save some money in the process! (sftbd, 8 x 10 5/8", 256 pgs., 167 b&w ill)

BK-500-B14 each 29.95

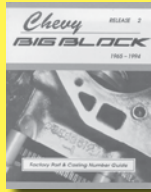

CHEVROLET FACTORY PART & CASTING NUMBER GUIDES: CHEVROLET BIG BLOCK 1965-74

Finally, a series of pocket-sized books that puts part and casting numbers at your fingertips. Part numbers by number and group, casting numbers by number and year. Insure authenticity, know what you're buying, and save time and money by not chasing after the wrong parts. Perfect for restorers. (sftbd, 98 pgs, 4-1/4x 5-1/4")

BK-500-B2 each 24.95

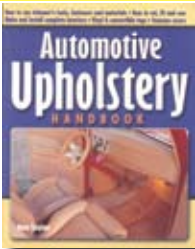

AUTOMOTIVE UPHOLSTERY HANDBOOK

By Don Taylor
Learn to make and install complete interiors in your car, truck or van! Taylor teaches you how to sew like the experts and avoid costly mistakes. Learn to re-cover and build bench or bucket seats, make headliners and carpets, plus how to build boat seats from scratch! Materials are described with specific recommendations for vinyl, cloth, velvet, leather, nimbus, panel board, etc. Indispensable for anyone interested in upholstery. (Revised. sftbd, 8 1/2 x 11", 232 pgs, 550+ b&w ill)

BK-500-B5 each 39.95

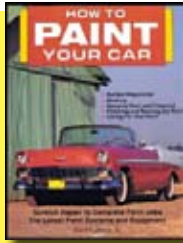

HOW TO PAINT YOUR CAR

By David H. Jacobs, Jr
Every step from sanding to waxing is fully explained and illustrated in this easy-to-follow guide. Paint chemistry, prep work, drying, rubbing out, problem solving and more for simple touch-ups or complete jobs. The ultimate guide to autobody painting! (sftbd, 8 1/2 x 11", 160 pgs, 350 b&w ill.)

BK-500-HPC each 39.95

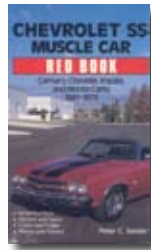

CHEVROLET SS MUSCLE CAR RED BOOK

By Peter C. Sessler
A complete and accurate statistical guide to the extremely popular Super Sport Chevys. 1967-72 Camaro SS; and 1965-73 Chevelle SS; and 1962-70 Impala SS. Colors, options, serial numbers, production totals, specs and facts. A vital fact book for collectors, restorers and enthusiasts. Similar to the popular Corvette black book. (sftbd, 4 1/2 x 7 1/2", 160 pgs, 24 ill.)

FBK-500-B15 each 19.95



CHEVY TRUCK ID NUMBERS

By Cars & Parts
Features Pickups, Suburbans, and El Caminos. How to find and decode vin tags, color codes, options, transmission codes, trim codes, and much more. An excellent aid in restoration. Very valuable in determining authenticity. (sftbd, 8 x 10 1/4", 229 pgs, 156 b&w ill.)

PBK-500-C2 each 34.95

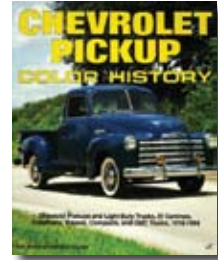

CHEVY PICKUP COLOR HISTORY

By Tom Brownell & Mike Mueller
A superb color history on Chevrolet's pickup trucks from 1918-1994, including El Caminos, Suburbans, Blazers, compacts, and GMC trucks. Traces the trends in truck styling and focuses on the particularly significant eras. (sftbd, 9x 10 1/2", 128 pgs, 24 b&w ill., 99 color.)

PBK-500-C5 each 24.95

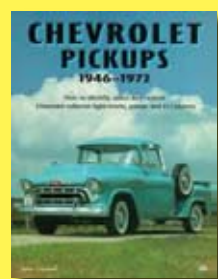

CHEVROLET PICKUPS 1946-72

By John Gunnell
Subtitled: How To Identify, Select and Restore Chevrolet Collector Light Trucks, Panels and El Caminos. The first and most complete book to cover Pickups. Packed with over 200 photos and detailed information on design, history, important differences, unique features, what to look for when buying one, and how to restore it. (sftbd, 8 1/2 x 11", 192 pgs, 200 ill.)

PBK-500-D1 each 26.95

Books also make great, fun gifts! Ask about our All-occasion gift certificates!

Visit www.classicchevroletparts.com for All your Chevrolet Pickup needs (and wants!)

ACCESSORIES & DECALS



**Give aluminum
a new look!**

CAST ALUMINUM GRAY SPRAY PAINT

Gives aluminum a new look -
11 oz. spray can

PT-95-CA each 3.95



CAST IRON SPRAY PAINT

11 oz. spray can

PT-95-CIG each 4.95



**defeats high
temps**



GRAY HIGH TEMP. HIGH GLOSS ENGINE ENAMEL

Quart

PT-95-GRY each 33.95

**defeats high
temps**

HIGH HEAT PAINT

(Aluminum) Withstands 1200 degrees
- 11 oz. spray can

PT-95-HTA each 4.95

(Black manifold) Withstands up to 1600 degrees.
11 oz. spray can

PT-95-HTB each 4.95



SILICONE BRAKE FLUID

This is the end of condensation in your brake
system! No more internal rust!
All years/models with hydraulic brakes

M-2141-SBF each 24.95

GAS TANK ETCH

An excellent prep for your gas tank
before introducing gas tank sealer.
Will remove light buildup of rust
inside tank. Leaves a gray phosphate
coating. 1 pint is good for about a 30
gallon tank.

(Replaces # A-9001-GTE)

B-3000-GTE each 11.95



**World's best
Gas Tank
Sealer!**

ALCOHOL RESISTANT GAS TANK SLOSHING COMPOUND SEALER

World's No. 1 Gas Tank Sealer. Impervious to All
fuel types. Over 2,000,000 sold to date. This is
the best way to repair and restore your fuel tank.
Simple application, includes extensive applica-
tion information and product information sheet.
Will seal pinhole leaks and prevent rusting. 1
Quart.

(Replaces #A-9001-ALR)

B-3000-ALR each 27.95



ORIGINAL SILVER RALLY WHEEL PAINT

Used on GM rally wheels. Two cans
recommended for painting 4 wheels.

12 oz. Can.

1967-81 Chevrolet

PT-95-RW each 24.95



**Check this
out!**



BATTERY MAT

Made of super absorbent polypropylene needle
punch felt, w/one side heat treated to give it ad-
ditional strength. Designed to lay in the bottom of
your battery tray.

Soaks up acid from your battery. (Cut to fit.)

M-96-BMAT each 5.95

**Strip now,
paint later!**

RUST INHIBITOR

Rust inhibitor Allows you to strip now & paint
later. Thin coat protects metal from the weather.
1 gallon.

M-96-RIG gal. 45.95



**super
handy!**



MAGIC DUSTER

Professionally removes surface dust from your
car Complete with storage bag.

M-96-MD each 19.95

Meguiar's

**Like
nothing else!**



MEGUIAR'S QUICK DETAILER

Mist & wipe. 16 oz. spray bottle

M-96-MQD each 7.95

MEGUIAR'S QUICK WAX

16 oz. spray bottle

M-96-MQW each 7.95

MEGUIAR'S SOFT WASH GEL

16 oz. bottle.

M-96-MSW each 5.95

We accept Visa, Master Card, and Discover.



ACCESSORIES & DECALS



PLASTIC AND EMBLEM ADHESIVE

Excellent clear adhesive for plastic repair & emblem application. Use for plastic or metal adhesive, interior rigid plastic, tail light lens repair, vinyl side mouldings or upholstery. 5 oz. tube
M-96-EA each 7.95

Car Hauling Supplies

NYLON AXLE STRAPS



These are a must for anyone who hauls or does any transporting of vehicles. These eliminate the scratching of paint when hauling or trailering your car or pickup. These are a very Small investment for safety and security. Complete with mid-hooks. 24" x 1-3/4" in size.

M-96-NAS each 11.95



POLY RATCHET TIE DOWNS

Matches the M-96-NAS axle straps. Comes with 6 foot straps that hold 5,000 lbs. dead weight. These are a must to ensure safety and security to your project when hauling or trailering from one place to another. Comes with a 1-year warranty against any ratchet defects.

M-96-NRTD each 32.95



**Be sure to stop by our store in Oklahoma City!
8723 S. Interstate 35 Oklahoma City, OK 73149**



MR. BUFFER METAL POLISH

12 oz container
M-99-MB 19.95



SIMICHROME POLISH

(metal polish), 1.76 ozs.
M-99-SP each 10.95



3M SUPER WEATHERSTRIP & GASKET ADHESIVE

This is a gelled, non-stringing, yellow adhesive for bonding paper, cork, or rubber gaskets. Easy clean-up, easier removal, and long lasting. Resistant to gasoline, oil, ethylene glycol, as well as other auto fluids.
5 oz. tube
M-96-SGA each 8.95



3M GENERAL TRIM ADHESIVE

Excellent for fabrics, upholstery, foam, jute pads, carpets, rebonding vinyl top sections, etc. Has adjustable spray pattern, high in strength and doesn't require shaking or agitation before using. Rapid-drying, light-colored and provides good heat resistance. 8 oz. aerosol
M-96-TA8 each 8.95



3M BLACK WEATHERSTRIP ADHESIVE

Ideal for any rubber seals - door seals, heater seals etc. 5 oz. tube
M-96-WA each 9.95



3M WOODGRAIN & STRIPE ADHESIVE REMOVER

This removes the lasting, tacky adhesive residue left after removing the stripes or woodgrain mouldings on your truck. Jelly-like consistency keeps remover in place on vertical surfaces to promote fast action when sprayed from the aerosol can. Saves on repair & repaint of metal surfaces. (18 oz. aerosol can)
M-96-WSAR each 17.95



3M WOODGRAIN & STRIPE REMOVER

For removing woodgrain vinyl and vinyl stripes from acrylic enamel surfaces. Jelly like consistency keeps remover in place on vertical surfaces to promote fast action when sprayed from the aerosol can. Saves on repair & repaint. (18 oz. aerosol can)
M-96-WSR each 17.95



CHEVY SUEDE KEY FOBS

Camaro (All)
M-96-CAKF each 2.50
Chevrolet suede key fob
M-96-CKF each 2.50
Chevy truck suede key fob
M-96-CTKF each 2.50
El Camino suede key fob
M-96-ECKF each 2.50
GMC truck suede key fob
M-96-GMKF each 2.50
Z-28 Camaro suede key fob
1967 81 Camaro
M-96-ZKF each 2.50



ACCESSORIES & DECALS



I'D RATHER PUSH MY CHEVY THAN BE CAUGHT DRIVING A FORD®

Aluminum sign blue on white - (12 x 18)

AS-99-2022 each 14.95

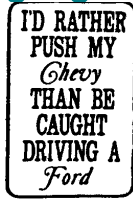

THE DIFFERENCE BETWEEN MEN AND BOYS IS THE PRICE OF THEIR TOYS

Aluminum sign - blue on white - (12 x 18)

AS-99-2024 each 16.95



DON'T EVEN THINK OF PARKING HERE

Aluminum sign red on white - (9 x 12)

AS-99-807 each 14.95



DON'T MESS WITH CHEVY

Aluminum sign Red on white - (9 x 12)

AS-99-834 each 14.95



CHEVY PARKING ONLY OTHERS WILL BE TOWED

Aluminum parking sign - red on white - (12 x 18)

AS-99-A479 each 14.95



GMC PARKING ONLY ALL OTHERS WILL BE TOWED

Aluminum parking sign - red on white - (12 x 18)

AS-99-A394 each 14.95



TRUCK PARKING ONLY - OTHERS WILL BE TOWED

Aluminum parking sign - red on white - (12 x 18)

AS-99-A438 each 14.95



BIG KID'S TOYS PARKING ONLY ALL OTHERS WILL BE TOWED

Aluminum sign (12 x 18)

AS-99-A450 each 14.95



ATTITUDES ADJUSTED WHILE YOU WAIT

Aluminum sign (blue on white, 12" x 18")

AS-99-2040 each 16.95

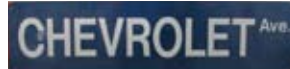

CHEVROLET AVENUE TIN STREET SIGN

(6 x 24)

AS-99-CHA each 39.95

CLASSIC CHEVY DRIVE TIN STREET SIGN

(6 x 24)

AS-99-CCD each 39.95



SUPER CHEVROLET SERVICE

Tin sign, (round 12")

S-99-S112 each 24.95



SUPER CHEVROLET SERVICE

Porcelain sign, double sided, blue & gold, white (25" x 33")

ES-99-SES each 299.95

GMC SALES & SERVICE

Tin sign, double sided, flange style (15' x 17')

AS-99-GSS each 39.95



CHEVROLET POWERED FOR PERFORMANCE ENGINEERED FOR ECONOMY

Tin sign (15' x 8')

AS-99-CH each 19.95



WE USE GENUINE CHEVROLET PARTS

Porcelain 17" dia. flange sign, double sided.

PS-99-GCP each 69.95



WE USE CHEVY PARTS

Tin flange sign, double sided, 12" diameter.

S-99-S each 19.95



CHEVY BOWTIE SIGN

Porcelain, 16 x 48" diameter

S-99-BT each 249.95



CHEVY SALES & SERVICE SIGN

Tin, double sided, flange style (15' x 17')

AS-99-CSS 39.95



OK SIGN

Porcelain, double sided, 24" diameter

S-99-OK each 249.95

GMC TRUCK ROUND SIGN

GMC general motors trucks round sign (7")

1932-72 GMC Chevrolet Pickup

S-99-S32 each 24.95





ACCESSORIES & DECALS

CHEVROLET BEANIE BEAR

9 x 6"
M-99-CBR each 7.95

Available in the following colors...

Please specify when ordering!

- Chevy orange
- navy blue
- red
- gray
- hunter green
- white

Makes a great gift for your little Chevy fan!



Availability of colors may vary. We reserve the right to substitute colors.



YOU DRIVE A FORD®, HA! HA! HA!

(13" x 3")
BS-190-63 each 3.00



YOU DRIVE A MOPAR HA! HA! HA!

(13" x 3")
BS-190-65 each 3.00

I'D RATHER EAT WORMS THAN DRIVE A FORD!

I'D RATHER EAT WORMS THAN DRIVE A FORD®

(12-1/4 X 2-1/2)
BS-190-66 each 3.00

I'D RATHER EAT WORMS THAN DRIVE A MOPAR!

I'D RATHER EAT WORMS THAN DRIVE A MOPAR

(12-1/4 X 2-1/2)
BS-190-68 each 3.00

FRIENDS DON'T LET FRIENDS DRIVE FORDS

FRIENDS DON'T LET FRIENDS DRIVE FORDS®

(12-1/4 X 2-1/2)
BS-190-70 each 3.00

FRIENDS DON'T LET FRIENDS DRIVE MOPARS

FRIENDS DON'T LET FRIENDS DRIVE MOPARS

(12-1/4 X 2-1/2)
BS-190-71 each 3.00



SEE THE U.S.A. IN YOUR CHEVROLET

(12-1/4 X 2-1/2)
BS-190-72 each 4.00

Magnetic Signs

All are 5-1/2 x 3"



LOOK, BUT PLEASE DON'T TOUCH

MM-200-2 each 4.00

LOOK AND ENJOY, BUT PLEASE DON'T TOUCH

MM-200-3 each 4.00

YOU TOUCHA 'DIS MACHINE, I SMASHA YOU FACE

MM-200-5 each 4.00

LOOK, BUT PLEASE DON'T TOUCH MY CLASSIC CHEVY

MM-200-9 each 4.00

GENUINE CHEVY MECHANIC WORKS HERE

MM-200-214 each 3.00



HITCH CAP - CHEVY BOWTIE

Chevy bowtie on ultra strong ABS plastic foil facing. Custom look, fits 2" hitches. Includes retainer pin.

M-99-HCBT each 13.95



HITCH CAP - USA FLAG

Red, white & blue US flag on ultra strong ABS plastic foil facing. Custom look, fits 2" hitches. Includes retainer pin.

M-99-HCRWB each 13.95



DOUBLE BUBBLE GENUINE CHEVY CLOCK

15" diameter, with rounded (bubble) type face. Lights up.

M-96-DBC each 199.95

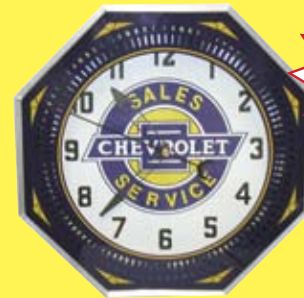

While supplies last!

NEON CHEVROLET SPINNER CLOCK

A perfect addition to any shop, home or office. Rotating neon that actually tells time. A perfect reproduction! 18" in diameter, made in the USA.

M-96-NEC each 349.95



Cool!

CHEVY THERMOMETER

Approx. 5" x 17"

M-99-TH each 34.95

need one of these?



CLUTCH HEAD SCREWDRIVER SET

4 pieces

M-100-A set 24.95

ACCESSORIES & DECALS



CLASSIC CHEVROLET PARTS COMPANY T-SHIRT

size Small	
TS-99-S each	14.95
size medium	
TS-99-M each	14.95
size large	
TS-99-L each	14.95
size X-large	
TS-99-XL each	14.95
XX-large	
TS-99-XXL each	18.95

FUZZY DICE!



3 IN. FUZZY DICE

Black w/ white dots	
B-17900-B pair	4.95
Blue w/ white dots	
B-17900-N pair	4.95
Red w/ white dots	
B-17900-R pair	4.95
White w/ black dots	
B-17900-W pair	4.95



PARK SAFE GARAGE PARKING SYSTEM

Positions your car in the same place every time using a motion sensor/light device. When you pull into the garage, the light is green. As you pull forward, the device will turn red indicating your car is in the exact place it needs to be. Comes complete with All components you need for easy installation.

All Chevrolet
M-100-PS each

149.95



1955-56 price list



1956 price list

CAR/TRUCK ACCESSORY PRICE LISTS

1939 Chevy/GMC Chevrolet Pickup	
DC-140-540 each	4.00
1940 Chevy/GMC Chevrolet Pickup	
DC-140-541 each	4.00
1941 Chevy/GMC Chevrolet Pickup	
DC-140-539 each	4.00
1947 Chevy/GMC Chevrolet Pickup	
DC-140-276 each	4.00
1949 Chevy/GMC Chevrolet Pickup	
DC-140-277 each	4.00
1950 Chevy/GMC Chevrolet Pickup	
DC-140-278 each	4.00
1952 Chevy/GMC Chevrolet Pickup	
DC-140-175 each	4.00
1954 Chevy/GMC Chevrolet Pickup	
DC-140-174 each	4.00
1955 Chevy/GMC Chevrolet Pickup	
DC-140-77 each	4.00
1955-56 Chevy/GMC Chevrolet Pickup	
DC-140-90 each	4.00
1956 Chevy/GMC Chevrolet Pickup	
DC-140-78 each	4.00
1957 Chevy/GMC Chevrolet Pickup	
DC-140-79 each	4.00
1960 Chevy/GMC Chevrolet Pickup	
DC-140-1709 each	4.00
1961 Chevy/GMC Chevrolet Pickup	
DC-140-171 each	4.00
1962 Chevy/GMC Chevrolet Pickup	
DC-140-172 each	4.00



1960 price sticker



1974-75 price sticker

WINDOW PRICE STICKER

1955-59	
DC-140-61 each	5.00
1960	
DC-140-658 each	5.00
1961-65	
DC-140-661 each	5.00
1966-67	
DC-140-86 each	5.00
1968	
DC-140-879 each	5.00
1969	
DC-140-711 each	5.00
1970-71	
DC-140-50 each	5.00
1972-73	
DC-140-139 each	5.00
1974-75	
DC-140-880 each	5.00
1976-78	
DC-140-374 each	5.00

Classic Chevrolet Parts Inc.

8713 S. I-35
 Oklahoma City, OK 73149

Summer Store Hours:

Monday – Friday
 8 a.m. thru 6 p.m.

Saturday
 8 a.m. thru 12 p.m.

Winter Store Hours:

Monday – Friday
 8 a.m. thru 5 p.m.

Saturday
 8 a.m. thru 12 p.m.

(Central Standard Time)

Stop by our showroom!



AIR CLEANER & VALVE COVER DECALS



DC-100-115



DC-100-659

1937-46

Dry style air cleaner service instruction decal

DC-100-659 each 4.50

Oil bath air cleaner service instruction decal

DC-100-115 each 4.50



DC-115-833



DC-100-23

1947-53

Thriftmaster 216 valve cover decal

DC-115-833 each 4.50

Dry style air cleaner service instruction decal

DC-100-434 each 4.50

Oil bath air cleaner service instruction decal

DC-100-23 each 4.50



DC-100-23



DC-115-834

1954

Dry style air cleaner service instruction decal

DC-100-434 each 4.50

Oil bath air cleaner service instruction decal

DC-100-23 each 4.50

Thriftmaster 235 valve cover decal

DC-115-834 each 4.50



DC-115-304



DG-115-69



DC-100-23

1955

Thriftmaster 235 valve cover decal

DC-115-834 each 4.50

Workmaster V8 valve cover decal

DC-115-304 each 4.50

GMC valve cover decal

DG-115-69 each 4.50

6 cyl air cleaner service instruction decal

DC-100-20 each 4.50

V8-2V air cleaner service instruction decal

DC-100-21 each 4.50

V8-4V air cleaner service instruction decal

DC-100-22 each 4.50

Oil bath air cleaner service instruction decal

DC-100-23 each 4.50



DC-115-303



DC-115-376



DC-115-301



DC-115-304



DG-115-69

1956-58

Hi thrift six valve cover decal

DC-115-303 each 4.50

Thriftmaster special valve cover decal

DC-115-376 each 4.50

Thriftmaster economy valve cover decal

DC-115-301 each 4.50

Workmaster V8 valve cover decal

DC-115-304 each 4.50

GMC valve cover decal

DG-115-69 each 4.50

6 cyl air cleaner service instruction decal

DC-100-20 each 4.50

V8-2V air cleaner service instruction decal

DC-100-21 each 4.50

V8-4V air cleaner service instruction decal

DC-100-22 each 4.50



DC-115-303



DC-115-376



DC-115-301



DC-115-304



DG-115-69

1959-60

Hi thrift six valve cover decal

DC-115-303 each 4.50

Thriftmaster special valve cover decal

DC-115-376 each 4.50

Thriftmaster economy valve cover decal

DC-115-301 each 4.50

Workmaster V8 valve cover decal

DC-115-304 each 4.50

GMC valve cover decal

DG-115-69 each 4.50

6 cyl air cleaner service instruction decal

DC-100-20 each 4.50

V8-2V air cleaner service instruction decal

DC-100-21 each 4.50

V8-4V air cleaner service instruction decal

DC-100-22 each 4.50



DC-115-303



DC-115-376



DC-115-301

1961

Hi thrift six valve cover decal

DC-115-303 each 4.50

Thriftmaster special valve cover decal

DC-115-376 each 4.50

Thriftmaster economy valve cover decal

DC-115-301 each 4.50

Workmaster V8 valve cover decal

DC-115-304 each 4.50

Air cleaner service instruction decal

DC-100-48 each 4.50

We appreciate your business!

**Can't find it?
Call us -
we'll get it
for you!**



AIR CLEANER & VALVE COVER DECALS



DC-115-364



DC-115-569

1962

- Hi-torque 153 valve cover decal
DC-115-364 each 4.50
- Hi-torque 235 valve cover decal
DC-115-314 each 4.50
- Hi-torque 283 valve cover decal
DC-115-315 each 4.50
- Hi-torque 348 valve cover decal
DC-115-569 each 4.50
- Hi-torque 409 valve cover decal
DC-115-570 each 4.50
- Air cleaner service instruction decal
DC-100-48 each 4.50



DC-115-364



DC-115-399



DC-115-316



DC-115-569

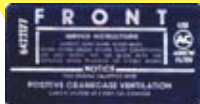

DC-100-189



DC-100-188

1963-65

- Hi-torque 153 valve cover decal
DC-115-364 each 4.50
- Hi-torque 230 valve cover decal
DC-115-399 each 4.50
- Hi-torque 283 valve cover decal
DC-115-315 each 4.50
- Hi-torque 292 valve cover decal
DC-115-365 each 4.50
- Hi-torque 327 valve cover decal
DC-115-316 each 4.50
- Hi-torque 348 valve cover decal
DC-115-569 each 4.50
- Hi-torque 409 valve cover decal
DC-115-570 each 4.50
- V8-2V air cleaner service instruction decal
DC-100-189 each 4.50
- V8-4V air cleaner service instruction decal
DC-100-188 each 4.50
- Oil bath air cleaner service instruction decal
DC-100-501 each 4.50



DC-115-316



DC-100-189



DC-100-188

1966

- Hi-torque 250 valve cover decal
DC-115-400 each 4.50
- Hi-torque 292 valve cover decal
DC-115-365 each 4.50
- Hi-torque 283 valve cover decal
DC-115-315 each 4.50
- Hi-torque 327 valve cover decal
DC-115-316 each 4.50
- V8-2V air cleaner service instruction decal
DC-100-189 each 4.50
- V8-4V air cleaner service instruction decal
DC-100-188 each 4.50
- 283 heavy duty air cleaner service decal
DC-100-1270 each 4.50
- 327-4V air cleaner service instruction decal
DC-100-995 each 4.50



DC-115-954



DC-100-189



DC-100-188

1967

- "250" valve cover decal
DC-115-954 each 4.50
- "292" valve cover decal
DC-115-959 each 4.50
- "283" valve cover decal
DC-115-955 each 4.50
- "327" valve cover decal
DC-115-957 each 4.50
- 250-1V air cleaner service instruction decal
DC-100-1069 each 4.50
- V8-2V air cleaner service instruction decal
DC-100-189 each 4.50
- V8-4V air cleaner service instruction decal
DC-100-188 each 4.50

**CLASSIC CHEVROLET
PARTS KNOWS
TRUCKS!**



DC-115-956



DC-115-954

1968

- "250" valve cover decal
DC-115-954 each 4.50
- "292" valve cover decal
DC-115-959 each 4.50
- "307" valve cover decal
DC-115-958 each 4.50
- "327" valve cover decal
DC-115-957 each 4.50
- "396" valve cover decal
DC-115-956 each 4.50
- 250-1V air cleaner service instruction decal
DC-100-1069 each 4.50
- 307-2V air cleaner service instruction decal
DC-100-1059 each 4.50
- Keep Your GM All GM air cleaner decal
DC-100-391 each 4.50



DC-115-954



DC-115-956



DC-115-237



DC-100-391

1969

- "250" valve cover decal
DC-115-954 each 4.50
- "292" valve cover decal
DC-115-959 each 4.50
- "307" valve cover decal
DC-115-958 each 4.50
- "350" valve cover decal
DC-115-983 each 4.50
- "396" valve cover decal
DC-115-956 each 4.50
- GMC Invader 350 valve cover decal
DC-115-236 each 5.00
- GMC Invader 427 valve cover decal
DC-115-237 each 5.00
- Keep Your GM All GM air cleaner decal
DC-100-391 each 4.50

**We appreciate your
business!**

www.classicchevroletparts.com



ACCESSORIES & DECALS

AIR CLEANER & VALVE COVER DECALS



DC-115-954



DC-115-956



DC-115-237



DC-100-391

1970

- "250" valve cover decal
- DC-115-954 each** 4.50
- "307" valve cover decal
- DC-115-958 each** 4.50
- "350" valve cover decal
- DC-115-983 each** 4.50
- "396" valve cover decal
- DC-115-956 each** 4.50
- GMC Invader 350 valve cover decal
- DC-115-236 each** 5.00
- GMC Invader 400 valve cover decal
- DC-115-931 each** 5.00
- GMC Invader 427 valve cover decal
- DC-115-237 each** 5.00
- GMC Invader 454 valve cover decal
- DC-115-238 each** 5.00
- Keep Your GM All GM air cleaner decal
- DC-100-391 each** 4.50

1971

- "250" valve cover decal
- DC-115-954 each** 4.50
- "307" valve cover decal
- DC-115-958 each** 4.50
- "350" valve cover decal
- DC-115-983 each** 4.50
- "396" valve cover decal
- DC-115-956 each** 4.50
- GMC Invader 350 valve cover decal
- DC-115-236 each** 5.00
- GMC Invader 400 valve cover decal
- DC-100-931 each** 5.00
- GMC Invader 427 valve cover decal
- DC-115-237 each** 4.50
- GMC Invader 454 valve cover decal
- DC-115-238 each** 4.50
- Keep Your GM All GM air cleaner decal
- DC-100-391 each** 4.50

DC-115-96



1972

- Tonawanda #1 valve cover decal
- DC-115-96 each** 4.50
- Keep Your GM All GM air cleaner decal
- DC-100-867 each** 4.50

GOT DECALS?

DC-100-867



1973-75

- Keep Your GM All GM air cleaner decal
- DC-100-867 each** 4.50
- Special parts notice valve cover
- DC-115-929 each** 4.50

1979

- 350-4V AT Keep Your GM All GM decal
- DC-125-1421 each** 4.50

ENGINE COMPARTMENT DECALS

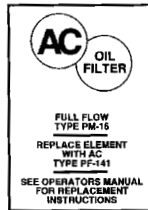

1937-54

- Oil filter decal
- DC-125-116 each** 5.00



1937-46

- "AC" oil filter canister decal
- DC-115-246 each** 5.00

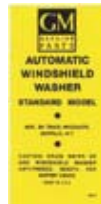

1940-50

- Trico windshield washer bracket decal
- DC-125-894 each** 5.00



ENGINE COMPARTMENT DECALS



1940-60

- GM windshield washer bottle bracket
- DC-125-645 each** 4.50

1941-49

- Trico windshield washer lid decal
- DC-125-244 each** 5.00



1947-63

- Generator warning
- DC-125-53 each** 4.50



1949-54

- Radiator condenser overflow tank decal
- DC-125-925 each** 5.00



1949-60

- Methanol anti-freeze tag
- DC-125-862 each** 5.00

1952-70

- Aluminum service/lube sticker
- DC-125-62 each** 4.50

1953-69

- Freon charge a/c comp tag
- DC-125-1374 each** 4.50

1954-69

- Hydrumatic transmission oil decal
- DC-125-120 each** 5.00

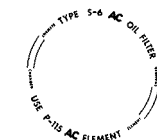

1955

- Oil filter lid decal
- DC-125-30 each** 5.00



1955-57

- Oil filter cap decal
- DC-125-29 each** 4.50



ENGINE COMPARTMENT DECALS



DC-125-106



DC-125-107

1955-60

Hydramatic transmission oil decal

DG-125-070 each 5.00

GM manual windshield washer lid

DC-125-107 each 4.50

GM automatic windshield washer lid decal

DC-125-106 each 4.50



1956-57

Oil filter canister decal

DC-125-31 each 5.00



1958-64

Oil filter canister decal

DC-125-205 each 4.50

1958-63

Oil filler cap decal

DC-125-338 each 4.00



1959-60

Windshield washer adjustment tag

DC-125-218 each 4.00



1960-75

Dealer installed anti-freeze decal

DC-125-462 each 4.00



1961-64

Caution cooling system decal

DC-125-901 each 4.50



DC-125-647



DC-125-101



DC-125-204

1961-67

GM Kleerview windshield washer bottle decal

DC-125-647 each 4.50

GM Optikleem windshield washer bottle decal

DC-125-204 each 4.00

Windshield washer bottle cap

DC-125-101 each 4.50

1962-63

Caution battery decal

DC-125-890 each 4.50

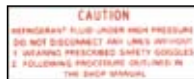

DC-125-49



DC-125-392

1963-65

Frigidaire a/c compressor warning

DC-125-49 each 4.50

Frigidaire a/c compressor decal

DC-125-392 each 5.50



1964-66

Caution battery decal

DC-125-322 each 4.50



DC-125-210



DC-125-1269

1964-67

Oil filler cap decal

DC-125-210 each 4.00

Delcotron alternator decal

DC-125-1269 each 5.00



1965

Harrison a/c evaporator box decal

DC-125-546 each 5.00



DC-125-741



DC-125-599



DC-125-933



DC-125-547

1966

Frigidaire a/c compressor decal - red

DC-125-599 each 5.50

Frigidaire a/c compressor decal - green, model # 6550113

DC-125-933 each 5.50

Frigidaire a/c compressor decal - green, model # 6550133

DC-125-741 each 5.50

Harrison a/c evaporator box decal

DC-125-547 each 5.00

1966-67

"Canada" oil change decal

DC-125-982 each 5.00



DC-125-548



DC-125-733



DC-125-601

1967

Harrison a/c evaporator box decal

DC-125-548 each 5.00

Frigidaire a/c compressor decal - red

DC-125-601 each 5.50

Frigidaire a/c compressor decal - orange

DC-125-733 each 5.50



1967-68

Frigidaire a/c compressor decal - green

DC-125-740 each 5.50



DC-125-549



DC-125-605

1968

Harrison a/c evaporator box decal

DC-125-549 each 5.00

Frigidaire a/c compressor decal - red

DC-125-605 each 5.50



ACCESSORIES & DECALS

ENGINE COMPARTMENT DECALS

1968-69

"Canada" oil change decal
DC-125-414 each 5.00



1968-73

GM replacement windshield washer bottle
DC-125-648 each 4.50



DC-125-550



DC-125-606



DC-125-774

1969

Harrison a/c evaporator box decal
DC-125-550 each 5.00
Frigidaire a/c compressor decal - red, model # 5910745
DC-125-606 each 5.50
Frigidaire a/c compressor decal - red, model # 5910688
DC-125-774 each 5.50



1969-71

Frigidaire a/c compressor decal - green
DC-125-738 each 5.50



DC-125-551



DC-125-607

1970

Frigidaire a/c compressor decal - red
DC-125-607 each 5.50
Harrison a/c evaporator box decal
DC-125-551 each 5.00

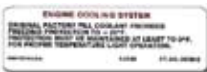

DC-125-242



DC-125-972

1970-71

"Canada" oil change decal
DC-125-972 each 5.00
Caution cooling system decal
DC-125-242 each 4.50



DC-125-552



DC-125-608

1971
Frigidaire a/c compressor decal - red
DC-125-608 each 5.50
Harrison a/c evaporator box decal
DC-125-552 each 5.00



DC-125-553



DC-125-609

1972
Frigidaire a/c compressor decal - red
DC-125-609 each 5.50
Harrison a/c evaporator box decal
DC-125-553 each 5.00

1972-74

GM replacement windshield washer bottle
DC-125-1282 each 4.50



1973
Harrison a/c evaporator box decal
DC-125-554 each 5.00
Caution cooling system decal
DC-125-134 each 4.50



1974-75
Cooling system decal
DC-125-423 each 4.50
Harrison a/c evaporator box decal
DC-125-1253 each 5.00

1974-76

Frigidaire a/c compressor decal - green
DC-125-739 each 5.50

1974-78

Warning coolant only decal
DC-125-459 each 4.50

1975-76

New refrigerant control system decal
DC-125-1265 each 5.00

1976

Harrison a/c evaporator box decal
DC-125-557 each 5.00



1977
Harrison a/c evaporator box decal
DC-125-941 each 6.00



1978
Delco a/c compressor decal
DC-125-980 each 6.00
Harrison a/c evaporator box decal
DC-125-1060 each 6.00



1978-82
Coolant notice decal
DC-125-470 each 4.50



1979-80
Caution fan decal
DC-125-471 each 4.50



1979
Delco a/c compressor decal
DC-125-1011 each 6.00
Delco a/c compressor decal
DC-125-1312 each 6.00
Harrison a/c evaporator box decal
DC-125-1066 each 6.00



1980
Delco a/c compressor decal
DC-125-1065 each 6.00
Harrison a/c evaporator box decal
DC-125-944 each 6.00

We accept
Visa,
Master Card,
and
Discover
Order Now!



EMISSION DECALS

1969



- 230-250-292 AT/MT emission decal
DC-130-1154 each 5.00
 350 AT/MT
DC-130-1204 each 5.00
 366 AT/MT 427 MT
DC-130-1213 each 5.00
 307-396-350/240 HP AT/MT
DC-130-669 each 5.00
 GMC 305 V6 MT
DC-130-1209 each 5.00
 GMC 305 V6 MT
DC-130-1182 each 5.00
 Chevy big truck 6 cyl
DC-130-1197 each 5.00
 307 AT/MT
DC-130-1173 each 5.00

1970



- 250-155 AT/MT emission decal
DC-130-372 each 5.00
 292-170 HP AT/MT
DC-130-1118 each 5.00
 350-255 HP AT/MT
DC-130-380 each 5.00
 402-310 HP AT/MT
DC-130-1234 each 5.00

1971



- 250-1V AT/MT emission decal
DC-130-1222 each 5.00
 Chevy truck 250 AT/MT
DC-130-1371 each 5.00
 Chevy truck 292 AT/MT
DC-130-1371 each 5.00
 Chevy truck 307 AT/MT
DC-130-1371 each 5.00
 292-165 AT/MT
DC-130-1172 each 5.00
 307-200 AT/MT
DC-130-856 each 5.00
 350-4V AT/MT
DC-130-422 each 5.00
 400-4V AT
DC-130-1194 each 5.00

1972

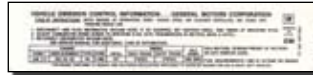

- 250-1V AT/MT emission decal
DC-130-1156 each 5.00
 292-1V AT/MT
DC-130-1186 each 5.00
 307-2V AT/MT
DC-130-1143 each 5.00
 350-4V AT/MT
DC-130-908 each 5.00
 402-4V AT/MT
DC-130-1188 each 5.00

1973

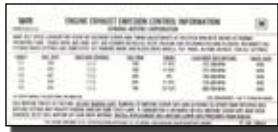

- 250-292-307-350-454 AT/MT emission decal
DC-130-1183 each 5.00

1974



DC-130-1017



DC-130-828

- 250-1V AT/MT emission decal
DC-130-1198 each 6.00
 250-1V MT
DC-130-1187 each 6.00
 250-1V AT/MT
DC-130-1017 each 6.00
 250-292-350-454
DC-130-1117 each 6.00
 350-2V AT/MT
DC-130-828 each 6.00
 350-4V AT/MT Suburban
DC-130-1152 each 6.00
 454-4V AT/MT
DC-130-451 each 6.00
 454-4V AT/MT Suburban
DC-130-1149 each 6.00

1976



- 262-305-2V AT emission decal
DC-130-813 each 6.00



DC-130-1061



DC-130-1027

1978

- 250-292-305-350-400-454 emission decal
DC-130-1061 each 6.00
 454 emission control info
DC-130-1027 each 6.00

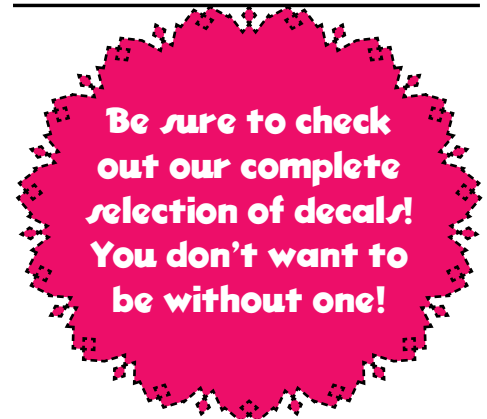

SAVE ON SHIPPING!
FREE DELIVERY TO ANY SWAP MEET WE ATTEND. JUST ASK FOR DETAILS!



check us out at
www.classicchevroletparts.com



ACCESSORIES & DECALS

INTERIOR DECALS



1934-52
Owners manual envelope
DC-140-91 each 4.50



1936-54
Glove box key decal
DC-140-247 each 3.00



1937-54
Engine break in instruction tag
DC-140-863 each 4.50
GMC truck battery notice card
DG-140-001 each 4.00
Battery warranty certificate
DC-140-683 each 4.00

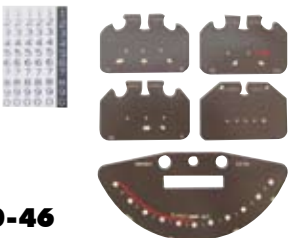

1940-46
Chevy truck speedometer decal set
DC-140-928 each 11.50



1946-60
Casco lighter instruction tag
DC-140-95 each 4.00

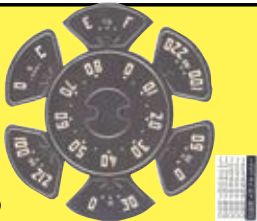

1947-49
Chevy truck speedometer decal set
DC-140-618 each 11.50

1947-53
GMC truck speedometer decal set
DG-140-75 each 11.50



1949-54
Recirculating heater decal
DC-140-776 each 5.00

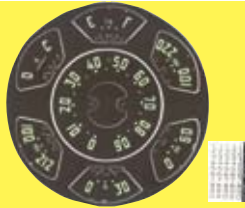

1950-53
Chevy truck speedometer decal set
DC-140-530 each 11.50



1950-70
Dealer aluminum service tag
DC-140-62 each 4.50



1953-57
Engine break in card
DC-140-59 each 4.00

1953-59
Air flow heater decal
DC-140-806 each 5.00



1953-62
Owners manual envelope
DC-140-135 each 4.50



1954
AT sun visor starting instruction sleeve
DC-140-712 each 5.00



1954-55
1 Series speedometer decal set
DC-140-835 each 11.50

1954-59
Hydramatic oil instruction decal
DC-140-1120 each 4.00



1955
Delivered new vehicle price list
DC-140-312 each 4.00



1955-57
Radio antenna adjustment decal
DC-140-88 each 4.00



1955-59
AT sun visor starting instruction sleeve
DC-140-713 each 5.00
Recirculating heater decal
DC-140-805 each 5.00
Speedometer decal set
DC-140-836 each 11.50

1955-62
Battery warranty certificate
DC-130-82 each 4.00

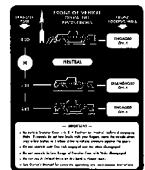

1957-59
Chevy/GMC 4-Wheel shift pattern decal
DC-140-808 each 5.00

1959-66
Car and truck emergency flasher switch tag
DC-140-1375 each 6.00

1961-62
Mirror instruction tag
DC-140-1030 each 5.00

ACCESSORIES & DECALS



INTERIOR DECALS



1961-64
Battery warranty certificate
DC-140-694 each 4.00



1962-65
Air conditioned window decal
DC-140-234 each 4.50

1962-67
Chevy/GMC 4-wheel shift pattern decal
DC-140-921 each 5.00
Chevy/GMC 4-wheel DANA Spicer instruction decal
DC-140-922 each 5.00



1963
Seat belt instruction card
DC-140-187 each 4.00



1963-66 This graphic is printed on the bag
Owners manual plastic bag
DC-140-801 each 6.00



1964-66
Dealers record/maintenance folder
DC-140-35 each 6.50



1964-67
Seat belt instruction card
DC-140-305 each 4.00



1965-68
Delco battery owners certificate
DC-140-695 each 4.00



1966-67
Air conditioned window decal
DC-140-235 each 4.50
Window price sticker
DC-140-86 each 5.00
AM/FM Stereo adapter operator instructions
DC-140-324 each 4.50



These graphics are printed on the bag

1967-68
Owners manual plastic bag
DC-140-802 each 6.00



1967-72
Service parts identification decal
DC-140-617 each 6.50

1969-70
Blazer 4-wheel drive operator instructions
DC-140-766 each 5.00
Suburban AT 4-wheel shift pattern
DC-140-767 each 5.00
Blazer AT 4-wheel shift pattern
DC-140-768 each 5.00
Blazer MT 4-wheel glove box warning
DC-140-769 each 5.00
Suburban AT 4-wheel Spicer hub lock decal
DC-140-770 each 5.00



These graphics are printed on the bag

1969-72
Owners manual plastic bag
DC-140-803 each 6.00



1971-74
Air shock instruction decal
DC-140-662 each 4.00

1973-82
Service parts identification decal
DC-140-692 each 6.50



1975-78
Air shock instruction decal
DC-140-460 each 4.00

JACK INSTRUCTION DECALS

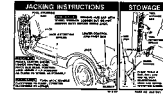

1955-59
Chevy/GMC jack stowage
DC-150-285 each 4.50

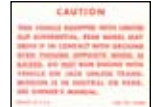

1957-63
Positraction warning decal
DC-150-43 each 4.00

1960-63
Chevy/GMC jack stowage
DC-150-994 each 5.00



1964-70
Positraction warning decal
DC-150-239 each 4.00



1968-72
Chevy/GMC jack instruction
DC-150-428 each 4.50



1971-73
Canada limited slip decal
DC-150-730 each 5.00



1971-78
Positraction warning decal
DC-150-321 each 4.00

1973
Chevy/GMC jack instruction
DC-150-670 each 4.50



1973-79
Chevy/GMC Jack base decal
DC-150-693 each 4.00



1974-77
Chevy/GMC jack instruction
DC-150-820 each 4.50

1976-77
Chevy/GMC jack instruction
DC-150-1286 each 4.50

1977-78
Suburban 4-wheel drive jack instruction
DC-150-1266 each 4.50



1978-79
Chevy/GMC jack instruction
DC-150-827 each 5.00



ACCESSORIES & DECALS

EXTERIOR DECALS

CHEVROLET

1947-53 "CHEVROLET" TAILGATE LETTERS

Red	
DC-160-743 each	11.50
White	
DC-160-744 each	11.50
Black	
DC-160-745 each	11.50



1947-54 "GMC" TAILGATE LETTERS

Red	
DG-160-79 each	9.50
White	
DG-160-77 each	9.50
Black	
DG-160-78 each	9.50
Chrome	
DG-160-76 each	9.50

CHEVROLET

1954-80 "CHEVROLET" STEPSIDE TAILGATE LETTERS

Red	
DC-160-746 each	11.50
White	
DC-160-747 each	11.50
Black	
DC-160-748 each	11.50
Chrome	
DC-160-755 each	11.50

CHEVROLET

1958-66 "CHEVROLET" FLEETSIDE TAILGATE LETTERS

Red	
DC-160-749 each	11.50
White	
DC-160-750 each	11.50
Black	
DC-160-751 each	11.50
Chrome	
DC-160-758 each	11.50

We appreciate your business!

GMC

1967-87 "GMC" TAILGATE LETTERS

White	
DG-160-2 each	9.50
Black	
DG-160-3 each	9.50
Red	
DG-160-4 each	9.50

CHEVROLET

1967-72 "CHEVROLET" FLEETSIDE TAILGATE LETTERS

Red	
DC-160-752 each	11.50
White	
DC-160-753 each	11.50
Black	
DC-160-754 each	11.50
Chrome	
DC-160-757 each	11.50



1970-72

Chevy/GMC disc brake tailgate	
DC-160-532 each	5.00



1975

"Beau James" bed side decal	
DG-160-5 pair	69.95
"Gentlemen Jim" bed side decal	
DG-160-6 pair	59.95

Classic Chevrolet Parts has been serving your car and truck needs for 12 years and counting! We appreciate our customers!

MISC. DECALS



CHEVY BOWTIE STICKER

Blue on white, 7 inches.	
DC-180-369 each	5.00
Blue on clear, 7 inches.	
DC-180-1316 each	5.00
Blue on white, 13 inches.	
DC-180-368 each	6.00
Blue on clear, 13 inches.	
DC-180-1317 each	6.00



CHEVROLET SPECIAL PARTS WINDOW DECAL

3 inches.	
DC-180-602 each	5.00
5 inches.	
DC-180-603 each	6.00
8 inches.	
DC-180-604 each	6.50



2" WHEEL CENTER DECALS

Chevy bowtie (Aftermarket)	
DC-180-1377 each	6.50
Chevrolet script (Aftermarket)	
DC-180-1378 each	6.50



7" CHEVY BOWTIE

White	
DC-180-1382 each	6.50
Black	
DC-180-1383 each	6.50
Gold	
DC-180-1384 each	6.50
Red	
DC-180-1385 each	6.50
Blue	
DC-180-1386 each	6.50
Silver	
DC-180-1387 each	6.50

ENGINE PARTS & GRILLS

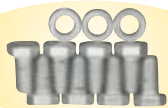

HOOD HINGE BOLT KIT

1932-80 All Chevy Hood Hinges
CK-0012-AS set of 16 24.95



STEEL VALVE COVER MOUNTING BOLT KIT

1932-80 Chevrolet Big Block
CK-0017-BS set of 14 24.95
 1932-80 Chevrolet Small Block
CK-0017-DS set of 8 14.95

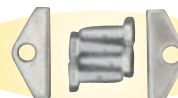

VALVE COVER HOLD DOWN CLIP AND BOLT KIT

1932-80 Chevrolet Big or Small Block
CK-0017-FS set of 8 21.95



ENGINE BOLT KIT

Stainless steel. Includes fasteners for intake manifold, water neck, timing cover, fuel pump, oil pan, dist. hold down, headers, water pump, valve covers.
 1932-80 Big Block Chevy
CK-0100-BB kit 39.95
 1932-80 All Small Block
CK-0100-SB kit 29.95



STARTER BOLT KIT W/LOCK WASHERS

Stainless steel hex head.
 All big block Chevys
CK-0111-BS kit 3.95
 All Small block Chevys
CK-0111-SS kit 3.95



BELL HOUSING BOLT KIT W/LOCK WASHERS

Stainless steel hex head. All big block Chevys.
CK-0113-BB kit 3.95
 All Small block Chevys
CK-0113-SB kit 3.95



1956-62

FRONT MOTOR MOUNT

Requires 4.
 1934-53 (194)
 1941-53 (216)
 1948-55 (235)
 1958-59 (348)
P3459-0027-A each 7.95
 1955-57 Chevrolet Pickup 283
P5557-0027-A each 2.95
 1955-57 Chevrolet Pickup 283
P5557-0027-B each 2.95
 1956-62 (235)
 1960-62 (194, 261 & 283 with Powerglide)
 Fits either left or right
P5662-0027-A each 11.95
 1963-69 (194, 230)
 1963-67 (283) manual trans or powerglide
 1963-72 (292)
 1963-72 GMC ser. 1500-3500
 1964-65 GMC ser. 15 (153)
 1965-68 (327)
 1966-72 heavy duty 250
 1966-72 K10-30 (250)
 1968-72 K10-30 (307)
 1968-72 (307)
 Fits either side
P6372-0027-A each 12.95

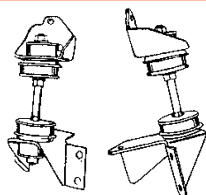

V8 FRONT MOTOR MOUNT KIT

1955-59 Chevrolet Pickup V8
P5559-0027-K kit 139.95

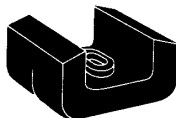

UPPER ENGINE MOUNT

Fits either side. Requires 2.
 1955-59 (316)
 1955-67 (265)
 1957-67 (283)
 1963-69 (194, 230)
 1963-72 (292)
 1965-68 (327)
 1966-68 10/30 (250)
 1966-72 (250)
 1968-70 (396)
 1968-72 (307)
P5772-0027-A each 9.95
 1958-65 Chevrolet Pickup (348)
P5870-0027-A each 12.95



LOWER MOTOR MOUNT

Requires 2.
 1958-65 Chevrolet Pickup (348)
P5870-0027-B each 6.95
 1955-67 (265)
 1957-67 (283 with MT)
 1963-69 (230 with MT)
 1963-69 (194)
 1963-72 (292 with MT)
 1965-68 (327 with MT)
 1966-72 (K10/30 (307 - 4WD)
 1968-72 (K10/30 (307 - with MT)
 1973-84 (K10/30 (292, 350 - 4WD)
 1975-84 (K10/30 (400 - 4WD)
P6372-0027-B each 4.95



FRONT MOTOR MOUNT PLATE

1947-55 (6 cyl. - 1st Series)
P4755-0029-PL each 9.95



More Valve Covers in the Street Rod section!

CHROME PLATED STEEL BIG BLOCK (396-454) VALVE COVERS

All big block w/out power brakes
 Stock height with baffles, OEM style- no drippers.
B-0386-OB pair 59.95
 All big block w/power brakes
 Stock height w/ baffles. OEM style- no drippers.
B-0386-OPB pair 59.95



VALVE COVER ACORN NUTS

For securing cover to head. Non-polished stainless steel.
 1934-53 Chevy (216)
 1939-59 GMC
P-0386-AN each 4.95



VALVE STEM OIL SEALS

1960-72 Chevrolet Pickup Small block - V8
P-0386-OS set of 16 14.95



ENGINE PARTS & GRILLS



VALVE COVER STUD TOP SEALS

1934-53 Chevy 216
1939-59 GMC
P-0386-TS each 2.95



VALVE COVER GROMMETS

1947-54 Chevrolet Pickup
P4754-0386-G pair 2.95



BIG BLOCK VALVE COVER MOUNTING KIT

Correct "TR" bolts and retainers.
1969-87 All
A6572-0386-HK kit 21.95



CHECK THIS OUT!

FLYWHEEL TRANSMISSION CONVERTER UNDERPAN

1973 All with TH400 (307)
1973-74 All
1973-74 All with TH400 (350,454)
P7374-0679-A each 46.95
1973-74 All
P7374-0679-B each 36.95
1973 All
1973 All with TH350, 350
1974 All Blazer, Jimmy with TH350, 4BC, 350
1974 All Blazer, Jimmy with TH350, 2BC, 350
1975-78 All Blazer, Jimmy with AT, 250
1975-78 All Blazer, Jimmy with AT, 350
1975-78 All with TH350 (454)
1979-80 All 6 cyl.
1979-81 All with AT 305, 350, 454
P7381-0679-A each 39.95



CHROME TIMING TAB

Chevrolet 396 - 454
P-0724-396454TB each 2.95



LINKAGE-TO-OFFSET ROD

Attaches to pedal arm.
1941-59 Chevrolet Pickup
P4159-0787-A each 7.95



CLUTCH OFFSET ROD

Attaches to clutch fork.
1947-59 Chevrolet Pickup
P4759-0787-A each 16.95



CLUTCH FORK BALL STUD

Threads into bell housing as original.
1968-59 Chevrolet Pickup 6 cyl only
P3859-0796-A each 14.95



CLUTCH FORK BOOT

1960-72
1960-72 Chevrolet Pickup
P6072-0797-A each 14.95
1973 All Blazer, Jimmy (exc. Prop. Shaft Park Brake - 250)
1974-78 All Blazer, Jimmy (exc. Prop. Shaft Park Brake - 250)
1977-78 All Blazer, Jimmy 305
1973 All Blazer, Jimmy (exc. Prop. Shaft Park Brake - 350)
1974-78 All Blazer, Jimmy (exc. Prop. Shaft Park Brake)
1973-78 All 454
1973 100/300, Blazer, Jimmy (exc. 11,000 lb. axle - 307)
1979-84 All
P7384-0797-BT each 7.95



STEERING COLUMN, CLUTCH & BRAKE PEDAL ROD SEALS

1939-46 Chevrolet Pickup
P3946-0829-A set 7.95



BRAKE & CLUTCH PEDAL FELT FLOOR SEALS

1947-51 Chevrolet Pickup
P4751-0829-A pair 4.95
1952-55 Chevrolet Pickup
P5255-0829-A pair 4.95
1955-59 Chevrolet Pickup
P5559-0829-A set 4.95



CLUTCH ARM STOP BUMPER

1947-59 Chevrolet Pickup
P4754-0829-A each 1.95



CLUTCH PEDAL PULL BACK SPRING

1932-40 Chevrolet Pickup
P3240-0844-CS each 9.95
1947-59 Chevrolet Pickup
P4759-0844-CS each 9.95



CLUTCH RELEASE SHAFT

Z-bar.
1967-72 Chevrolet Pickup
P6772-0852-A each 39.95



STAINLESS STEEL HOOD HINGE BOLT KITS

1955-57 Chevrolet Pickup
Hex head. Does both hinges.
P5557-1003-H kit 7.95
1958-59 Chevrolet Pickup
Indented hex head (original).
P5859-1003-I kit 10.95
1960-66 Chevrolet Pickup
Indented hex head (original). Does both hinges.
P6066-1003-I kit 10.95
1967-72 Chevrolet Pickup
Indented hex head (original). Does both hinges.
P6772-1003-I kit 16.95
1973-80 Chevy
Indented hex head (original). Does both hinges.
P7380-1003-I kit 19.95

CAN'T FIND WHAT YOU NEED?

JUST GIVE US A CALL!



WATER PUMPS

1941-53 Chevy pickup

New USA made water pump for 216 cu.in.

PU4153-1069-A each 119.95

1953-55 (6 cyl 1st Series in 1955)
Complete with mounting gasket. 3/8" wide pulley mounted on the pump. Will not fit GMC!

PU5355-1069-A each 99.95

1955-62 (235)

1963 (235 - 4WD)

Complete with mounting gasket.

PU5563-1069-A each 69.95

1955-63 (265, 283, 307, 327)

1964-67 (265, 283, 327)

1968-71 (283, 307, 327, 350)

1972 (10 & 20 series with 283, 307, 327, 350)

Complete with gasket.

PU5572-1069-A each 89.95

1963-64 (292)

Complete with mounting gasket.

PU6364-1069-A each 79.95

1966-72 All

1973-74 (250)

Complete with mounting gasket.

PU6374-1069-A each 61.95

1965-74 (292)

Complete with mounting gasket.

PU6574-1069-A each 69.95

1968-70 (396)

1971-72 (400, 402)

Complete with mounting gasket.

PU6872-1069-A each 179.95



WATER PUMP TO BLOCK GASKET

1955-72 All

13/32" id (cork)

P5572-1079-A each 1.95

1963-67 (194)

1963-69 (230)

1963-84 (292)

1966-81 (250)

P6381-1079-A each 1.95

1966-90 (366)

1968-70 (396)

1968-73 (427)

1971-72 (400)

1971-72 (402, big block)

1971-79 (454)

2 required

F6776-1079-AS each 1.95

1957-67 (283)

1962-69 (327)

1968-73 (307)

1969-80 (350)

1975-80 (400, Small block)

1976-86 (305)

2 required

F6781-1079-AS each 1.95

1968-72 (396, 400)

1 7/16" id x two 13/32" holes at ends

P6872-1079-A each 1.95



1950-53



1967-72

TEMPERATURE GAUGE ASSEMBLY

1947-49 Chevy pickup

12 volt with red needle, complete with line. Will work for V8 or 6 cyl.

P4749-1148-12 each. 59.95 **NEW!**

1947-49 Chevy pickup

6 volt with red needle, complete with line. **NEW!**

P4749-1148-6 each. 59.95

1950-53 Chevy pickup

12 volt, complete with line, fits 6 or 8 cyl. **NEW!**

P5053-1148-12 each. 59.95

1950-53 Chevy pickup

6 volt, w/ white needle, complete with line. **NEW!**

P5053-1148-6 each. 59.95

1955-59 Chevy pickup

Electric.

P5559-1148-A each 79.95

1967-72 Chevy pickup

Dash unit. Exact reproduction.

P6772-1148-A each 39.95



WATER OUTLET

1966 (283 w/air injection reactor)

1967 (327 without A/C)

1967-69 (283, 307, 327, 350, without A/C)

1970-72 (8 cyl.)

PU6672-1153-A each 29.95

1967-72 (230, 250, 292)

1973-77 (6 cyl)

1978 (6 cyl - exc 250 with integral head)

PU7277-1153-A each 66.95

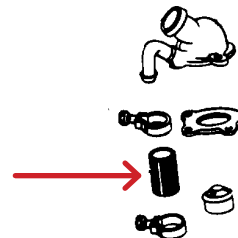

RADIATOR INLET HOSE

1 1/2" id

1958-62 (8 cyl)

1963 (4WD - 8 cyl)

P5863-1159-A each 29.95



TOWER TYPE RADIATOR HOSE CLAMP

Set of 8 tower hose clamps, includes 2 upper & 2 lower radiator hose clamps & 2 each of heater hose clamps.

1955-72 Chevrolet Pickup

B-1166-set set 26.95



We supply gift certificates in any amount, for any occasion!

Some of our items are proudly made in the USA by Dale's Manufacturing out of OKC!

We accept Visa, Master Card, and Discover.



ENGINE PARTS & GRILLS



1934-36



1967-77

RADIATOR CAP

1934-36 Chevrolet Pickup
Chrome and die cast.

P3436-1203-CH each 32.95

1937-52 Commercial & Utility

P3752-1203-A each 5.95

1953-54 (Ser. 10/30, Blazer & Suburban)

1955 Early Models Blazer & Suburban

P5355-1203-A each 5.95

1955-59 (2nd series)

1960-62 Ser. 10 thru 30

Pressure type cap w/ gasket

P5568-1203-A each 9.95

1963-64 Ser. 10 thru 30 (exc. D-D)

1964-65 Ser. 10 D-D 4 cyl

1965-69 Ser. 10 thru 30 (exc. D-D)

1970 Ser. 10-20, Blazer without A/C, 396 or D-D

Pressure type ac delco cap w/ gasket

P6370-1203-A each 11.95

1965-69 Ser. 10 thru 30 with A/C

1970 All with 396 or A/C

1970-72 Blazer All

ac delco w/gasket

P6572-1203-A each 19.95

1967-77 Ser. 10-30 with A/C

aftermarket/16lbs.

F6776-1203-A each 4.95

All-American Deals



These colors don't run!

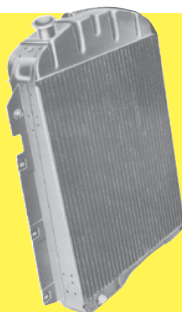

RADIATOR ASSEMBLY

1947-54 Chevy pickups

NEW! Use this high efficiency radiator when converting to a V8 engine. 4 row core.

P4754-1219-V8 each 429.95

1948-54 (Ser. 1/2 ton - 1 1/2 ton)

No air, normal duty, 2 row core

Must specify auto or manual transmission!

P4854-1219-A each 399.95

1948-54 (1-1/2 ton to 2 ton)

Standard, no air, normal duty, 2 row core

P4854-1219-B each 399.95

1955-59 (1/2 ton to 1 ton)

Standard, no air, normal duty, 2 row core

P5559-1219-A each 399.95

1955-59 (3/4 ton - 1 ton or ALL automatic transmissions)

Automatic, no air, normal duty, 2 row core

P5559-1219-B each 399.95

1960-62 (1/2 ton - 1 ton)

Standard, w/air, normal duty, 2 row core

P6062-1219-A each 399.95

1960-62 (3/4 ton - 1 ton or ALL automatic transmissions)

Automatic, no air, normal duty, 2 row core

P6062-1219-B each 399.95

1963-66 (230 6 cyl. only Chevy/GMC)

Automatic, no air, normal duty, 2 row core

P6366-1219-A each 399.95

1963-66 Ser. 1/2 ton - 3/4 ton 292 V8

1963-66 GMC V6 & V8

Automatic, w/air, normal duty, 2 row core

P6366-1219-B each 399.95

1966 (1/2 ton - 3/4 ton w/factory air (V8 only)

Automatic, w/air, normal duty, 2 row

P66-1219-A each 399.95

1967-70 (1/2 ton - 1 ton factory 4 row core)

Core size is 28-3/8 x 17 x 2-5/8

P6770-1219-A each 442.95

1967-72 (1/2 ton - 1 ton w/std. trans - 250 6 cyl 2 row core)

Standard, no air, normal duty

P6772-1219-A each 299.95

1967-72 (1/2 ton - 1 ton factory 3 row core)

Standard, no air, heavy duty

P6772-1219-B each 399.95

1971-72 (1/2 ton - 1 ton factory 4 row core)

Automatic, w/air, desert cooler

P7172-1219-A each 379.95



GMC RADIATOR

1948-54 (100/300)

Standard, no air, normal duty, 2 row

P4854-1219-GA each 399.95

1948-54 (300)

Standard, no air, normal duty, 2 row

P4854-1219-GB each 399.95

1955-59 (100 6 cyl)

Standard, no air, normal duty, 2 row

P5559-1219-GA each 399.95

1955-59 All

Standard, no air, normal duty, 2 row

P5559-1219-GB each 399.95

1960-62 (100)

Automatic, no air, normal duty, 2 row

P6062-1219-GA each 399.95

1960-62 (200)

Automatic, no air, normal duty, 2 row

P6062-1219-GB each 399.95

1963-66 V6 - V8

Top connection is in center - automatic or standard, w/ or w/out air, normal duty, 2 row

P6366-1219-GB each 399.95

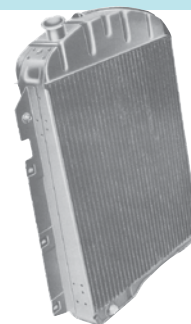

2 ROW CORE RADIATOR

1973 (5.7L, 350, V8, MT, with A/C - Max)

1973 (5.0L, 307, V8, MT, with A/C - Max)

1973 (4.8L, 292, L6, AT - Max)

1973-74 (4.1L, 250, L6, AT - Max)

1974-75, 76, 78 (5.7L, 350, V8, MT, w/ A/C - Max)

1974-78 (4.8L, 292, L6, MT, with A/C - Max)

1978 (5.0L, 305, V8, MT - Max)

1978 (4.1L, 250, L6, AT, with A/C - Max)

1978-79 (4.1L, 250, L6, AT, with A/C - Max)

1979 (4.8L, 292, L6, with A/C - Max)

Core: 28 1/4" x 17" x 1 1/4"

P7379-1219-B each 159.95

1973-74, 78, 79 (4.1L, 250, L6, MT - STD)

1973-77 (4.8L, 292, L6, MT - STD)

Core: 26 1/4" x 17" x 1 1/4"

P7379-1219-C each 189.95

1979 (4.1L, 250, L6, MT, with A/C - Max)

1980 (530L, 305, V8, MT)

1980 (4.1L, 250, L6, AT - Max)

1980 (5.7L, 350, V8, MT, with A/C - STD)

Core: 28 1/4" x 17" x 1 1/4"

P7980-1219-A each 249.95

1980 (4.1L, 250, L6, AT, with A/C - STD)

Core: 26 1/4" x 17" x 1 1/4"

P80-1219-F each 259.95

More radiators on the next page...



Radiators continued from previous page...



3 ROW CORE RADIATOR

1973-74 (4.8L, 292, L6, MT - Max)
1973-74 (4.1L, 250, L6, MT - Max)
Core: 26 1/4" x 17" x 1 7/8"

P7374-1219-A each 259.95

1973 (5.7L, 350, V8, MT, with A/C- Max)
Core: 28 1/4" x 17" x 1 7/8"

P7379-1219-A each 249.95

1973 (5.0L, 307, V8, AT)
1973-74, 76 & 77 (5.7L, 350, V8, AT)
1975 (5.7L, 350, V8, with A/T - AC - Max)
1977 (5.0L, 305, V8, AT)
1977 (5.0 L, 305, V8, with A/T)
Core: 28 1/4" x 17" x 1 7/8"

P7377-1219-A each 249.95

1973-74, 76 & 77 (7.4L, 454, V8, MT OR AT)
1977 (5.7L, 350, V8, AT with AC)
1978 (6.6L, 400, V8 with AC - Max)
1978 (7.4L, 454, V8 with AC - Max)
1979 (6.6L, 400, V8 with AC - Max)
1979 (7.4L, 454, V8 AT; MT, with AC - Max)
1980 (7.4L, 454, V8)
1980 (5.7L, 350, V8, AT - Max)
1980 (5.0L, 305, V8 A T- Max)
1980 (6.6L, 400, V8 - Max)
Core: 20 3/4" x 17" x 1 5/8"

P7380-1219-A each 259.95

1974-76 (6.5L, 400, V8)
1977-78 (5.7L, 350, V8 AT - STD)
1978 (7.4L, 454, V8 - STD)
1978 (5.0L, 305, V8, AT with AC - Max)
1978-79 (6.6L, 400, V8 - STD)
1979 (5.7L, 350, V8, AT)
1980 (5.7L, 350, V8, AT with AC)
1980 (6.6L, 400, V8 with AC - STD)
Core: 28 1/4" x 19" x 1 7/8"

P7480-1219-A each 259.95

1980 (5.7L, 350, V8, MT - Max)
Core: 28 1/4" x 17" x 1 7/8"

P80-1219-A each 299.95

1980 (5.7L, 350, V8, A/T - STD)
1980 (5.0L, 305, V8, A/T - STD)
Core: 28 1/4" x 17" x 1 5/8" no a/c

P80-1219-B each 259.95

1980 (4.1L, 250, L6, AT, w/AC - STD)
Core: 26 1/4" x 17" x 1 5/8"

P80-1219-D each 259.95

1980 (4.1L, 250, L6, AT - Max)
Core: 28 1/4" x 17" x 1 5/8"

P80-1219-E each 259.95

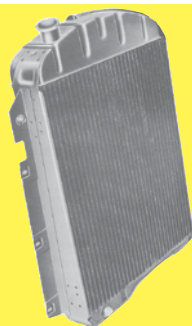

4 ROW CORE RADIATOR

Core: 28 1/4" x 17" x 2 1/2"
1977 (5.0L, 305, V8, MT - Max)
1977-79 (5.7L, 350, V8, MT - Max)

P7779-1219-A each 249.95



LOWER RADIATOR HOSE

1947-55 Chevrolet Pickup

P4755-1219-LA each 21.95

1947-54 GMC Chevrolet Pickup

1963 (292)

1963 (230 A/T)

1964-65 (194, 230 A/T)

1964-65 (292 w/o air or std. cooling)

1966 (194, 230, 250, 292)

P4766-1219-LA each 19.95

1955 Chevrolet Pickup

P55-1219-LA each 15.95

1955-59 Chevy

1960-62 (235, 261 A/T)

1963 (230 M/T)

1964-65 (194, 230 M/T)

P5565-1219-LA each 11.95

1958 GMC V8

P58-1219-LA each 17.95

1958-59 GMC Chevrolet Pickup

1971-74 (6 cyl)

P5859-1219-LA each 22.95

1958-59 Chevrolet Pickup

P5859-1219-LB each 19.95

1960-62 V6 - 305

P6062-1219-LA each 29.95

1960-63 V8 1st design in 1963

P6063-1219-LA each 21.95

1963-66 V6 - 305

P6366-1219-LA each 24.95

1963-66 V8 2nd design in 1963

P6366-1219-LB each 17.95

1967 V6 - 305, 351 without AC

1969 (305)

P6769-1219-LA each 29.95

1967 V8 - 2WD

1968 (307,327 - 2WD w/o air)

1969-70 (307,350, 2WD w/o air)

P6770-1219-LA each 24.95

1967 V8 - 4WD without air

1968-70 (307, 327, 350 - 4WD without air)

P6770-1219-LB each 22.95

Lower radiator hoses continued...



1967 (194, 230, 250, 292)

1968-69 (230, 250, 292)

1970-72 (250, 292)

P6772-1219-LA each 24.95

1967 V8 - 4WD with Air

1968 (307, 327 with Air)

1969 (307, 350 with Air)

1970 (307, 350 with Air)

1971-72 (307, 350 All)

P6772-1219-LB each 21.95

1968-70 (396)

1971-72 (400)

P6872-1219-LA each 29.95

check us out at
www.classicchevroletparts.com

Service with a



Classic Chevrolet Parts has been serving your car and truck needs for 12 years and counting! We appreciate our customers!



ENGINE PARTS & GRILLS



UPPER RADIATOR HOSE

- 1947-55 Chevrolet Pickup
- P4755-1219-UA each** 12.95
- 1955-63 Chevrolet V8
- P5563-1219-UA each** 15.95
- 1955-59 GMC 6 cyl
- 1960-62 (235, 261)
- 1963-65 (230)
- P5565-1219-UA each** 9.95
- 1956-57 GMC (V8 upper hose)
- 1958-59 Chevy (V8 M/T lower hose)
- P5659-1219-A each** 19.95
- 1956-59 Chevrolet Pickup
- P5659-1219-UA each** 14.95
- 1958-59 GMC V8
- P5859-1219-UA each** 16.95
- 1960-62 V6 - 305
- P6062-1219-UA each** 22.95
- 1960-62 (235, 261 with M/T)
- P6062-1219-UB each** 17.95
- 1963-64 (292 6 cyl)
- P6364-1219-UA each** 24.95
- 1963-66 V6 - 305
- P6366-1219-UA each** 21.95
- 1965-66 (292 6 cyl) **may need to cut length to fit**
- P6566-1219-UA each** 16.95
- 1966 (194, 230, 250 6 cyl)
- P66-1219-UA each** 19.95
- 1967 (283 2WD)
- P67-1219-UA each** 19.95
- 1967 (327 - 2WD)
- P67-1219-UB each** 21.95
- 1967-69 V6 - 305, 351 fits from motor to the pipe
- P6769-1219-UA each** 14.95
- 1967-69 V6 - 305, 351 fits from pipe to radiator
- P6769-1219-UB each** 16.95
- 1967 (194, 230, 250)
- 1967-68 (292 without A/C)
- 1968-69 (230, 250)
- 1970 (250)
- P6770-1219-UA each** 22.95
- 1967-69 (292 with A/C)
- 1971 (250, 292, 307, 350 2WD)
- 1972 (250)
- 1972 (307, 350 2WD)
- P6772-1219-UA each** 19.95
- 1968 (307, 327 with 2WD)
- 1968-70 (396)
- 1969 (307, 350 with 2WD)
- 1970 (292 with 2WD)
- 1973 (307, 350) Blazer, Jimmy, Suburban
- 1974 (350)
- F6779-1219-UA each** 18.95
- 1969 (292 with M/T)
- 1970-1972 (292)
- P6972-1219-UA each** 12.95
- 1971-72 (400)
- 1973-79 (Ser. 10/30, Suburban 454)
- P7172-1219-UA each** 24.95



CHROME RADIATOR SUPPORT COVER

Measures 29 7/8 x 6 3/8. Fits on top of radiator.
1973-80 Chevy truck automatic only

P7380-1220-CHA each 44.95



RADIATOR COOLANT OVERFLOW TANK

Fits All GM vehicles. Includes hoses, tank and sticker with correct wording. (Original sticker w/bowtie is available through other dealers.)

1939-54 Chevy/GMC
P3954-1240-A each 149.95



RECOVERY TANK CAP

1973 (C, K - 1, 2, 3 Blazer, Jimmy)
F7475-1240-A each 4.95

GIVE YOUR TRUCK THE CARE AND ATTENTION IT DESERVES WITH OUR SELECTION OF TOP QUALITY PARTS!



THERMOSTAT

- 1941-63 (6 cyl)
- 1955-63 V8
- 1964-66 (194, 230, 250, 292 without A/C)
- *180 degree*
- P4166-1246-A each** 7.95
- 1960-69 V6 All
- 1964-66 V8 with A/C
- 1964-66 (6 cyl. with A/C)
- 1967-78 (6 cyl. inline motors)
- 1967-68 V8
- 1969-77 V8 (exc. 396, 400, 402)
- *192-195 degree*
- P6478-1246-A each** 7.95
- 1937-58 All with std. trans (exc. 322 in V8 engine)
- 1963-78 (4.1L, 250)
- 1965-89 (4.8L, 292)
- 1966-91 (5.7L, 350)
- 1968-73 (5.0L, 307)
- 1970-80 (6.6L, 400)
- 1970-90 (7.4L, 454)
- 1973 (5.0L, 305)
- 1976-91 (5.0L, 305)
- 1979-84 (4.1L, 250)
- *180 degree*
- F6781-1246-A each** 7.95
- 1969-77 (396, 400, 402, 454)
- *192-195 degree*
- P6977-1246-A each** 7.95



THERMOSTAT GASKET

- 1937 58 All with Std. Trans (exc. 322 in V8 engine)
- 1963-78 (4.1L, 250)
- 1965-89 (4.8L, 292)
- 1966-91 (5.7L, 350)
- 1968-73 (5.0L, 307)
- 1970-80 (6.6L, 400)
- 1970-90 (7.4L, 454)
- 1973 (5.0L, 305)
- 1976-91 (5.0L, 305)
- 1979-84 (4.1L, 250)
- P7391-1252-A each**95

We appreciate your business!

ENGINE PARTS & GRILLS

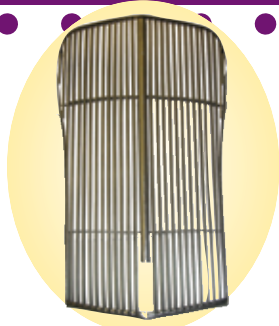

1937 GRILLE ASSEMBLY

Stamped steel - ready to paint or chrome.
1937 Chevrolet Pickup

P37-1266-A each 249.95

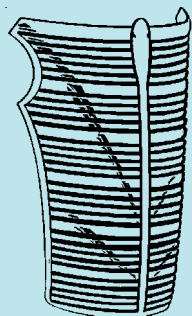

1938 GRILLE ASSEMBLY

Stamped steel (imported - plain steel). Ready to paint or chrome.

1938 Chevrolet Pickup

P38-1266-A each 249.95



1939 GRILLE ASSEMBLY

Stamped steel (imported plain steel). Ready to paint or chrome.

1939 Chevrolet Pickup

P39-1266-A each 249.95

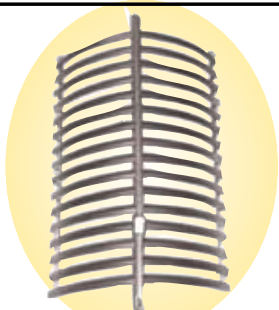

1940 GRILLE ASSEMBLY

Stamped steel - ready to paint or chrome.
1940 Chevrolet Pickup

P40-1266-A each 249.95

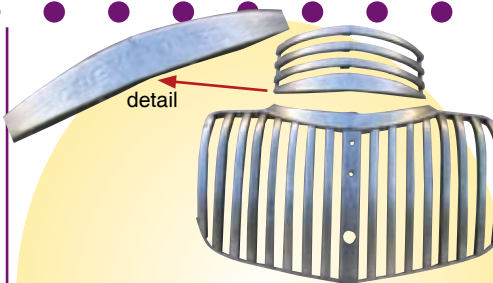

1941-46 GRILLE ASSEMBLY

Includes upper & lower section.

1941-46 Chevrolet Pickup

Stamped plain steel (imported). Ready for paint/chrome. Upper 1/2 does not have Chevrolet stamping.

P4146-1266-A each 339.95

1941-46 Chevrolet pickup, Panel, & Suburban
Chrome with correct "Chevrolet" stamping on the upper grill.

P4146-1266-CH each 699.95



angle view



front view



back view

1947-53 CHROME GRILLE

Completely assembled, quality reproduction!
Two years of testing, fitting, installing & making corrections until perfection was finally achieved. This is the #1 quality grill on the market! It has chrome bars with powder coated cream colored metal backing almost exactly as the original deluxe grill had.

1947-53 Chevrolet Pickup

P4753-1266-CHGA each 349.95



1947-53 CHROME GRILLE

1947-53 GMC Pickup

P4753-1266-GMC set 549.95



1947-53 BLACK STEEL GRILLE

Completely assembled, quality reproduction!

EDP coated, black. Primed - ready for paint.

1947-53 Chevrolet Pickup

P4753-1266-A set 249.95



1947-53 GRILLE BAR ASSEMBLY KIT

168 pieces - Includes All necessary nuts, bolts etc. to assemble the grill bars.

1947-53 Chevrolet Pickup

P4753-1266-MB set 15.95



1954-55 GRILLE NOSE

1954-55 Chevrolet Pickup

Steel grill center nose piece. Ready for paint or chrome.

P5455-1266-A each 99.95

1954-55 Chevrolet Pickup

Chrome plated grill bullet (or nose).

P5455-1266-AC each 149.95



1955-56 GRILLE ASSEMBLY

Chrome plated and pre-assembled. Ready to install.

1955-56 Chevrolet Pickup

P5556-1266-A each 299.95



GRILLES



NEW!

1955-57 INNER FRONT FENDER PANEL

Inner fender structure for headlamp & park lamp. Die stamped steel. 1 1/4 ft. x 2 ft.

1955-57 Chevrolet Pickup (Left hand)

P5557-1266-IHPL each 49.95

1955-57 Chevrolet Pickup (Right hand)

P5557-1266-IHPR each 49.95



STEEL GRILLE BAR

Reproduction steel grill bar.

1955-56 Chevy Pickup only

P5556-1266-GB each 79.95

1957 Chevy Pickup only

P57-1266-GB each 79.95

NEW!



1957 GRILLE ASSEMBLY

Chrome.

1957 Chevrolet Pickup

P57-1266-A each 699.95



1958-59 CHROME GRILLE ASSEMBLY

With black painted 'Chevrolet' lettering.

1958-59 Chevrolet Pickup

P5859-1266-CH each 349.95

NEW!



1958-59 FRONT GRILLE FILLER/SUPPORT PANEL

1958-59 Chevrolet Pickup

P5859-1272-A each 249.95



NEW!

1960-61 GRILLE SUPPORT PANEL

1960-61 Chevrolet Pickup

P6061-1266-SP each 359.95

NEW!



1963 GRILLE SUPPORT PANEL

1963 Chevrolet Pickup

P63-1266-SP each 359.95



1964-66 CHROME "CHEVROLET" GRILLE

1964-66 Chevrolet Pickup

P6466-1266-CH each 299.95



1967 GMC GRILLE

Triple chrome plated w/ black painted "GMC" letters.

1967 GMC Chevrolet Pickup

P67-1266-GMC each 499.95



1968-70 GMC GRILLE

Chrome grill with black painted details. Grill has the correct center bar different from the 1971-72. 1968-70 GMC Pickup

P6870-1266-GMC each 499.95

1969-70 RADIATOR GRILLE ASSEMBLY



1969-70 Ser. 10 thru 30 (exc. D-D)

Outer grill.

P6970-1266-A each 549.95



1969-70 Ser 10 thru 30 (exc. D-D)

Inner grill. Plastic - black and silver.

P6970-1266-B each 119.95



1969-70 Chevrolet Pickup, Blazer & Suburban
Reproduction outer grill. These grills are not stamped "Chevrolet" but rather include black decals.

P6970-1266-R each 299.95



1969-72 BILLET GRILLE

Use with 1971-72 outer grill.

1969-72 Chevrolet Pickup

P6972-1266-B each 199.95

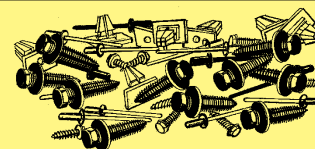

1969-72 GRILLE MOUNTING KIT

Contains 48 pieces including correct colored rivet clips & mounting bolts.

1969-72 Chevrolet Pickup

P6972-1266-MK kit 13.95

**More grilles
on the
next page!**

ENGINE PARTS & GRILLS



GRILLES



P7172-1266-B

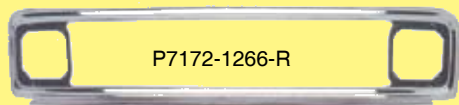

P7172-1266-R

RADIATOR GRILLE ASSEMBLY

1971-72 Ser. 10-30, Blazer (exc. D-D)
Outer grill. Original GM item.

P7172-1266-A each 549.95

1971-72 Chevrolet Pickup, Blazer, & Suburban.
Plastic inner grill.

P7172-1266-B each 119.95

1971-72 Chevrolet Pickup
Reproduction outer grill. Aluminum with black
painted details.

P7172-1266-R each 329.95



1971-72 GMC CHROME GRILLE ASSEMBLY

1971-72 GMC Chevrolet Pickup, Jimmy
Reproduction.

P7172-1266-GMC each 499.95



1973-80 REPLACEMENT GRILLE

1973-80 Chevrolet Pickup
Black, w/out bow-tie cut out.

P7380-1266-B each 49.95

1973-80 Chevrolet Pickup
Silver.

P7380-1266-S each 49.95



1977-79 GRILLE

1977-79 Chevrolet Pickup, Blazer
Light argent, exact reproduction for the 1977-79,
will fit 1973-80.

P7779-1266-A each 79.95

1977-79 Chevy pickup
Chrome replacement grill. No provision for bow
tie emblem.

P7779-1266-CH each 79.95

1978 Chevrolet Pickup (Sport)

P7879-1266-A each 269.95



1967-68 RADIATOR GRILLE MOULDING TRIM RING

Each pickup requires two pieces.
1967-68 (Ser. 10/30 with Custom pkg.)

P6768-1268-A each 89.95



NEW!

1967-68 GRILLE TRIM MOULDING CLIP SET

Set does one molding. 2 required per truck.
1967-68 Chevrolet Pickup

P6768-1268-CLP set 19.95

NEW!



1969-72 GMC TOP GRILLE BAR MOULDING

Fits above grill.
1969-72 GMC Chevrolet Pickup

P6972-1268-UGMC each 159.95

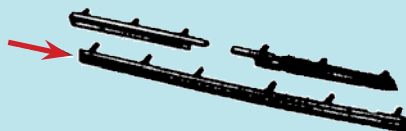

LOWER GRILLE MOULDING

1973-78 (C, K - 1,2,3, Blazer, Jimmy w/ chrome
grill)

Fitted on front end sheet metal grill hole opening.

P7378-1268-B each 12.95

1977-79 (C, K - 1,2,3, Blazer, Chevy Only)

Chrome moulding fitted on grill itself.

P7779-1268-AL each 74.95

1979-80 (C, K - 1,2,3 Blazer)

P7980-1268-B each 22.95

**Can't find it?
Call us -
we'll get it
for you!**



RADIATOR PANEL UPPER MOULDING

Fitted on front end sheet metal grill hole opening.
1973-78 (C, K - 1,2,3, Blazer, Jimmy with
Chrome grill)

P7378-1268-A each 12.95

1979-80 (C, K - 1,2,3)

P7980-1268-A each 19.95



RADIATOR SUPPORT TO FRAME PAD

1933-46 Chevrolet Pickup

P3346-1270-A pair 5.95

1947-49 Chevrolet Pickup

P4749-1270-AS each 3.95

1950-54 Chevrolet Pickup - 2nd Series in '55

P5054-1270-AS set of 4 3.95

1955-66 Chevrolet Pickup

P5566-1270-AS set of 4 6.95

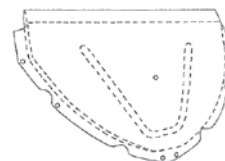

UPPER FILLER PANEL

Made of heavy gauge fiberglass. Upper radiator
support to grill.

1941-46 Chevy 1/2-3/4 ton only

P4146-1270-FP each 69.95



RADIATOR SUPPORT MOUNTING BOLT KIT

1947-54 Chevrolet Pickup

P4754-1270-MB kit 1.95

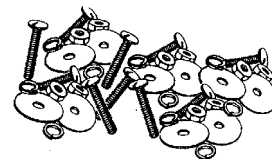

STAINLESS STEEL BOLT KIT

Radiator support, hood latch, splash pan, & front
body mounts. Stainless steel indented hex head
(original style).

1955-57 Chevrolet Pickup

P5557-1270-I kit 19.95

1958-59 Chevrolet Pickup

P5859-1270-I kit 34.95

1960-66 Chevrolet Pickup

P6066-1270-I kit 34.95



ENGINE PARTS & GRILLS



1960-66

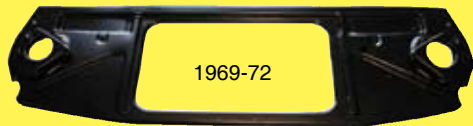

1969-72

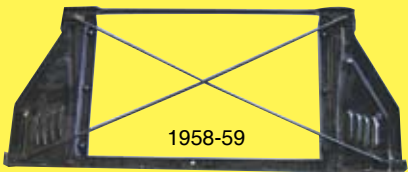

1958-59

RADIATOR SUPPORT, DIE STAMPED STEEL

- 1955-57 Chevrolet Pickup **NEW!**
- P5557-1270-A each** 209.95
- 1958-59 Chevrolet Pickup **NEW!**
- P5859-1270-A each** 209.95
- 1960-66 Chevrolet Pickup
- P6066-1270-A each** 149.95
- Complete with headlamp bracket.
- 1967-68 Ser. 10 thru 30 (exc. D-D)
- P6768-1270-A each** 199.95
- Complete with headlamp bracket.
- 1969-72 (Ser. 10/30 - (exc. D-D)
- P6972-1270-A each** 199.95



RADIATOR TO CORE SUPPORT RUBBER BUSHING

Used on 4 row radiator. 3-1/2" inside diameter.
1960-72 All
P6072-1270-4 each 5.95

1960-68



1969

RADIATOR SUPPORT TO FRAME NUT

(7/18" - 14). Requires 2 per vehicle.
1960-68 (Ser. 10/30 (exc. D-D)
1972 (Ser. 10/30 & Blazer (exc. D-D)
1972 Blazer
1971 (Ser. 20/30 (exc. D-D)
P6072-1270-MB each 4.95
1969 (Ser. 10/30 (exc. D-D)
P69-1270-MB each 1.95



LOWER RADIATOR MOUNTING PAD SET

Fits both 8 and 6 cylinder models.
1963-66 Chevy/GMC Pickup
P6366-1270-L pair 7.95



UPPER RADIATOR MOUNTING PADS

Fits six or eight cylinder models.
1963-66 Chevy/GMC Pickup
P6366-1270-U pair 7.95

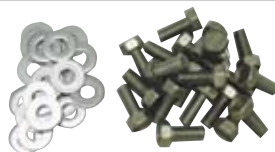

RADIATOR SUPPORT BOLT KIT

Stainless steel indented hex head bolt kit to mount the radiator in the support.
1967-72 Chevrolet Pickup
P6772-1270-IR kit 12.95

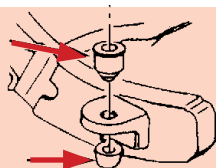

RADIATOR CORE SUPPORT CUSHION

Both upper and lower, bolts not included.
1967-72 Pickup
P6772-1270-set 4 piece set 26.95



1968-72 TRUCK RADIATOR CUSHIONS

Upper & lower.
1968-72 Chevy/GMC 4 core with A/C or 4 X 4
P6872-1270-INS pair 7.95

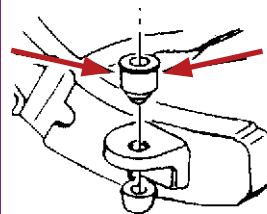

UPPER SUPPORT CUSHION

Req. 2 per vehicle.
1969-72 (Ser. 10/30, Blazer (exc. D-D)
P6972-1270-UCB each 12.95
1973-78 (C 2, 3)
1979-80 Chevrolet Pickup, Suburban
1979-80 (C 2, 3)
1979-80 (C 3)
P7380-1270-A each 49.95

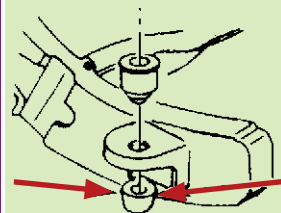

LOWER SUPPORT CUSHION

Req. 2 per vehicle.
1969 (Ser. 10 exc. 4WD)
1969-71 Blazer 4WD
1969-72 (Ser. 20 Single unit)
1970-71 (Ser. 10 exc. 4WD & D-D)
1971 Blazer
P6972-1270-LC each 9.95
1969-70 (Ser. 10 4WD) - 200/300 FFC
1971-72 (Ser. 20/30)
1971-72 (Ser. 10 4WD & Blazer)
P6972-1270-LCB each 11.95
1973-78 Chevrolet Pickup
1979 (Ser. 20/30)
1979-80 Chevrolet Pickup, Suburban
P7380-1270-B each 9.95



RADIATOR BATTERY HOOD BOLTS

Radiator support, battery box, & hood latch bolt kit. Indented hex head, stainless steel.
1973-80 Chevy
P7380-1270-I kit 29.95



Gotta question?
Email us at
info@classicchevroletparts.com

We accept
Visa,
Master Card,
and Discover.

ENGINE PARTS & GRILLS

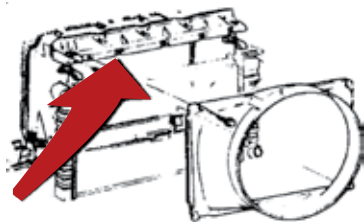

RADIATOR UPPER MOUNTING PANEL

1973-77 All
 1975-77 Blazer, Jimmy 400 - 4WD
 1978 Chevrolet Pickup 305, 350 with A/T, AC
 1978-80 (CK 2,3, 305, 350 with A/T AC, H.D. Rad)
 1979-80 Chevrolet Pickup 400 - 4WD
P7380-1270-P each 19.95
 1978 Chevrolet Pickup 250, 292 with A/T
 1978 Chevrolet Pickup 250, 292 with M/T, A/C
 1979-80 Chevrolet Pickup 305, 350 with M/T
 1979-80 All 6 cyl.
 1979-80 All 305, 350 with M/T
P7880-1270-PN each 29.95



RADIATOR INSULATOR

62.0 mm cutout.
 1973 Chevrolet Pickup
 1977-78 Chevrolet Pickup
 1979-80 (6 Cyl.)
 1979-80 All 305, 350 with A/T, (exc. AC, H.D. Rad or with M/T)
F7681-1270-INS each 4.95



STEEL FRONT SPLASH APRON

Fits between bumper and grill. EPD black primer.
 1947-53 Chevrolet Pickup
P4753-1272-A each 79.95
 1954-55 1st Ser. Pickup
P5455-1272-A each 89.95



CHROME FRONT SPLASH APRON

Fits between bumper and grill. Chrome plated steel.
 1947-53 Chevy
P4753-1272-CH each 199.95
 1954-55 1st Ser. Pickup
P5455-1272-CH each 199.95



FIBERGLASS FRONT SPLASH APRON

Fits between bumper and grill.
 1941-46 Chevrolet Pickup
P4146-1272-FG each 74.95
 1947-53 GMC only
P4753-1272-GMC each 119.95

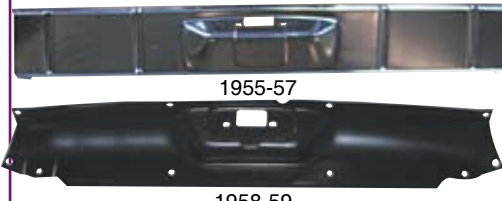

1955-57

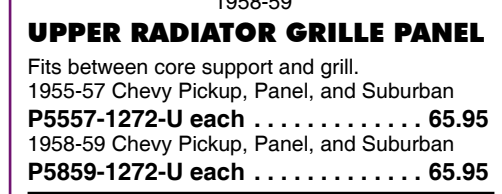

1958-59

UPPER RADIATOR GRILLE PANEL

Fits between core support and grill.
 1955-57 Chevy Pickup, Panel, and Suburban
P5557-1272-U each 65.95
 1958-59 Chevy Pickup, Panel, and Suburban
P5859-1272-U each 65.95



BUMPER TO GRILLE FILLER PANEL

1967-68 Pickup, Suburban, and Panel.
P6768-1272-A each 69.95



RADIATOR FAN SHROUD

1963-66 (Ser. 10/30 283, 327)
 Round - plastic
P6366-1277-FSA each 109.95
 1969-72 Chevrolet Pickup
 Big block ABS plastic fan shroud
P6972-1277-ABS each 159.95
 1969-72 Chevrolet Pickup
 Big block fiberglass fan shroud
P6972-1277-FG each 199.95
 1970-72 (Ser. 10/30, Blazer Conv. 8 cyl.) Fits all (exc. 4WD, DD, A/C, P/S, A/T, 400 or 396 engines)
 Small block without air
P7072-1277-FSA each 109.95
 1970-72 (Ser. 10/30 4WD, D-D 8 cyl)
 Small block 4wd
P7072-1277-FSB each 109.95
 1970-72 (C10/30, 2WD with A/C (exc. Big Block)
 Small block with a/c
P7072-1277-AC each 94.95
 1973-77 (C, K - 1,2,3, Blazer, Jimmy 305, 307, 350)
P7377-1277-A each 109.95
 1973-78 All
P7378-1277-B each 84.95



1941-46



1971-72

CHROME GRILLE EMBLEM

1941-46 Chevrolet Pickup
 With red & blue paint
P4146-1303-A each 34.95
 1971-72 Ser. 10-30, Blazer (exc. D-D)
P7172-1303-A each 49.95

CHEVROLET

BLACK GRILLE LETTERS

"Chevrolet" decal
 1958-59 Chevrolet Pickup
P5859-1303-A set 12.95
 1964-66 Chevrolet Pickup
P6466-1303-A set 12.95



PLASTIC GRILLE NUT

1969-72 Chevrolet Pickup
P6972-1303-MB each95



GRILLE MOULDING RETAINER

Req. 28 per vehicle.
 1967-68 Chevrolet Pickup
P7172-1303-MB each 1.95



GMC GRILLE EMBLEM

GMC grill emblem
 1979-80 (C, K - 1,2,3 GMC Pickup)
P7980-1303-AG each 29.95

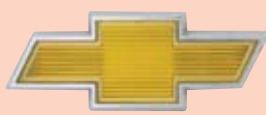

GRILLE EMBLEM

1980 (C, K - 1,2,3 with Chrome Grill)
P80-1303-A each 59.95



ENGINE PARTS & GRILLS



CRANKCASE GROMMET

1964-71 All 6 cyl
15/16" id x 1-7/32" od

P-1745-G each 1.95



VENT HOSE GROMMET

1970-72 All & Blazer
Vent hose to A/CI connector, vent, valve, vent
flame arrestor.

P7072-1745-G each 1.95



OIL FILLER CAP

1938-48 All (exc. D-D)
1955-63 All 6 cyl. (exc. 261)
1964-66 All (exc. D-D - 8 cyl.)
1964-67 All 6 cyl.
Painted - 4 vent holes - 2-3/4" o.d.

P3867-1758-A each 16.95

1955-59 (8 cyl.)
1960-61 (283)
1962 (6 cyl.)
1963 (8 cyl.)
1964-67 (283, 327)

Air breather type.

P5567-1758-A each 9.95

1955-59 Chevrolet Pickup 6 cyl. 1500 to 4400
1959 Apache
1962 (4 & 6 cyl.)
1963-67 (6 cyl. - (exc. Hi Torque 292)

F67-1758-A each 9.95

1949-54 Chevrolet Pickup
1966 (396)
1967 (327)
1968-70 & 74 All V8 (exc. 454)
1975-85 All

F6881-1758-A each 3.95

1971-73 & 74 All 6 cyl. & 454 V8

F7174-1758-A each 1.95



OIL PRESSURE SWITCH

1970-72 (Ser. 10/30 without tach gauge)
1970-72 All & Blazer
1973-74 All
1976-77 (250, 305, 350)
1976-77 with H.D. chassis, 454
1976-77 Blazer, Jimmy 2 or 4 WD
1978 exc. gauges
1979-80 All 8 cyl. (exc. gauges)
2 21/32 " o.l.

P7072-1800-A each 9.95

1970-74 All

For vehicles with warning lights - no gauges.

F7074-1800-A each 11.95



1955-59



1967-72

OIL PRESSURE GAUGE

1947-49 Chevy Pickup
Red needle.



P4749-1803-A each 59.95

1950-53 Chevy Pickup
White needle.



P5053-1803-A each 59.95

1955-59 Truck

P5559-1803-A each 79.95

1967-72 Chevy/GMC Pickup, Blazer, & Suburban.

P6772-1803-A each 79.95

Classic Chevrolet Parts Inc.

8723 S. I-35

Oklahoma City, OK 73149

Summer Store Hours:

Monday – Friday
8 a.m. thru 6 p.m.

Saturday
8 a.m. thru 12 p.m.

Winter Store Hours:

Monday – Friday
8 a.m. thru 5 p.m.

Saturday
8 a.m. thru 12 p.m.

[Central Standard Time]

Stop by our showroom!

Chevy...



American Made



OIL PRESSURE SENDING UNITS

1960-63 Ser. 10-30 (exc. FFC, DD, Tachometer)

B5657-1800-A each 79.95





STARTER DRIVE

(Also called bendix)

1938-54 Chevy

1947-62 GMC

P3862-2086-A each39.95



1955-60



1938-48

STARTER SWITCH/SOLENOID

1938-48 Chevy

Floor mount.

P3848-2100-A each24.95

1949-54 Chevy

Solenoid switch for 6 volt systems.

P4954-2100-A each79.95

1955-60 Chevy

Starter switch for 12 volt systems.

P5560-2100-A each74.95

1956-59 Chevy

Floor mount.

P5659-2100-A each32.95

1961-72 Chevy

Solenoid switch for 12 volt systems.

P6172-2100-A each106.95



FOOT STARTER PEDAL PAD

1947-59 Chevy

P4759-2100-P each5.95



IGNITION BALLAST RESISTOR

Mounts near the coils in the ignition assembly.

Mounts on firewall in many applications.

1955-59 Pickup

P5559-2173-A each10.95



check us out at

www.classicchevroletparts.com



OCTAGON HEAD GM KEY BLANK

With knockout plug ignition, door & tire locks.

Also acts as a glove box door lock for certain years- see below.

1938-66 All

1947-62 (Glove box Door Lock)

P3866-2187-A each3.95

1955-66 GM models

P5566-2187-A each1.95

1967 GM models

Original 1967 style. Coded 'a' on key shaft.

P67-2187-A each4.95

1968 GM models

Original 1968 style. Coded 'c' on key shaft.

P68-2187-A each4.95



PEARHEAD GM KEY BLANK

1955-66 GM models

P5566-2187-B each1.95

1967 GM models

Original 1967 style. Coded 'b' on key shaft.

P67-2187-B each4.95

1968 GM models

Original GM 1968 style. Coded 'd' on key shaft.

P68-2187-B each4.95



SQUARE HEAD ORIGINAL GM KEYS

1975 All Blazer

A67-2187-SH each95

1967 GM models

1971 GM models

Current GM replacement style.

P6771-2187-A each95

1968 GM models

1972 GM models

Current GM replacement style.

P6872-2187-A each95

1969 GM models

P69-2187-A each95

1970 GM models

P70-2187-A each95

1976 All, Blazer (Chevy Only)

1980 All

F6880-2187-SK each3.95

1973-77 All, Blazer (Chevy Only)

F6981-2187-SK each3.95

1974-78 All, Blazer

F7078-2187-SK each3.95



ROUND/OVAL HEAD GM KEY BLANK

1967 All

1971 All

Round head. Current GM replacement style.

P6771-2187-B each95

1968 GM Models

1972 GM Models

Round head. Current GM replacement style.

P6872-2187-B each95

1976 All, Blazer (Chevy Only)

1980 All

Oval head.

F6880-2187-OK each2.95

1969 GM Models

Round head.

P69-2187-B each95

1973-78 All, Blazer (Chevy Only)

Oval head.

F6981-2187-K each2.95

1970 GM Models

Round head.

P70-2187-B each95

1974 All, Blazer (Chevy Only)

1978 100/300

Oval head.

F7078-2187-OK each3.95

1975 All, Blazer (Chevy Only)

Oval head.

F7179-2187-OK each3.95



1947-53

1955-59

1967-72

1973-76

IGNITION SWITCHES

1947-53 Chevy and GMC Pickup

Ignition switch for six cylinder floor foot start application

P4753-2188-A each32.95

1954-55 Chevy Pickup.

Fits 54 and early 55 series only.

P5455-2188-A each49.95

1955-59 Pickup

P5556-2188-A each39.95

1962-67 Chevy

5 terminals.

P6267-2188-A each14.95

1967-72 Chevy

P6780-2188-A each19.95

1973-76 All without Tilt Wheel

1977-90 All without Tilt Wheel

Column mounted, no tilt column.

F7081-2188-A each14.95

1973-76 All

1977-90 All with Tilt Wheel

With tilt or telescoping wheel.

F7081-2188-B each11.95

Email your questions, comments or orders to
info@classicchevroletparts.com



CHASSIS & ELECTRICAL



IGNITION KEY & TUMBLER

1935 Chevy
Ignition switch lock tumbler with keys.
P35-2188-AS each28.95
1947-66 Pickup
Ignition switch cylinder & keys. Replacement style.
P4754-2188-A set12.95
1960-61 Chevy
Ignition switch lock tumbler w/ keys. Original style.
P6061-2188-AS each47.95
1967-68 Chevy
Original style ignition lock cylinder & keys.
P6768-2188-A set16.95
1967-72 Chevy
Ignition switch cylinder with key. Aftermarket.
P6772-2188-A set10.95
1973-78 Pickup
Ignition lock w/cylinder & keys (late style w/ square head key).
F6978-2188-L each17.95



IGNITION SWITCH, KEY & TUMBLER SET
1955-59 Pickup
Ignition switch with cylinder and keys.
B5556-2188-set each99.95



UNIVERSAL IGNITION SWITCH
All
Universal four position ignition switch with cylinder and keys, mounts in dash.
U-2188-AS each19.95



IGNITION & DOOR LOCK SET
1967-68 Chevy
Original style ignition & door lock cylinder & keys.
P6768-2188/328-AS set36.95
1967-72 Chevy & GMC
Replacement style ignition & door lock cylinder set.
P6772-2188/328-AS set32.95
1973-78 Pickup
Door & ignition lock kit w/cylinders & keys (late style w/square head keys, "short" cylinder for 1970.)
F6970-2188-LK set39.95



IGNITION SWITCH PLUG W/WIRE
1967-72 Pickup
P6772-2188-PL each16.95

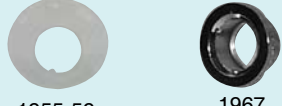

IGNITION SWITCH BEZEL
1955-59 Chevrolet Pickup (clear plastic)
P5559-2198-A each5.95
1968-70 All
1971-72 (Ser. 10/30 exc. D-D) (chrome)
P6872-2198-SB each9.95
1967 Pickup (chrome)
P67-2198-SB each6.95



1955-59 IGNITION SWITCH RETAINING NUT
Stainless steel.
1955-59 Chevrolet
P5559-2198-SB each5.95



IGNITION INDICATOR PLATE
1967-72 Pickup
P6772-2198-A each4.95



IGNITION SWITCH RETAINER
Behind dash.
1968-72 Pickup
P6872-2198-SR each6.95



SPARK PLUG WIRE GROMMET
Rear upper and lower - four 8/23" holes.
1955-63 All
P5563-2251-G each2.95



SPARK PLUG WIRE RETAINER
1973-74 All
2-wire.
P7374-2251-A each4.95
1973-74 All
1975-81 All, Blazer, Jimmy 305, 350, 400
F7581-2251-WR each1.95
1975-76 (100/300, 454)
1979-81 All
Clip off excess retainer for use with 8 mm cable.
P7581-2251-R each95
1979-80 All
Bracket mount w/link top retainer (4 wire)
F7681-2251-TR each1.95
1973-74 All
1974 (Ser. 10/30, 350)
1975-78 Pickup, Blazer, Jimmy - on Valve Cover
1979-81 All 305, 350, 400
2 wire & cdt, rose bud mt
F8081-2251-WR each10.95



SPARK PLUG WIRE SUPPORT
Rear left, front, right rear side.
1974 All
P74-2251-A each2.95
1976-80 (Ser. 10/30, Blazer, Jimmy 305, 350, 400 - exc. Diesel)
F7681-2251-SWS each2.95



BIG BLOCK ALTERNATOR STUD WITH NUT
1968-72 Pickup (Big Block only)
A6972-2277-AS each9.95



GENERATOR BRUSH
Requires 2 per vehicle.
1955-62 All
P5562-2285-A each12.95



GENERATOR BRUSH SPRING
5/16" od - 12 3/4" coils. Requires 2.
1952-62 All
P5262-2286-A each2.95

CHASSIS & ELECTRICAL



BATTERY MAT

This mat absorbs acid. Made of super absorbent polypropylene needle punch felt, w/one side heat treated to give it additional strength. This fabric is slowly pressure-treated at high temperatures with a unique, all-natural neutralizing formula and then cured in ovens. Finally, the fabric is dipped in a latex sealant mixture, cured again in the ovens, and is printed.

M-96-BMAT each5.95



ALTERNATOR BRACKET

Upper alternator adjusting bracket.
1967-69 GM Big Block

F6769-2317-A each34.95

1969-71 All

A6971-2317-SP each19.95



1958-59



1960-66

STAINLESS STEEL BATTERY TRAY ASSEMBLY

1955-57 Pickup
Stainless steel.

P5557-2333-S each99.95

1958-59 Pickup
Stainless steel.

P5859-2333-S each99.95

1960-66 Pickup
Stainless steel.

P6066-2333-S each99.95

1967-72 Pickup
Stainless steel.

P6772-2333-S each99.95

1967-72 Pickup, Blazer, and Suburban

Stainless steel battery tray with a/c line bracket.

P6772-2333-SSAC each99.95

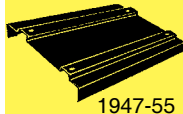

1947-55



1955-57



1958-59

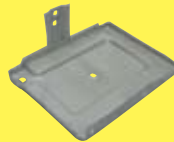

1960-66



1967-72



1973-78

BATTERY TRAY

1947-55 (1st Series) Chevy Stepside Pickup
Tray only

P4755-2333-A each11.95

1955-57 Chevrolet Stepside Pickup
Unpainted, tray only.

P5557-2333-A each24.95

1958-59 Chevrolet Pickup (Unpainted, tray only)

P5859-2333-A each29.95

1960-66 Chevrolet Pickup (Unpainted, tray only)

P6066-2333-A each29.95

1967-72 Stepside/Fleetside

Tray only, unpainted, ready to weld to old supports.

P6772-2333-A each29.95

1973-78 (Ser. 10/30, Blazer, Jimmy)

1979-80 All 250, 305, 350, 454

Also used with auxiliary battery, tray only.

P7380-2333-C each14.95



1955-57



1960-66



1947-55

BATTERY TRAY ASSEMBLY

1932-36 Pickup

Includes tray, sides, & frame mounting bolts.

P3236-2333-A each89.95

1936-46 Pickup

P3646-2333-A each62.95

1947-55 (1st. Series) Chevy Pickup

Complete with bottom, sides, and hold down bolts.

P4755-2333-ASSY each79.95

1955-57 Chevrolet Pickup (Painted)

P5557-2333-ASSY each44.95

1958-59 Chevrolet Stepside Pickup

Complete painted battery box assembly.

P5859-2333-ASSY each44.95

1960-66 Chevrolet Pickup

Complete painted battery box assembly.

P6066-2333-ASSY each44.95

1967-72 Chevy

Complete battery box, painted, with a/c bracket

P6772-2333-AC each69.95

1967-72 Chevrolet Pickup

Complete painted battery box assembly without a/c bracket.

P6772-2333-ASSY each59.95



BATTERY TRAY SUPPORT

1973-78 Pickup, Blazer - with Aux. Battery

1979 All

1980 All 250, 305, 350, 454 - with Aux. Battery

P7380-2333-B each24.95



BATTERY HOLD DOWN PADS

1937-57 Pickup

P3757-2333-AS set of 44.95



1947-55



1955-57

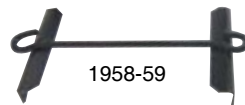

1958-59

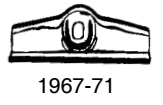

1967-71

BATTERY HOLD DOWN

1947-55 Pickup

P4754-2335-A each14.95

1955-57 Pickup

P5557-2335-A each14.95

1958-59 All

1960-65 (Ser. 10/30 (exc. D-D))

1961-72 (100 D-D)

8-1/2" o.l. x 4"

P5872-2335-A each7.95

Same as F6781-2333-CLP

1967-71 (Ser. 10/30 All (exc. D-D))

1973-78 (Ser. 10/30, Blazer, Jimmy with auxiliary battery)

P6771-2335-A each1.95

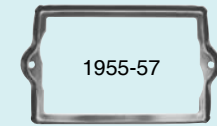

1955-57

STAINLESS STEEL BATTERY HOLD DOWN

1955-57 Pickup (Stainless steel)

P5557-2335-SS each42.95

1958-59 Pickup (Stainless steel)

P5859-2333-SS each34.95





CHASSIS & ELECTRICAL

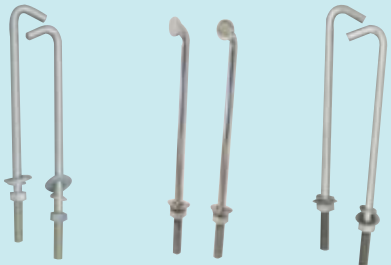

1955-57, plain 1958-59 1955-57, stainless

BATTERY HOLD DOWN HARDWARE

- 1955-57 Pickup (Plain steel)
- P5557-2335-SB each9.95**
- 1955-57 Pickup (Stainless steel)
- P5557-2335-SSB each22.95**
- 1958-59 Pickup (Stainless steel)
- P5859-2333-SSB each22.95**
- 1960-66 Pickup (Stainless steel)
- P6066-2333-SS each34.95**
- 1960-66 Pickup (Stainless steel)
- P6066-2333-SSB each22.95**



BATTERY HANGER CLAMP BOLT

Hook head 5/16" - 18 x 10-1/2" ol
1955-57 (Ser. 30)
1960-66 All

- P5566-2334-A each4.95**



BATTERY BOX BOLT KIT

Stainless steel w/ indented hex head.
1967-72 Pickup

- P6772-2334-IB kit.3.95**



BATTERY GROUND STRAP

Braided - 14" long

- P-2341-A each12.95**

Braided - 12" long

- P-2341-B each12.95**



ENGINE GROUND STRAP

1967-69 (Ser. 10/30 (exc. FFC & D-D)
1976-77 (Ser. 30 Cab)
1978 All
(10 1/2")

- P6770-2341-EGS each19.95**

1973-78 (Ser. 10/30, Blazer, Jimmy)
(19")

- P7378-2341-A each29.95**



BATTERY DISCONNECT SWITCH

Helps prevent fire & theft. Instructions included.

- U-2343-DS each26.95**



DISTRIBUTOR CAP

1949-62 Chevy (6 Cyl)
1953-59 GMC (6 Cyl)
1961-62 GMC (270 6 cyl)

- P5762-2367-A each16.95**

1957-72 (8 cyl.)

- P5772-2367-A each6.95**



DISTRIBUTOR ROTOR

1927-28 Chevy
1934-35 GM

Use with P2728-2367-A cap.

- P2735-2382-A each9.95**

1929-48 Chevy

1953-59 GM

Use with P2952-2367-A.

- P2952-2382-A each6.95**

1955-56 All 8 cyl.

- P5556-2382-A each6.95**

1949-62 Chevy, 6 cly.

Use with P5762-2367-A cap.

- P5762-2382-AS each6.95**

1957-74 Chevy, Blazer 8 cyl.

- P5772-2382-A each4.95**

1963-68 Chevy 4 Cyl

1963-74 Chevy 6 Cyl

Use with P6372-2367-A cap.

- P6374-2382-AS each6.95**

1975-80 All 8 cyl. with H.E. Ignition

1978-79 All 6 cyl. with H.E. Ignition

1980 All 6 cyl.

Use with F7481-2367-A cap.

- F7481-2382-A each9.95**

1975-77 All 6 cyl. with H.E. Ignition

Use with F7577-2367-A cap

- F7577-2382-A each12.95**



IGNITION POINTS

1927-28 Chevy 4 cyl.

1934-35 GM 6 cyl.

Heavy duty.

- P2735-2384-A set.16.95**

1941-48 Chevy 6 cyl.

Heavy duty.

- P4148-2384-A each14.95**

1955-56 GM 8 cyl.

Heavy duty.

- P5556-2384-A set.24.95**

1929-40 Chevy 6 cyl.

1947-61 GM 6 cyl.

1949-62 Chevy 6 cyl.

- P5762-2384-A each9.95**

1957-74 (8 cyl.)

Consists of breaker arm & support.

- P5774-2384-A each3.95**

1963-72 Chevy 4 & 6 cyl.

1964-66 GM 4 cyl.

1964-72 GM 6 cyl.

Consists of breaker arm & support.

- P6372-2384-A each8.95**

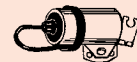

DISTRIBUTOR CONDENSER

1929-62 Chevy 6 cyl.

1934-58 GM 6 cyl.

1955-56 GM 8 cyl.

1955-59 Chevy 8 cyl.

1963 GM 6 cyl.

1964-66 GM 4 cyl.

Wire length 2 15/32"

- P2969-2393-A each5.95**



IGNITION COIL

1932-54 (6 volt ignition coil)

Metal encased, oil filled - (*must use external resistor!*)

- P2748-2394-A each54.95**

1955-72 (12 volt ignition coil)

Metal encased, oil filled - (*must use external resistor!*)

- P5772-2394-A each17.95**



VACUUM ADVANCE MECHANISM

For distributor vacuum control.

1947-62 Chevy Truck & 54-55 GMC Truck (6 cyl)

- P4655-2410-A each9.95**

We appreciate your business!

CHASSIS & ELECTRICAL



FUEL LINKAGE ROD CLIP

RH type.
1955-72 All body styles
B-2425-RH each 1.95

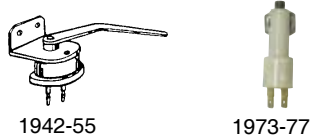

BRAKE LIGHT SWITCH

1942-55 Chevy
Mechanical type with snap on terminals.
P4255-2447-A each 39.95
1955-61 GMC Pickup
1955-64 Chevy
1964-65 GMC Pickup
Mechanical with snap on terminal.
P5559-2447-A each 26.95
1960-77 Chevy
P6072-2447-A each 9.95
1973-77 All
1978 Ser. 10/30 (exc. P.B. Cruise Control)
1979 All (exc. Cruise Control)
1980-81 All with M/T
F6779-2447-A each 9.95

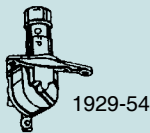

DIMMER SWITCH

1929-54 Chevy
Universal, 3 terminal type, die cast with 3 hole mount.
P4654-2459-A each 19.95
1955-57 Chevy
3 slip terminal type, die cast - 2 hole mount.
P5557-2459-A each 29.95
1957-60 Chevy Truck
1957-60 GM Truck with 2 Hole mounting flange
1965-67 Chevy Truck
3 slip terminal type, die cast 2 hole mount.
P5867-2459-A each 19.95
1961-72 GM Pickup
1961-67 Chevy Pickup
1968 Chevy Van
1969 Chevy Truck
1970-81 All
Includes all GM floor mounted models. (Replaces GM #'s 1997037, 12338706, 1997028, 1997031, 1997035, 1997036, 1997040.)
F6781-2459-A each 5.95

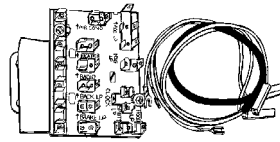

ELECTRIC FUSE BLOCK

With primary wiring.
1955-59 Pickup
P5559-2480-A each 29.95

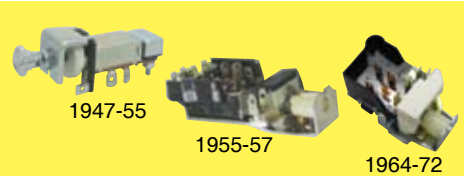

HEADLIGHT SWITCH

1940-46 Pickup
P4046-2485-A each 11.95
1946-55 Pickup
Replacement headlamp switch with knob for 12 volt system.
P4655-2485-A each 59.95
1947-55 Chevy/GMC Pickup
12 volt original style headlamp switch. Accepts original knob/shaft.
P4755-2485-12 each 59.95
1947-55 Chevy/GMC Pickup
6 volt original style headlamp switch. Accepts original headlamp knob.
P4755-2485-6 each 59.95
1955-57 (12V)
1958-59 Ser. 30
1960-62 D-D (exc. 102" W.B.)
P5562-2485-A each 36.95
1960-63 Chevy Pickup
P6063-2485-A each 59.95
1964-72 All
P6472-2485-A each 19.99
1974-84 All
F6981-2485-A each 15.95



HEADLIGHT KNOB

1936-39 Pickup
Black.
P3639-2486-A each 9.95
1940-46 Pickup
Rose tan.
P4046-2486-A each 9.95
1947-53 Pickup
Maroon, with shaft
P4753-2486-A each 9.95
1947-53 Pickup
Maroon, without shaft
P4753-2486-K each 9.95
1954-55 Pickup
Black.
P5455-2486-A each 8.95
1954-59 Pickup
With shaft.
P54-2486-A each 9.95
1955-59 Pickup
Rod & knob, chrome.
P5559-2486-A each 11.95
1955-59 Pickup
Black.
P5559-2486-KB each 9.95
1955-59 Pickup
Chrome.
P5559-2486-KC each 9.95
1960-63 Chevrolet Pickup
Knob w/rod.
P6063-2486-A each 11.95
1964-66 Chevrolet Pickup
Knob w/rod.
P6466-2486-A each 11.95
1967-68 Chevy / GMC
Rod & knob, black w/ stainless steel center (small knob type).
P6768-2486-A each 9.95
1968-72 Pickup
Rod with knob.
P6872-2486-A each 9.95



HEADLIGHT SWITCH RETAINING NUT

Stainless steel.
1955-59 Pickup
P5559-2487-NT each 8.95



LIGHT SWITCH ROD NUT

1975-84 (Ser. 10/30, Blazer, Jimmy)
P7584-2487-A each 7.95

Gotta tough question?
Joe is ready to help!

**Why wait?
Don't punish your truck any longer.
Get it now!**



CHASSIS & ELECTRICAL



VOLTAGE REGULATOR

1940-54 Pickup 1st Series - 6 volt only
For 6 volt systems. 3 unit type - neg. ground.

P4054-2500-A each99.95

1955-62 Pickup (exc. 30 amp - 12 volt)
For 12 volt systems. 3 unit type with pos. or neg. ground.

P5562-2500-A each99.95

1955-62 Pickup 30 amp only - 12 volt

P5562-2500-B each19.95

1963-72 Pickup 12 volt
2 unit type - neg. ground

P6372-2500-A each14.95



VOLTAGE REGULATOR MOUNTING KIT

1967-72 Pickup

P6772-2500-MK kit5.95



1950-53



1955-59



1967-72

AMMETER GAUGE ASSEMBLY

1947-49 Chevy Pickup
With red needle.

P4749-2515-A each59.95

1950-53 Chevy Pickup
With white needle.

P5053-2515-A each59.95

1955-59 Pickup

P5559-2515-A each79.95

1967-72 (100/300 (exc. dbl. duty)
Exact reproduction of the original.

P6772-2515-B each24.95

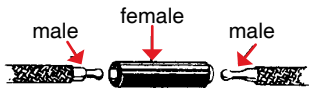

MALE/FEMALE WIRE CONNECTORS

1928-72 All Chevrolet
MALE wire connectors.

B-2530-BS set of 102.95

1928-80 All Chevrolet

Single FEMALE wiring connectors. Allows one
male wire to plug from each end.

B-2530-K set of 104.95



WIRING CONNECTION BODY

1938-72 All
4-way.

P-2530-4A each3.95



TERMINAL BLOCK

Inner fender junction block.
1947-54 Pickup

P4753-2530-TB pair24.95



CHASSIS WIRING HARNESS CLIP

1938-70 All
Engine wiring - strap type - rubber coated.

P3870-2559-A each4.95

1938-72 All

Bolt on type, rubber coated - 2" ol.

P3872-2559-A each95



SIGNAL & HAZARD LIGHT FLASHER

1948-54 Pickup
3 terminal flasher.

P4854-2575-A each9.95

1955-72 All

2 prong flasher.

P3872-2575-A each3.95

1955-59 Pickup

P5559-2592-A each5.95

1964-72 Chevy

P6472-2575-A each5.95



HAZARD SWITCH KNOB

One piece design.
1967-70 All

1971-72 (Ser. 10/30, Blazer)

P6772-2575-A each3.95



CARGO LIGHT HOUSING

Housing only.
1967-72 Pickup

P6772-2575-CLH each34.95



CARGO LIGHT KIT

Includes: housing, lens, gaskets, bulb, screws,
retainers, & harness.

1967-72 Pickup

P6772-2575-kit kit69.95

Show off your Truck!

Give your baby the TLC it deserves with our great selection of items!



SAVE ON SHIPPING! WE DELIVER TO ANY SWAP MEET WE ATTEND. JUST ASK FOR DETAILS!

We accept Visa, Master Card, and Discover.

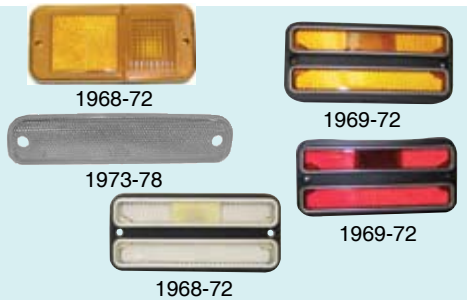

SIDE MARKER LAMP

- 1968-72 Pickup
Amber front side marker lamp without chrome trim.
P6872-2575-A each 8.95
- 1968-72 Chevy
Red rear side marker lamp assembly without chrome trim.
P6872-2575-B each 8.95
- 1968-72 Chevy Pickup
Clear sidemarker with trim.
P6872-2575-CL each 14.95
- 1969-72 Ser 10-30
Amber front side marker lamp with chrome trim. **May be necessary to cover socket hole depending on app.**
P6972-2575-A each 14.95
- 1969-72 Ser 10-30
Red rear side market lamp with chrome trim. **May be necessary to cover socket hole depending on app.**
P6972-2575-B each 12.95
- 1973-78 Pickup
Red rear side marker lamp lens, w/o trim.
P7378-2575-B each 12.95
- 1973-78 Ser 10-30
Red rear side marker lamp lens, w/trim.
P7378-2575-C each 12.95
- 1973-80 Pickup
Amber front side marker lamp lens, w/o trim.
P7380-2575-A each 12.95
- 1973-80 Pickup
Amber front side marker lamp lens, w/trim.
P7380-2575-B each 12.95



SIDE MARKER LIGHT SCREWS

- Does all 4 lights and includes j-nuts.
1968-72 Pickup
P6872-2575-SC set 2.95



CARGO LAMP LENS

- 1967-72 All
P7072-2575-CLA each 9.95



ROOF MARKER LAMP LENS

- Requires 5 per vehicle.
1970 Ser 10-20 with Roof Marker
1971-72 Ser 10-20, Suburban, with Roof Marker.
(Amber marker lamp lens).
P7072-2575-AMB each 8.95
- 1970-72 All (amber)
P7072-2575-RML each 12.95



CARGO LAMP LENS SCREWS

- Replacement type.
1970-72 Pickup
P7072-2575-SC set 95



CARGO LAMP MOUNTING KIT

- Original style, contains 2 well nuts, mounting screws and lens screws.
1970-72 Pickup
P7072-2575-SCO kit 2.95



PARK LIGHT/TURN SIGNAL CONVERSION KIT

- 1947-53 Pickup (12v)
Includes wiring, bracket & bulb.
P4753-2585-K kit 8.95
- 1954-55 Pickup (12v)
Includes wiring & socket.
P5455-2585-K kit 8.95



CLEAR PARK LIGHT CONVERSION KIT

- Includes 2 amber park light bulbs, 2 park lamp gaskets, 2 clear park light lenses.
1971-72 Chevrolet
P7172-2589-kit set 24.95



PARKLAMP WIRE GROMMETS

- Thru housing.
1947-54 Pickup
P4754-2585-HG pair 2.95

PARK LAMP ASSEMBLY

- 1947-53 Pickup
Complete with turn signal 12 volt. Amber lens.
P4753-2585-AMB each 39.95
- 1947-53 Pickup (Clear glass lens)
Complete with bezel, lens, gasket, bulb & wiring.
P4753-2585-AS each 39.95
- 1947-53 Pickup
12 volt
Complete w/turn signal, clear lens, 12v.
P4753-2585-BS each 34.95
- 1954-55 Pickup
P54-2585-AS each 49.95

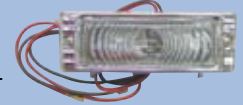
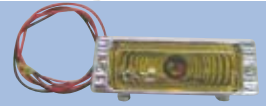

- 1954-55 (1st Series Pickup 12 volt)
Complete w/turn signal, 12 volt.
P54-2585-BS each 39.95



- 1955-57 Pickup
Complete w/ amber lens.
P5557-2585-AS each 29.95
- 1955-57 Pickup
With clear lens.
P5557-2585-BS each 29.95



- 1958-59 Pickup
Chrome plated.
P5859-2585-AS each 59.95
- 1958-59 Chevy Pickup
With clear lens. Fits LH or RH.
P5859-2585-BS each 59.95



- 1967-68 Chevy
Left hand.
P6768-2585-AL each 59.95
- 1967 68 Chevy
Right hand.
P6768-2585-AR each 59.95



- 1971-72 Chevy only all
Left hand. Includes directional signals.
P7172-2585-AL each 59.95
- 1971-72 Chevy only C10-30 All
Right hand. Includes directional signals.
P7172-2585-AR each 59.95

SHOW OFF YOUR TRUCK!

We appreciate your business!



CHASSIS & ELECTRICAL



PARK & TURN SIGNAL LAMP

Right hand
1980 Ser 10-30
P80-2585-RH each49.95

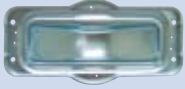

1960-66



1973-79

PARK LIGHT HOUSING

1960-66 Chevrolet Pickup
Fits left hand or right hand.
P6066-2585-H each15.95
1973-79 Ser. 10/30, Blazer, Jimmy
1980 All (exc. Chrome Grill)
Park lamp & turn signal housing.
P7380-2586-A each24.95



PARK LAMP & TURN SIGNAL BEZEL

Stainless. Fits either side.
1975-78 Ser. 10/30, Blazer, Jimmy with Special Trim
P7578-2586-A each36.95



PARKING LAMP BUMPER KIT

1971-72 Pickup
P7172-2587-BM pair1.95



AMBER PARK LIGHT BULB

1157 12v.
1954-72 All
B-2589-1157A pair2.95



HEADLIGHT AND PARKING LENS BOLT KIT

Late 1947 - Early 1955 Pickup
Stainless steel phillips oval head (like original).
P4755-2589-O kit95
1955-66 Pickup
Stainless steel phillips pan head.
P5566-2589-P kit95
1967-72 Pickup
Stainless steel phillips oval and pan head (original style).
P6772-2589-OP kit4.95

PARK LAMP LENS

1941 Chevy Pickup
Made of quality plastic with painted stripes.

P41-2589-A each56.95
1942-46 Pickup

P4246-2589-A each14.95
1947-50 GMC Pickup
Glass, requires 2.

P4750-2589-GMC each19.95
1947-53 Pickup
Glass, clear.

P4753-2589-A each7.95

1947-53 Pickup
Glass, amber.

P4753-2589-AMB each9.95
1954-55 Pickup
Amber.

P54-2589-A each8.95

1954-55 Pickup
Clear.

P5455-2589-A each8.95
1955-57 Pickup
Amber parking lamp lens.

P5557-2589-AMB each3.95

1955-57 Pickup
Clear.

P5557-2589-CA each3.95
1955-57 GMC
Left hand, clear.

P5557-2589-LH each11.95
1955-57 GMC
Right hand, clear.

P5557-2589-RH each11.95
1958-59 Pickup
Amber.

P5859-2589-AMB each8.95

1958-59 Pickup
Clear.

P5859-2589-CA each8.95

1960-66 Pickup
Clear.

P6062-2589-A each6.95

1960-66 Ser 10-30
Amber.

P6366-2589-A each6.95
1962-66 GMC
Clear.

P6266-2589-GMC pair79.95
1962-66 GMC
Amber.

P6266-2589-GMCA pair79.95

1967-68 Pickup
Clear, left hand.

P6768-2589-CL each9.95
1967-68 Pickup
Clear, right hand.

P6768-2589-CR each9.95

Park lamp lens continued...

1967-68 (Ser 10-30)
Left hand, amber
P6768-2589-A each9.95

1967-68 Chevrolet
Pickup
Amber, right hand.
P6768-2589-B each9.95

1967-72 GMC
Pickup
Same for either side.
P6772-2589-GMC each12.95
1969-70 (Ser. 10/30 (exc. D-D))
Clear, left hand.

P6970-2589-AL each9.95

1969-70 (Ser. 10/30
(exc. D-D))
Clear, right hand.

P6970-2589-AR each9.95
1971-72 (Ser. 10/30, Blazer)
Amber, left hand.

P7172-2589-AL each9.95
1971-72 (Ser. 10/30, Blazer)
Amber, right hand.

P7172-2589-AR each9.95
1971-72 Chevrolet Pickup
Clear, left hand.

P7172-2589-CL each9.95

1971-72 Chevrolet
Clear, right hand.

P7172-2589-CR each9.95
1973-74 (Ser. 10/30, Blazer, Jimmy (exc. body
side moldings. Cheyenne, Sierra)
Left hand.

P7374-2589-LH each26.95
1973-74 (Ser. 10/30, Blazer, Jimmy (exc. body
side moldings., Cheyenne, Sierra)
Right hand.

P7374-2589-RH each26.95
1973-74 (Ser. 10/30, Blazer, Jimmy with side
mouldings Cheyenne, Sierra)
Right hand.

P7374-2589-RHM each31.95
1975-78 (Ser. 10/30, Blazer, Jimmy with body
side moulding)
Left hand.

P7578-2589-LHM each31.95
1975-78 (Ser. 10/30, Blazer, Jimmy with body
side moulding)
Right hand.

P7578-2589-RHM each31.95
1975-79 (Ser. 10/30, Blazer, Jimmy (exc. body
side moldings)
1980 All (exc. Chrome Grill)
Left hand.

P7580-2589-LH each26.95

We appreciate your business!

CHASSIS & ELECTRICAL



1940 Pickup 1947-53 Pickup 1960-66 Pickup

PARKLAMP LENS GASKETS

1940 Pickup	
P40-2590-A pair	2.95
1941 Pickup	
P41-2590-A pair	3.95
1942-46 Pickup	
P4246-2590-A pair	2.95
1947-50 GMC Pickup	
P4750-2590-GMC pair	2.95
1947-53 Pickup	
P4753-2590-A pair	1.95
1951-53 GMC Pickup	
P5153-2590-GMC pair	2.95
1954-55 Pickup	
P5455-2590-A pair	2.95
1955-57 Pickup	
P5557-2590-A pair	1.95
1955-57 GMC Truck	
P5557-2590-GMC pair	3.95
1958-59 Pickup	
P5859-2590-A pair	1.95
1958-59 GMC Truck	
P5859-2590-GMC pair	9.95
1960-66 Pickup	
P6066-2590-A pair	1.95
1962-66 GMC	
P6266-2590-GMC pair	7.95
1967-68 Pickup	
P6768-2590-A set	2.95
1969-70 Pickup	
P6970-2590-A set	2.95
1972-72 Pickup	
P7172-2590-A set	1.95
1973-79 (100/300, Blazer, Jimmy)	
1980 All (exc. Chrome Grill)	
P7380-2590-A each	19.95

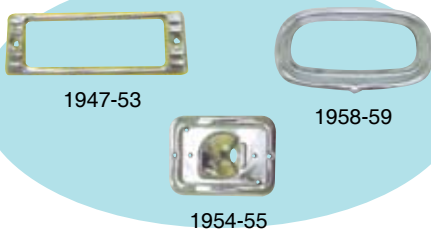

1947-53 1958-59 1954-55

PARKLAMP RIM

1947-53 Pickup	
Chrome.	
P4753-2593-A each	12.95
1954-55 Pickup	
Die cast chrome plated.	
P5455-2593-A each	29.95
1958-59 Pickup	
Fits left hand or right hand side.	
P5859-2593-A each	39.95
1962-66 All body styles	
P6266-2593-A each	16.95



PARKLAMP RIM SCREWS

1947-53 Pickup	
P4753-2593-MB set	1.95



PARKING LENS SCREW SET

Does both sides.	
1960-66 Pickup	
P6066-2594-SC set	1.95
1964-66 Pickup	
P6466-2594-SC set	3.95
1967-70 Pickup	
P6770-2594-SC set	2.95
1971-72 Pickup	
P7172-2594-SC set	2.95



PARKING & DIRECTIONAL SIGNAL LAMP LENS SCREW

1973-79 Ser. 10/30 - Cargo Lamp Lens Screw	
F6869-2594-A each	4.95



PARKLAMP BODY GASKET

1940 Pickup	
P40-2599-BG pair	2.95
1941 Pickup	
P41-2599-BG pair	5.95
1942-46 Pickup	
P4246-2599-BG pair	5.95
1947-50 GMC Pickup	
P4750-2599-GMC pair	3.95
1951-53 GMC Pickup	
P5153-2599-AS pair	6.95
1954 Pickup	
P54-2599-BG pair	5.95
1955-57 Pickup (2nd Series)	
P5557-2599-BG pair	2.95



TAIL LAMP MOUNTING GASKET

1955-59 Panel	
P5559-2660-AS pair	7.95
1973-84 Ser 10-30 Suburban	
P7384-2660-A each	5.95



1940-46 1940-53 1947-53

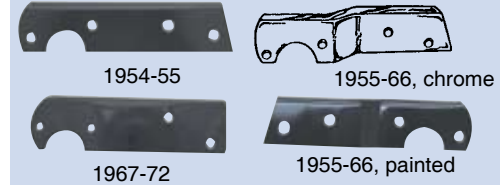

1954-55 1955-66, chrome 1955-66, painted 1967-72

TAIL LAMP BRACKET

1934-39 Pickup	
Left hand, black	
P3439-2662-AL each	39.95
1934-39 Pickup	
Right hand, black	
P3439-2662-AR each	39.95
1940-46 Pickup	
Left hand, black	
P4046-2662-AL each	29.95
1940-46 Pickup	
Right hand, black	
P4046-2662-AR each	28.95
1940-53 Pickup	
Left hand chrome plated	
P4753-2662-CHL each	12.95
1940-53 Pickup	
Right hand, chrome	
P4753-2662-CHR each	12.95
1947-53 Pickup	
Left hand, black	
P4753-2662-LPNT each	9.95
1947-53 Pickup	
Right hand, painted	
P4753-2662-RPNT each	9.95
1954-55 Pickup	
Left hand, chrome	
P54-2662-CHL each	9.95
1954-55 Pickup	
Right hand, chrome	
P54-2662-CHR each	9.95
1954-55 Pickup	
Left hand, painted	
P5455-2662-LPNT each	7.95
1954-55 Pickup	
Right hand, painted	
P5455-2662-RPNT each	7.95
1955-66 Pickup	
Left hand, chrome plated	
P5559-2662-CL each	9.95
1955-66 Pickup	
Right hand, chrome plated	
P5559-2662-CR each	9.95
1955-66 Pickup	
Left hand painted	
P5559-2662-PL each	7.95
1955-66 Pickup	
Right hand painted	
P5559-2662-PR each	7.95
1967-72 Pickup	
Left hand, stepside (painted black)	
P6772-2662-AL each	15.95
1967-72 Pickup	
Right hand stepside (painted black)	
P6772-2662-AR each	15.95



CHASSIS & ELECTRICAL

TAIL LAMP ASSEMBLY

1934-39 Chevy (W/ red glass lens)

P3439-2679-AS each**99.95**

1940-53 Pickup

Painted, right hand, complete with turn signal capability.

P4753-2679-AS each**24.95**

1940-53 Pickup

Painted, left hand, complete with turn signal capability.

P4753-2679-BS each**24.95**

1947-53 Pickup (Chrome, left hand)

P4753-2679-CLS each**29.95**

1947-53 Pickup (Chrome, right hand)

P4753-2679-CRS each**29.95**

1954-66 Pickup

Chrome tail lamp assembly, replacement style.

P54-2679-AS each**31.95**

1954-66 Pickup (Black w/stainless steel bezel)

P5455-2679-B each**34.95**

1955-59 Pickup

Original style, black with stainless steel bezel.

P5559-2679-OP each**34.95**

1955-59 Pickup (Stainless steel. Original style)

P5559-2679-SS each**39.95**

1960-66 Pickup (Black)

P6066-2679-BS each**34.95**

1960-66 Pickup (Stainless steel)

P6066-2679-CS each**39.95**

1967-72 Stepside Pickup (Stainless steel)

P6772-2679-SS each**59.95**

1967-72 Stepside Pickup

P6773-2679-AS each**49.95**

1979-84 Ser.10,30 (Left hand)

P7984-2679-LH each**24.95**

1979-84 (100/300) (Right hand)

P7984-2679-RH each**24.95**



1960-66



1973-87

TAIL LAMP HOUSING

1960-66 Fleetside Pickups
Stop, tail, turn, back-up lamp lens housing.

P6066-2680-A each**26.95**

1973-87 Chevy/GMC Pickup

1973-91 Blazer, Jimmy, Suburban
Left hand

P7391-2680-LH each**24.95**

1973-87 Pickup

Left hand, w/out trim.

P7391-2680/2-LH each**39.95**

1973-87 Pickup

1973-91 Blazer, Jimmy, Suburban
Left hand, w/trim.

P7391-2680/2-LHM each**49.95**

1973-87 Chevy /GMC Pickup

1973-91 Blazer, Jimmy, Suburban
Right hand

P7391-2680-RH each**24.95**

1973-87 Pickup

1973-91 Blazer, Jimmy, Suburban
Right hand, w/out trim.

P7391-2680/2-RH each**39.95**

1973-87 Pickup

1973-91 Blazer, Jimmy, Suburban
Right hand, w/trim.

P7391-2680/2-RHM each**49.95**



TAIL LAMP BEZEL CLIP SET

Does both sides.

1967-68 Pickup

P6768-2680-A set**7.95**

1969-72 Pickup

P6972-2680-A set**9.95**



1934-39



1940-53



1955-59



1954-55



1958-59



1960-66



1967-68



1969-72

TAIL LAMP RING/BEZEL

1934-39 Pickup

Black

P3439-2681-AB each**17.95**

1940-53 Pickup

Chrome

P4053-2681-A each**7.95**

1947-55 Panel

Chromed oval as original.

P4755-2681-A each**16.95**

1954-55 1st Ser. Pickup

Chrome

P5455-2681-A each**7.95**

1955-59 Chevy

Stainless steel

P5559-2681-AS each**4.95**

1958-59 Fleetside Pickup

Aluminum, requires 2.

P5859-2681-B each**14.95**

1960-66 Fleetside

Aluminum, requires 2.

P6066-2681-A each**16.95**

1967-68 Chevy Pickup

Left hand

P6768-2681-AL each**23.95**

1967-68 Chevy Pickup

Right hand

P6768-2681-AR each**23.95**

1969-72 Fleetside, Blazer

Polished aluminum finish, left hand.

P6972-2681-AL each**16.95**

1969 72 Fleetside, Blazer

Polished aluminum finish, right hand.

P6972-2681-AR each**16.95**



GLASS BLUE DOT

With chrome plated rim. Installs in any tail light lens.

U-2682-GBD each**3.95**

www.classicchevroletparts.com

CHASSIS & ELECTRICAL



TAIL LAMP LENS

1934-39 Chevy (Red glass)

P3439-2682-B each12.95

1947-53 Pickup (Glass lens without blue dot)

P4753-2682-GL each6.95

1947-53 Pickup (Plastic lens)

P4753-2682-PL each7.95

1947-56 Panel, Suburban
Red glass lens, w/out blue dot.

P4754-2682-A each9.95

1954-55 Pickup (Plastic lens)

P5455-2682-A each9.95

1955-58 Pickup
Cameo lens, (red plastic lens),
requires 2.

P5558-2682-CR each9.95

1954-59 Pickup (Plastic)

P5559-2682-A each4.95

1955-59 Panel delivery

P5559-2682-B each12.95

1958-59 Pickup (Plastic)

P5859-2682-A each6.95

1960-66 Fleetside (Plastic lens)

P6066-2682-AS each7.95

1960-66 Stepside (Plastic, 3
1/2" diameter)

P6066-2682-B each5.95

1960-66 Suburban

P6066-2682-C pair39.95

1965-72 All wideside (With directional signal)

P6572-2682-AS each7.95

1967-72 (100/300 Fleetside, Blazer)
Plastic, with directional signal.

P6772-2682-AS each12.95

1967-72 Stepside Pickup

P6772-2682-BS each6.95

1967-72 Chevy Pickup

Clear lens - same as "red" version.

P6772-2682-CL each9.95

1967-72 Ser. 10/20, Suburban (Red lens)

P7172-2682-AS each19.95

TAILLIGHT CENTER REFLECTOR

With original guide lettering
1955-58 Cameo only

P5558-2682-CRF each12.95

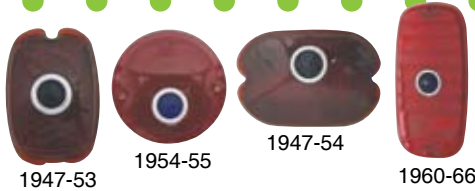

TAIL LAMP LENS WITH BLUE DOT

1947-53 Pickup (Glass with blue dot installed)

P4753-2682-BD each12.95

1947-54 Panel, Suburban

Glass lens with blue dot installed.

P4754-2682-BD each16.95

1954-55 Pickup (Blue dot tail lamp lens)

P5455-2682-BD each12.95

1960-66 Pickup (Blue dot tail lamp lens)

P6066-2682-BD each15.95

1967-72 Pickup (Blue dot tail lamp lens)

P6772-2682-BD each19.95



CLEAR TAIL LIGHT CONVERSION KIT FOR FLEETSIDE

For fleetside

1967-72 Chevy and GMC Pickup

P6772-2682-kit kit24.95

TAIL & STOP LAMP LENS

1973-84 Ser. 10/30 Fleetside,
wideside (exc. body moldings.)

1973-84 (Ser. 10/20, Suburban,
Blazer, Jimmy (exc. body mldg)

Left hand

P7384-2682-LH each19.95

1973-84 Ser. 10/30 Fleetside, wideside (exc.
body moldings.)

1973-84 Ser. 10/20, Suburban, Blazer, Jimmy

(exc. body moulding)

Right hand

P7384-2682-RH each19.95

1973-84 Ser. 10/30, Blazer,
Jimmy with body moldings.

Left hand

P7384-2682-LHM each24.95

1973-84 Ser. 10/30, Blazer, Jimmy with Body

Mouldings)

Right hand

P7384-2682-RHM each24.95

1973-93 Chevy Stepside, GMC Fenderside

Pickup

Combo, fits either side

P7393-2682-A each11.95

12V RED TAIL LAMP BULBS

#1157, sold in pairs.

B-2683-R pair3.95



1955-59



1967-72

TAIL LIGHT LENS GASKET

1934-39 Pickup

P3439-2684-A each4.95

1947-53 Pickup

P4753-2684-A each95

1947-55 Panel, Suburban

P4755-2684-AS each1.95

1954-59 Pickup

P54-2684-A each95

1955-58 Pickup (Cameo Only)

Cameo gasket (made of closed cell foam).

P5558-2684-CAM each5.95

1955-59 Panel

P5559-2684-AS each1.95

1955-59 Panel/Suburban

P5559-2684-BG pair7.95

1958-59 Pickup (Fleetside)

P5859-2684-AS each1.95

1960-66 Pickup

P6066-2684-AS pair1.95

1960-66 Pickup

P6066-2684-BS each2.95

1960-66 Panel, Suburban

P6066-2684-CS each3.95

1967-72 Pickup

P6772-2684-AS set6.95

1967-72 Pickup

P6772-2684-BS each1.95

1967-72 Stepside Pickup

P6772-2684-CS pair2.95

1973-76 Ser. 10/30 CAB - (exc. Fleetside,

Wideside)

With turn signal

P7376-2684-A each8.95

1979-84 Ser. 10/30

P7984-2684-A each23.95



TAILLIGHT LENS SCREW SET

Does both sides, replacement type.

1955-59 Pickup

P5559-2688-SC set1.95

1960-66 Pickup

P6066-2688-SC set2.95

1967-72 Pickup

P6772-2688-SC set2.95

SHOW OFF YOUR TRUCK!



CHASSIS & ELECTRICAL



TAILIGHT WIRE CONDUIT

Stainless steel tailight wire cover conduit.
1947-72 Pickup

P4772-2694-A set.....15.95

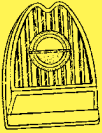

1955-58



1966-77

BACK-UP LAMP LENS

1955-58 Pickup
Cameo back-up lens, clear plastic lens with
"guide" script.

P5558-2697-CC each.....9.95

1960-66 All
Clear glass, left or right hand.

P6066-2697-LAS each.....6.95

1966-77 Pickup

P6672-2697-LAS each.....7.95

1967-72 Fleetside, Blazer
Left hand

P6772-2697-LAS each.....8.95

1967-72 Fleetside, Blazer
Right hand

P6772-2697-LBS each.....8.95

1967-72 Chevrolet/ GMC Suburban
Clear, fits left or right hand

P6772-2697-SB each.....9.95



P6772-2697-AS

BACK UP LAMP LENS GASKETS

1960-66 Fleetside

P6066-2697-AS each.....2.95

1967-72 Pickup

P6772-2697-AS set.....2.95

1967-72 Suburban

P6772-2697-BG each.....4.95

1967-72 Suburban

P6772-2697-BS pair.....4.95



Classic Chevrolet Parts
has been serving you
for over 12 years!



1967-72



1960-65



1967-68

BACK UP LAMP ASSEMBLY

Complete with lens and chrome bezel. .

1960-65 Pickup Single unit

1966 Ser. 10-20 Fleetside

1971-72 Ser. 10 D-D

Fits left or
right hand

P6072-2697-AS each.....39.95

1967-72 Suburban

P6772-2697-A kit.....19.95

1967-68 Pickup Stepside - stake rack

1975-77 Ser. 10/30 CAB

1969-72 Pickup (exc. Fleetside)

P6772-2697-AE each.....29.95



CARGO LIGHT INNER GASKET

1967-72 Pickup

P6772-2697-IG each.....3.95



BACKUP LIGHT BRACKET

1967-72 Stepside Truck

P6772-2697-LB each.....15.95



BACK UP LENS SCREW SET

Does both sides, replacement type.

1967-72 Pickup

P6772-2697-SC set.....2.95



BACK-UP SOCKET ASSEMBLY.

1973-74 (Ser. 10/30, Fleetside, Wideside)

1979-84 All w/ 8ft bed

F6974-2697-A each.....18.95



1967-72



1970

NEUTRAL SAFETY/BACK UP SWITCH

Exact replacement.

1967-72 Pickup

P6772-2698-A each.....11.95

1970 Blazer

P7072-2698-A each.....24.95

1973-75 (100/300 with A/T)

P7375-2698-A each.....29.95

1973-78 (Ser.10/30, Blazer, Jimmy with 4 spd)

1979-80 All with M/T M20

P7380-2698-B each.....16.95

1973-78 (Ser.10/30, Blazer, Jimmy with 3 spd.)

1973-84 (Ser.10/20 with M/T 3 spd)

P7384-2698-A each.....14.95

1974-79 (100/300, Blazer with 3, 4 Spd)

P7479-2698-A each.....13.95

1976-80 Pickup, Blazer with A/T

P7680-2698-A each.....27.95



*Find these great
items on page 14!*

**Classic Chevrolet
Parts knows
cars & Trucks!**



HEADLAMP WIRE GROMMET

- 1947-59 Pickup
Through housing.
P4754-2700-HG pair 5.95
1947-59 Pickup
Through inner fender.
P4754-2700-IFG pair 2.95

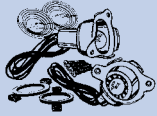

CAMEO LICENSE LIGHTS

- 1955-58 Cameo Pickup
P5558-2700-C each 59.95



HEADLIGHT ADJUSTING SCREW & NUT ASSEMBLY

- 1962-72 Chevy Pickup
P6272-2700-C each 1.95



REAR LICENSE LAMP ASSEMBLY

- 1967-72 Ser. 10-30 with rear bumper
1973-78 Ser. 100/300 with Rear Bumper, (exc. Step Bumper)
1979-81 All (exc. Step Bumper)
1979-81 Ser. 10/20, Jimmy, Blazer, Suburban
P6772-2700-A each 29.95



REAR LICENSE LAMP COVER

- 1960-72 All
P6072-2706-A each 5.95



LICENSE LAMP/LENS SCREWS

- Mounts lamp assembly and lens.
1967-72 Pickup
P6772-2708-SC set 2.95
1974-80 Pickup
1979 Pickup
1979-80 Pickup, Suburban
1980-84 Step Bumper
Oval (8 15/32")
P7484-2708-A each 1.95



LICENSE LAMP LENS GASKET

- 1947-53 Pickup
P4753-2707-G each 1.95
1947-54 Panel, Suburban
P4754-2707-AS each 1.95
1954-59 Pickup
Center lens gasket.
P54-2707-G each 1.95
1958-59 Fleetside
1960-72 (exc. rear bumper)
1979-84 (100/300 Stepside, Fleetside (exc. bumper)
Rear lens cover gasket (cork).
P5872-2707-AS each 5.95
1967-78 All with Step Bumper
1979-80 Jimmy, Blazer, Suburban
1979-84 All with Rear Bumper
P6770-2707-AS each 5.95
1967-70 Pickup, Blazer
1970 Single Unit
1971-72 Suburban, Blazer and Pickup with rear bumper
1973-78 Blazer, Jimmy
1973-81 (10/20 with rear bumper (exc. step bumper)
Rear lens gasket.
P6772-2707-AS each 3.95



1947-53

LICENSE LAMP LENS

- Clear plastic.
1947-53 Pickup
P4753-2709-A each 4.95
1958-66 Fleetside
1962-72 (100/300, Blazer without Rear Bumper)
1973-78 (100/300 (exc. Rear Bumper)
1979-84 All without Rear Bumper
P5872-2709-AS each 4.95
1967-72 (100/300, Blazer with Rear Step Bumper)
1979-80 All with Step Bumper
1979-84 (100/300 with Step Bumper)
Rear lens.
P6772-2709-AS each 7.95
1967-70 (100/300, Blazer without chrome or painted Bumper)
1970 (100/200 single unit)
1971-72 Suburban, Blazer & Pickup with Rear Bumper
1973-81 (100/300 with Rear Bumper (exc. Step Bumper)
1973-81 Blazer, Jimmy
Rear lens.
P6772-2709-BS each 6.95

check us out at
www.classicchevroletparts.com



HEADLAMP BODY MOUNT GASKET

- 1941-46 Pickup
P4146-2722-A pair 4.95
Bucket to fender.
1947-59 Pickup
P4754-2722-A pair 3.95



HEADLAMP ASSEMBLY

- 1963-68 (exc. D-Duty)
Complete with sealed beam.
P6368-2725-A each 69.95
1979-87 Pickup
Fits right or left hand, single, rectangular.
P7987-2725-R each 29.95
1979-87 Pickup
Single, rectangular, halogen.
P7987-2725-RH each 34.95



HEADLAMP REFLECTOR

- Rectangular.
1980 C, K-1, 2, 3
P80-2725-A each 69.95

1973-80



1941-55

1958-62



1980

HEADLAMP BODY INNER RING

- 1941-55 All
P4172-2726-A each 39.95
1958-62 All
P5862-2726-A each 29.95
1958-62 All
Inner left. I-2 on flange.
P5862-2726-B each 29.95
1973-80 (Ser. 10/30, Blazer, Jimmy (exc. Chrome Grill)
Fits right or left hand.
F7581-2726-A each 39.95
1980 (Ser. 10/30)
Rectangular.
P80-2726-A each 46.95



CHASSIS & ELECTRICAL



HEADLAMP ADJUSTER SCREW SET

- 1955-61 Chevy
- P5561-2726-ASSY kit. 7.95**
- 1964-66 Pickup
- Does 1 side, does not include spring.
- P6466-2726-ASSY kit. 3.95**
- 1967-72 Pickup
- P6772-2726-ASSY kit. 1.95**



1958-61



1975-78



1980

SEALED BEAM HEADLAMP

- 1958-61 All
- Inner sealed beam headlamp, single filament.
- P5861-2727-ISB each. 14.95**
- 1958-61 All
- Outer sealed beam headlamp, double filament.
- P5861-2727-OSB each. 11.95**
- 1975-78 Ser. 10/30, Blazer, Jimmy
- 1979-81 All with 2 Headlamp Sys.
- Round lbs, 7" dia.
- F6781-2727-ISB each. 11.95**
- 1980 (100/300)
- Rectangular.
- P80-2727-A each 19.95**



HEADLAMP HOUSING SCREW AND CLIP SET

- 32 pcs.
- 1947-54 Pickup
- P4754-2728-MB set 7.95**



Gotta question?
Ask Mike! He's here to help.



HEADLAMP DOOR

- 1941-46 Pickup
- Chrome plated, original type.
- P4146-2728-A each 29.95**



- 1947-54 Pickup (Polished stainless steel)
- P4754-2728-S each 14.95**



- 1955-57 Pickup (Chrome)
- P5557-2728-PR pair 109.95**



- 1958-59 Pickup (Chrome)
- P5859-2728-A pair 109.95**



- 1963 Pickup (Chrome)
- P63-2728-PR pair 59.95**



- 1964-66 Pickup (Chrome)
- P6466-2728-PR pair 59.95**



- 1967-68 Pickup (Aluminum w/ mounting screws)
- P6768-2728-PR pair 69.95**

- 1969-72 All (Aluminum. Paint as required, mounting screws included)

- P6972-2728-PR pair 22.95**

- 1967-72 GMC
- 1969-72 GMC headlamp bezels

- P6972-2728-GMC pair 124.95**

- 1973-78 (Ser. 10/30, Blazer, Jimmy)
- Left hand, with single round headlamp. Made of chrome plastic.

- P7378-2728-LH each 16.95**

- 1973-78 (Ser. 10/30, Blazer, Jimmy) (Right hand, w/ single round headlamp. Chrome plastic.)

- P7378-2728-RH each 16.95**

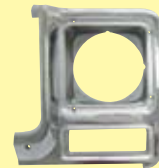

- 1979 Chevy/GMC with round headlamp
- Left hand. Chrome plated plastic. Fits early 1979.

- P79-2728-LH each 19.95**

- 1979 All with round headlamp
- Right hand. Chrome plated plastic. Fits early 1979.

- P79-2728-RH each 19.95**

- 1979-80 4wd (Ser. 10-30) (Chrome plastic with square headlamp. Fits late 1979 and all 1980)

- P7980-2728-LH each 36.95**

- 1979-80 (2&4wd, Ser. 10/30) (Left hand, argent, plastic)

- P7980-2728-LHA each 19.95**

- 1979-80 (4wd, Ser. 10-30) (Right hand, square headlamp. Fits late 1979 & all 1980. Chrome plated plastic.)

- P7980-2728-RH each 36.95**

- 1979-80 C, K-1, 2, 3 (Right hand, argent, plastic)

- P7980-2728-RHA each 19.95**

Chevy...



American Made



HEADLIGHT BEZEL SCREWS

- 1955-57 Pickup
Does both sides.
- P5557-2729-SC set**1.95
- 1960-66 GMC Pickup
Attaches both lights to grill.
- P6066-2729-SC kit**2.95
- 1962 Pickup
Does both lights.
- P62-2729-SC kit**2.95
- 1963 Pickup
- P63-2729-SC set**2.95
- 1964-66 Pickup
Does both sides.
- P6466-2729-SC set**1.95
- 1967-68 Pickup
Does both sides.
- P6768-2729-SC kit**2.95
- 1969-72 Pickup
Does both sides, includes j-nuts.
- P6972-2729-SC set**2.95
- 1973-78 (2wd, 4wd, Ser. 10-30)
Push in for .28 sq. hole.
- P7378-2729-C each**1.95



1941-55



1980

SEAL BEAM RETAINING RING

- Chrome plated one piece construction.
- 1941-55 All 6 Colt
1962-72 All & Blazer
- P4172-2731-A each**9.95
- 1958-61 All
- P5861-2731-A each**28.95
- 1973-81 (2wd, 4wd, Ser. 10-30, Blazer, Jimmy
(exc chrome grille)
2 lamp round sys.
- F7681-2731-A each**59.95
- 1980 (2wd, 4wd, Ser. 10-30)
Rectangular
- P80-2731-A each**29.95



**These colors
don't run!**



HEADLAMP RIM SEAL

- With wire core.
- 1947-56 Pickup
- P4754-2735-A pair**5.95



HEADLAMP RETAINING RING SCREW

- 1973 All, Blazer, Jimmy
- F6771-2737-A each**1.95
- 1973-77 All, Blazer, Jimmy
- 1978 (2wd, 4wd, Ser. 10-30)
- 1979-84 All
- F7681-2736-A each**1.95



HEADLAMP ADJUSTER NUT

- 1973-77 All
- 1978 (2wd, 4wd, Ser. 10-30 Blazer, Jimmy)
- 1979-80 (exc chrome grille)
- F6777-2737-A each**1.95
- 1979-80 (2wd, 4wd, Ser. 10-30 (w/ Chrome
Grill))
- P7980-2737-A each**9.95



HEADLAMP BEAM ADJUSTING SPRING

- 1973-79 2wd, 4wd, Ser. 10-30, Blazer, Jimmy
- 1980 All (exc chrome grille)
- P7380-2737-A each**4.95
- 1980-84 (2wd, 4wd, Ser. 10-30)
- P8084-2737-A each**2.95



HIGH/LOW STEEL HORN ASSEMBLY

- Exact reproduction of the GM low and high note horns. Stamped steel and painted black. Comes with universal brackets.
- 1955-87 Chevy/GMC Pickup all body styles
- B5587-2810-PR pair**119.95



HORN RELAY

- For 6 volt systems.
- 1929-54 Pickup
- P2954-2815-A each**19.95
- 1955-56 Pickup
- P5556-2815-A each**27.95
- 1957-71 Pickup
- 1957-72 GMC
- P5771-2815-A each**12.95
- 1963-65 Pickup
- 1967 Pickup
- P6367-2815-A each**29.95
- 1973-82 Ser. 10-30, Blazer, Jimmy
- F7481-2815-A each**11.95

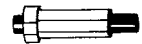

HORN CONTACT INSULATOR

- 1962 All
- P6266-2819-HI each**6.95



STANDARD HORN CAP RUBBER MOUNTING RING

- Provides interlock between horn cap and horn contact.
- 1967-68 Truck
- F6768-2819-R each**4.95



HORN BLOW CONTACT KIT

- With eyelet, spring and insulator.
- 1973-84 All, Blazer, Jimmy
- F6781-2819-A each**3.95



HORN BUTTON RETAINER

- 1947-53 Pickup
- P4753-2820-A each**19.95
- 1954-59 Pickup
- P54-2820-A each**19.95





CHASSIS & ELECTRICAL

HORN BUTTON

- 1929-40 Pickup
With rubber retainer & horn wire.
P2940-2820-A each23.95
- 1941-46 Pickup
With center threaded stud.
P4146-2820-A each29.95
- 1947-53 Pickup
Chrome with painted details.
P4753-2820-B each29.95
- 1954-55 (55 1st ser.) Chevy Pickup
Chrome with black insert.
P5455-2820-A each29.95
- 1955-56 (55 2nd ser.) Chevy
Chrome with black insert.
P5556-2820-A each29.95
- 1957-59 Chevy Pickup
Chrome with black insert.
P5759-2820-A each29.95
- 1960-66 Pickup
Bow-tie cap, w/rubber retainer,
chrome.
P6066-2820-A each39.95
- 1969-72 Pickup, Blazer,
Suburban
Blue with blue bow-tie.
P6972-2820-BL each19.95
- 1969-72 Chevy
Dark blue Chevy cap.
P6972-2820-DB each19.95
- 1969-72 Pickup, Blazer,
Suburban
Green with blue bow-tie.
P6972-2820-G each19.95
- 1969-72 Pickup, Blazer,
Suburban
Saddle with blue bow-tie.
P6972-2820-S each19.95
- 1969-72 Pickup, Blazer,
Suburban
Black with blue bow tie.
P6972-2820-BK each19.95
- 1973-77 2wd, 4wd, CK1,2,3.,
Blazer, Chevy Only
Horn button cap assembly.
P7377-2820-A each19.95
- 1978-80 Pickup
"Custom" horn cap w/cover
P7880-2820-C each29.95
- 1978-80 Pickup
"Standard" Chevrolet horn
cap base
P7880-2820-S each29.95

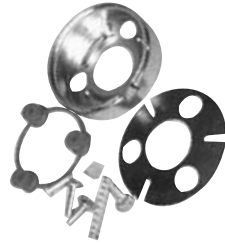

HORN CAP RETAINING KIT

- Mounts cap to wheel.
1969-72 Truck
P6972-2820-A kit23.95



BACKING LAMP SWITCH TO JUNCTION BLOCK WIRE CONNECTOR

- 1960-66 All
P6066-2892-A each24.95

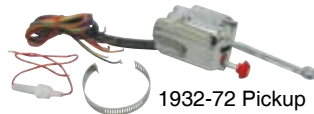

TURN SIGNAL SWITCH

- 1932-72 Pickup
Heavy duty type with emergency flasher accom-
modation. Universal turn signal indicator switch
(6 or 12 volt). Clamp to steering column.
U-2895-BS each29.95



TURN SIGNAL SWITCH

- 1955-59 Pickup
Complete with wires. Turn signal switch fits
under steering wheel and goes through steering
column.
P5559-2895-B each28.95
1960-62 All
P6062-2895-A each11.95



- 1963 All
With wiring.
P63-2895-A each59.95
1964-66 All
With wiring.
P6466-2895-A each46.95
1967-72 Pickup w/ out Tilt Wheel
With correct 1/2 moon plug, does not require an
adapter like GM's does.
P6772-2895-A each29.95
1967-72 Pickup w/ Tilt Wheel
With correct 1/2 moon plug installed.
P6772-2895-B each59.95
1973-83 (2wd, 4wd, Ser. 10-30, Blazer, Jimmy)
P7383-2895-A each46.95



NEXT DAY AIR shipping
available on any order



**Birthday
coming up?
Ask for a Classic
Chevrolet Parts
gift certificate!**





TURN SIGNAL CANCELLING PLATE

1954-59 Pickup
P5459-2895-PL each3.95
 1962-66 Pickup
P6266-2895-PL each8.95



TURN SIGNAL WEDGE

1954-59 Pickup
P5559-2895-A each2.95



TURN SIGNAL MECHANISM REPAIR KIT

Includes mechanism, spring, retainers & bushing.
 1960 Pickup
P60-2895-K kit39.95
 1961-62 Pickup
P6162-2895-K kit39.95



TURN SIGNAL CANCELLING CAM

1963 Pickup w/o tilt
P63-2895-CA each9.95
 1964-66 Pickup w/o tilt
P6466-2895-C each9.95
 1967-72 Pickup
 Repairs worn out turn signal switch. Also fits 1973-76 with tilt.
P6772-2895-CA each9.95
 1971-72 Pickup (w/tilt wheel)
A6768-2896-TC each9.95
 1973 92 Truck w/o tilt
P7392-2895-CA each8.95



TURN SIGNAL MECHANISM HOLD-DOWN BOLT W/WASHER

1960-62 Truck
P6062-2896-A each2.95

1961-72 1954-59

TURN SIGNAL KNOB

Black
 1954-59 Pickup
P5459-2897-A each9.95
 1961-72 All
P6172-2897-KNOB each3.95



TURN SIGNAL LEVER

1955-59 Pickup
 With knob.
P5559-2906-TSL each9.95
 1960 Truck
 With knob.
P60-2897-A each12.95
 1960-62 Chevrolet Pickup w/out tilt wheel
P6062-2897-A each11.95
 1963-66 Pickup w/out tilt wheel
A6466-2897-A each10.95
 1967-72 (exc. D-Duti & FFC or Cruise Control)
 With knob.
P6772-2897-A each12.95
 1968-69 All w/ Cruise Control - (exc FFC)
 1973-80 (2wd, 4wd, Ser. 10-30, w/ Speed & Cruise Control)
 1974 (2wd, Ser. 10-30, Blazer)
 1974 (2wd, 4wd, Ser. 10/20 Suburban)
 1975-77 (2wd, 4wd, Blazer)
 Original GM with switch.
P6869-2897-A each149.95
 1973-81 All, Blazer, Jimmy (exc Cruise Control)
 With knob.
F7681-2897-A each19.95

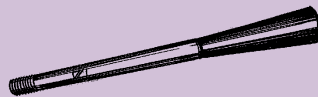

TILT RELEASE LEVER

1967-72 Chevy/GMC Pickup (also fits vans)
 With knob and tilt.
P6772-2897-RL each8.75



BILLET STEERING COLUMN KNOB KIT

Includes tilt lever, 4 way flasher knob, and gear shift knob.
 1967-72 Chevy
P6772-2897-kit kit49.95



ALCOHOL RESISTANT GAS TANK SLOSHING COMPOUND SEALER

World's No. 1 Gas Tank Sealer. Impervious to all fuel types. Over 2,000,000 sold to date. This is the best way to repair and restore your fuel tank. Simple application, includes extensive application information and product information sheet. Will seal pinhole leaks and prevent rusting. 1 Quart.
 (Replaces #A-9001-ALR)
B-3000-ALR each27.95



GAS TANK ETCH

An excellent prep for your gas tank before introducing gas tank sealer. Will remove light buildup of rust inside tank. Leaves a gray phosphate coating. 1 pint is good for about a 30 gall tank.
 (Replaces #A-9001-GTE)
B-3000-GTE each11.95





FUEL SYSTEM, EXHAUST, CARB



1949-54



1955-59



1960-66



1967-72

GAS TANKS

Original style, die stamped steel.
1949-54 (1st series, 1/2 ton Pickup)

P4954-3001-A each199.95

1955-59 Chevy

Reproduction of the original fuel tank behind the seat. Galvanized coated.

P5559-3001-A each199.95

1960-66 Chevy

Galvanized gas tank. Exact reproduction of original. Fits behind the seat.

P6066-3001-A each199.95

1967-72 Chevy

Exact reproduction of the original fuel tank behind the seat, galvanized.

P6772-3001-A each199.95

1972 Chevy Pickup

Vented with EEC galvanized steel.

P72-3001-A each199.95

1973-81 Chevy/GMC with LWB Pickup

20 galls. Fits left hand, main or right hand auxiliary tank. **Some LWB trucks require a 16 gall tank.**

P7381-3001-A each149.95

1973-81 Pickup

16 gall. Fits left hand, main or right hand auxiliary tank. May also fit some LWB Trucks, (1 1/4" i.d. small filler tube)

P7381-3001-B each149.95



BLAZER FUEL TANK

1963-72 Chevy/GMC Pickup (frame rail mount)
1967-72 Chevy/GMC Panel & Suburban
1969-72 Chevy/GMC Blazer
Replacement fuel tank, galvanized steel, frame rail mount.

P6972-3001-A each259.95

1971-72 Blazer (1969-70 w/ minor modification)

Replacement tank. Polyethylene 1 pc. tanks that are the exact same shape and size as the original. 21 galls and have almost 1/4 in. thick walls. They only weigh 12 lbs. and are not oversize so shipping is cheaper. May be put on Pickups and remove the tank from behind the seat. Measures 14" h x 26" l x 15 1/2" w.

P7172-3001-A each219.95

1973-81 Blazer, Jimmy, Suburban

31 gall, 1 1/4" i.d. small filler tube. OEM #6259406. Measures 28 1/2" x 29" x 13".

P7381-3001-C each149.95

1973-81 Blazer, Jimmy, Suburban

25 galls, 1 1/4" i.d. small filler tube. OEM #6259671. Measures 28 1/2" x 29" x 11".

P7381-3001-D each149.95



FRAME RAIL FUEL TANK KIT

Replaces factory gas tank from inside of cab. Relocates a new 21 gallon tank between frame rails. 1963-66 Chevy

Kit includes fuel tank, straps, 0-30 OHM fuel sending unit, and lock ring.

P6366-3001-kit kit249.95

1963-72 Chevy/GMC Pickup (replacement frame rail mount)

1967-72 Chevy/GMC Panel & Suburban

1969-72 Chevy/GMC Blazer

Kit includes fuel tank, straps, 0-90 OHM fuel sending unit, and lock ring.

P6972-3001-K kit299.95



1973-81

1947-48

1973-76

GAS TANK FILLER HOSE

1947-48 Ser. 20

Under right side of bed.

P4748-3003-S each9.95

1973-76 Ser. 10-30 (Stakebody, Stepside, Fenderside)

1977-78 2wd, Ser. 20/30 (Stakebody)

1977-78 2wd, Ser. 20/30

P7378-3003-B each56.95

1973-78 Ser. 10-30 (Fleetside, Wideside)

P7378-3003-D each16.95

1973-81 Ser. 10/20, Suburban, Blazer, Jimmy

P7381-3003-C each24.95

1975-78 Ser. 10-30 (Fleetside, Wideside) w/ Aux. Tank

P7578-3003-A each27.95

1975-78 Ser. 10-30 (Fleetside, Wideside) w/ Aux. Tank

P7578-3003-B each29.95

1973-74 Ser. 10 Cab

1975-79 Ser. 10-30 (Cab (exc Stepside, Fleetside, Stakebody))

P7379-3003-A each29.95

1979-80 Ser. 10-30 (Stepside)

Right hand

P7980-3003-RH each39.95

1979-81 Ser. 10-30, Fleetside

P7981-3003-A each25.95



FILLER & VENT HOSE

1948-59 Pickup

P4854-3003-A pair7.95



GAS TANK FILLER NECK HOSE CLAMP SET

1949-59 Pickup

P4959-3004-CL set6.95



FUEL SYSTEM, EXHAUST, CARB



1939-41 & 46



1947-59

GAS TANK NECK GROMMET

1939-41 & 46 Chevy/ - GMC Pickup
Rubber grommet.

P3946-3008-A each 14.95

1946 Pickup (2nd Series)
Held on with 4 screws.

P46-3008-A each 7.95

1947-48 Pickup
Fits in right hand bed side.

P4748-3008-A each 9.95

1947-55 Panel & Suburban
Rubber.

P4755-3008-A each 9.95

1947-59 Pickup

P4854-3008-A each 4.95

1960-66 Cab

P6066-3008-A each 4.95

1967-70 Chevy/GMC

P6770-3008-A each 4.95

1971-72 Chevy/GMC

P7172-3008-A each 4.95



GAS TANK FILLER KIT

Includes filler neck, filler hose, vent hose, gas cap, neck grommet, and clamps.

1947-54 Chevy

P4754-3010-kit 59.95

1955-59 Chevy

P5559-3010-kit 59.95



GAS TANK FLOOR SEAL

1949-53 Pickup

P4953-3010-A each 4.95



GAS TANK MOUNTING KIT

1932-46 Pickup

P-3015-MB each 9.95

1947-54 Pickup

P4754-3015-MB 8 pc kit. 14.95

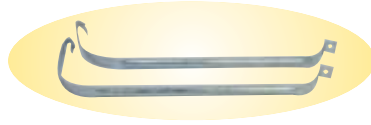

GAS TANK STRAP

Complete with hardware.
1967-72 Blazer & Suburban

P6772-3022-ST each 39.95



1931-48

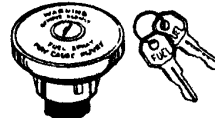

1973-74

LOCKING GAS CAP

1931-48 Pickup

With Chevrolet bow tie on flipper lid covering lock hole.

P3148-3028-BTS each 49.95

1937-68 Pickup, Blazer, Suburban

Chrome, aftermarket. Complete with keys.

P3768-3028-BL each 19.95

1937-70 (exc 1970 Calif Models)

1971-72 (Over 6000 #GVW, exc Calif)

P3772-3028-B each 12.95

1947-54 Pickup

Original style.

P4754-3028-AL each 59.95

1955-66 Pickup

Smooth, chrome.

P5566-3028-LSC each 8.95

1971 (Under 6000 #GVW)

P71-3028-C each 19.95

1971 Pickup

P71-3028-L each 19.95

1972-74 Ser. 10, Stepside

1973-74 Ser. 20/30 (Stepside - Calif, Models Only)

1975-78 Ser. 10-30, Stepside

F7174-3028-BS each 14.95

1973-74 Ser. 20/30, Stepside, Fleetside (exc Calif. models)

F6970-3028-BS each 14.95

1973-74 Ser. 20/30, Fleetside (Calif Models Only)

1973-74 Ser. 10, Fleetside

1973-74 Ser. 10, Blazer, Suburban

1975-78 Ser. 10/20, Blazer, Suburban

1975-78 Ser. 10-30, Fleetside

P7378-3028-B each 19.95

1979-84 Ser. 10/20, Blazer, Suburban

1979-94 Ser. 10-30

F7581-3028-BS each 14.95



1954-72



1937-70



1973-74

NON-LOCKING GAS CAP

1937-70 Pickup, Blazer, Suburban

1971-72 (over 6000 #GVW - exc Calif models)

P6970-3028-A each 5.95

1954-72 All

1973-74 2wd, Ser. 10 (Cab) L.P. Gas w/ wood-grain ext.

Includes gasket. Paint as required.

P5472-3028-A each 32.95

1971 Pickup

P71-3028-B each 9.95

1972 Ser. 10/20, Blazer, Suburban

1973-74 Ser. 20/30, Stepside, Calif

1975-78 Ser. 10/30, Stepside

P72-3028-A each 9.95

1973-74 Ser. 20/30, Stepside, (exc Calif Models)

P7374-3028-A each 5.95

1973-74 Ser. 20/30, Fleetside (exc Calif Models)

P7374-3028-B each 9.95

1973-74 Ser. 10, Blazer, Suburban

1973-74 2wd, Ser. 20/30, Fleetside (Calif Models Only)

1973-74 Ser. 10, Fleetside

1975-78 Ser. 10-30, Fleetside, Gas,

1976 Ser. 10-30, Fleetside

1976-78 Ser. 10/20, Suburban, Blazer, Jimmy (exc woodgrain exterior)

1976-77 Ser. 10-30, Fleetside, Wideside

1978 Ser. 10-30

P7378-3028-A each 9.95

1979-94 Ser. 10/20, Blazer, Suburban

1979-94 Ser. 10-30, Pickup

F7581-3028-AS each 6.95



FUEL GAUGE RESISTOR

Protects 6 volt fuel gauges when changing from 6 volt to 12 volt charging system.

P-3107-A each 13.95

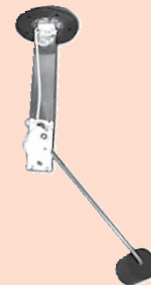

GAS TANK SENDING UNIT

Includes float and gasket.

1947-53 Chevy (6v)

P4753-3107-A each 44.95

1954 Pickup (but will work on 1948-53) (6v)

1955-59 (2nd Series (exc. Panel) (6v)

P54-3107-A each 59.95

We appreciate your business!



FUEL SYSTEM, EXHAUST, CARB

Gas Tank Sending Units

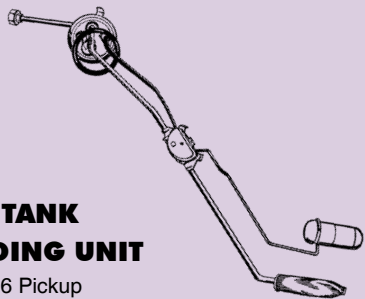

GAS TANK SENDING UNIT

1960-66 Pickup
With gasket. 12 volt

P6066-3107-A each59.95

1967 Pickup

1968-71 Pickup (exc 327, 350, 396)

With gasket and sock filter. For 6 cyl engines.
12 volt

P6771-3107-A each69.95

1968-71 (327, 350, 396)

1969-71 Blazer (350)

1972 Suburban (350, 400, exc 4wd, A/T)

1972 Suburban & Blazer, (4wd)

1972 Suburban (307, exc 4wd)

With gasket.

P6872-3107-A each69.95

1969-71 Pickup with 4B, Carb (350, 396, 400)

With sock filter and gasket. For 8 cyl engines.

P6971-3107-A each59.95

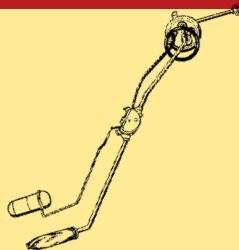

1973-74 Ser.10/20 Suburb AT w/4BC 350 (exc 31 & 40 gall tank)

1973-74 Ser.10/20 Suburb 454 (exc 31 & 40 gal tank)

1975-77 2wd, 20/30 w/ 25 gall tank 454

1975-77 Suburb 4wd, w/AT, 400 (exc 31 & 40 gall tank)

1975-77 Suburb, Blazer, Jimmy w/AT 8 Cyl (exc 31 & 40 gall tank)

4 outlets

P7377-3107-B each239.95

1973 2wd, Ser. 20 Suburban w/ 31, gall tank (exc AT)

3 outlets

P7377-3107-C each69.95

1973-77 Ser. 10/20 Suburban w/ 40 & 31 gall. tank 454

1973-77 Ser. 10/20 Suburban AT w/ 21 & 40 gall tank

305, 350, 400

4 outlets

P7377-3107-D each69.95

1973-75 2wd, Ser. 20-30 Cab w/E.E.S 250, 292, 307, 350

1973-75 4wd, Ser. 10 Cab

1973-75 4wd, Ser. 20 Cab w/ E.E.S 250, 292, 307, 350

1973-75 2wd, Ser.20/30 Cab 292, 350 (exc 25 gall tank)

1973-77 2wd Cab w/ H.D. Chassis 250, 305, 307, 350

(exc L.P. Gas)

1976-77 4wd, Ser. 10-30 Cab 250, 292

1976-77 4wd, Ser. 10-30, Cab 350 exc AT

1977 2wd, Ser. 10 Cab 250, 305, 350 (exc H.D. Chassis)

1978 2wd, Ser.10 (03) 292, 350 w/H.D. Susp (exc Calif)

1978 2wd, Ser. 20 (03) 292, 350 (exc Calif, rear tank)

2 outlets

P7379-3107-E each129.95

1973-74 2wd, Ser. 10 Cab w/ Aux Tank 250, 307, 350

1973-74 2wd, Ser. 20/30 Cab E.E.S. w/Aux Tank 292, 307, 350

1973-74 4wd, Ser. 10/20 Cab E.E.S w/ Aux Tank

1975 2wd, Ser. 10 Cab w/Aux Tank 350 (exc 117.5 W.B.)

1976-77 2wd, Ser. 10-30 Cab w/ Aux Tank 292, 350

1976-77 4wd, Ser. 10/20, Cab w/ Aux Tank 350 (exc AT)

1976-77 4wd, Ser. 20 Cab w/ Aux Tank 292

1977 4wd, Ser. 30 w/ Aux Tank

1978 2wd, Ser. 10 250, 350 w/ Aux Fuel tank, H.D.

Susp (exc Calif)

1978 2wd, Ser. 20 (292, 350) w/ Aux Tank (exc Calif)

2 outlets

P7379-3107-F each79.95

1973-74 2wd, Ser. 10-30, Cab E.E.S w/ Aux Tank 454

(exc 117.5" W.B.)

1975 2wd, Ser. 20/30 Fleetside 454

1975 4wd, Ser. 10/20, Fleetside, Wideside w/ AT 350

1976-77 2wd, Ser. 10-30, Cab w/ Aux Tank 454

1976-77 4wd, Ser. 10/20 Cab Aux Tank w/ AT 350, 400

1977 2wd, Ser. 10 Cab w/Aux Tank 454 (exc H.D. Chassis)

1978 2wd, Ser. 10-30 (454) w/ Aux Fuel Tank (exc Calif)

1978 4wd, Ser. 10-30 (400) w/ AT Fuel Tank (exc Calif)

1978 4wd, Ser. 10-30 (350) w/ AT, Aux Fuel Tank

1979 Ser. 30 (454, 400) w/ Aux Tank (exc Calif)

3 outlets

P7379-3107-G each119.95

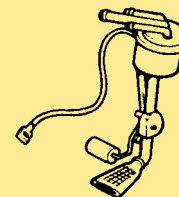

1973 2wd, Ser. 10-30 Cab AT w/ E.E.S 350

1973-75 2wd, Ser. 10-30 Cab w/ E.E.S. 54

1975-77 2wd, Ser. 10 Cab w/ H.D. Chassis 454

1975-77 2wd, Ser. 20/30 Cab exc 25 gall tank

1975-77 4wd, Ser. 10-30 Cab w/ A.T. 350, 400

1977 2wd, Ser. 10 Cab 454, (exc H.D. Chassis)

1978 2wd, Ser.10-30 (454) w/H.D. (exc Calif) rear mnt tank

1978 2wd, Ser. 20 (454)

1978 2wd (309, 314 (exc Calif)

1978 4wd, Ser. 10-30 (350) w/ AT (exc Calif)

3 outlets

P7379-3107-H each119.95

1978 Ser. 10/20 (350) w/ AT (exc 31 & 41 gall Calif)

1978 Ser. 10/20 (400, 545 (exc 31 & 41 gall Calif)

1978 2wd, Ser. 20/30, (454 with rear mounted tank)

1978 2wd, Ser.10/20 (454) w/ Calif (exc 31 or 40 gall tank)

1978 Ser. 10/20 (350) Calif (exc 31 or 40 gall tank)

1978 2wd, Ser.20/30 (454) w/ Calif, rear mount tank

1978 4wd, Ser.10 (350) w/AT, Calif (exc 31 or 40 gall tank)

1979 Ser.10/20, Blazer, Jimmy 305, 350 w/AT, 20 gall tank

1979 Ser. 10/20 Suburban, Jimmy 400, 454 w/ 20 gall tank

1979 Ser. 20/30 (2 dr) 350, w/ AT rear mnt tank 2 dr 454

P7880-3107-A each149.95

1978 Ser. 10/20 w/ AT, 31 & 40 gall tank (exc Calif)

1978 Ser. 10/20 (400, 454) w/ 31 & 40 gall (exc Calif)

1978 Ser. 10/20 w/ AT, Calif, 31 or 40 gall tank

1978 Ser. 10/20 (400, 454) w/ Calif, 31 or 40 gall tank

1978 4wd, Ser. 10 (400, 454) w/ 31 or 40 gall tank

1978 4wd, Ser. 10 (350 w/ AT, Calif) 31 or 40 gall tank

1979 Jimmy Blazer, Suburb 305, 350 w/AT, 31 or 40

gall tank

1979 Ser.10/20 Suburb, Jimmy, Blazer 400, 454 w/ 31

or 40 gall tank

1980 Ser.10/20 Suburb, Blazer, Jimmy 400, 454 gall tank

P7880-3107-B each159.95

1978 2wd, 4wd, w/ MT, Calif, 31 or 50 gall tank

1978 2wd, Ser. 10, (350) w/ Calif, 31 gall tank, 2wd,

200 (350 w/Calif, 21 or 40 gall tank)

1978 4wd, Ser. 10 (350) w/ MT, Calif, 31 gall tank

1979 Ser. 10 Suburb, Jimmy, Blazer 250, 40 gall tank

1979 Ser. 10/20 Suburb, Jimmy, Blazer 305, 350 w/MT

40 & 31 gall tank

1980 Ser.10/20 Suburb, Blazer, Jimmy 305, 350 w/31

gall tank

1980 2wd, Ser.20, Suburb 350 w/MT (M20) Calif gas tank

1980-81 Ser.10, Suburb, Blazer, Jimmy 250 w/ 31 gall tank

P7880-3107-C each159.95

1979 Ser.10, Suburb, Blazer, Jimmy 250 w/20 gall tank

1979 Ser.10/20, Suburb, Blazer, Jimmy 305, 350 w/MT

20 gall tank

1979 Ser. 20/30 (350) w/ MT, rear mounted tank

1979 Ser. 20/30 (250, 292) w/ rear mounted tank

1980 Ser. 10 (250), 2wd, 4wd, 100 (305, 350) w/ MT

1980 Ser. 20/30 w/ MT, rear mounted tank

1980 Ser. 20/30 (6 Cyl) w/ rear mounted tank

P7980-3107-A each159.95

More gas tank sending units on the next page....

FUEL SYSTEM, EXHAUST, CARB



Continued from previous page....

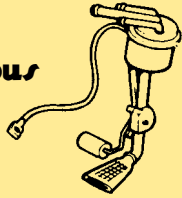

- 1980 Ser. 10/20 Suburban with 40 gall tank
P80-3107-A each159.95
- 1980 2wd, 4wd, (250)
- 1980 2wd, Ser. 20 (250) exc rear mounted tank
- 1980 2wd, Ser. 20, 4dr
P80-3107-B each129.95
- 1980 Ser. 10 (305,350 (exc Diesel)
- 1980 Ser. 20 (350 (exc rear mounted tank)
- 1980 2wd, Ser. 20 (350, H.D., 454 H.D. (exc rear mounted tank)
P80-3107-C each129.95
- 1980 Ser. 10/20 (250) w/ Aux Tank
- 1980 Ser. 20/30 (292) w/ Aux Tank
P80-3107-D each129.95
- 1980 Ser. 10/20 (305, 350) w/ Aux Tank (exc Diesel)
- 1980 2wd, Ser. 20/30 (350, H.D., 454, H.D.) w/Aux tank
P80-3107-E each129.95



GAS TANK SENDER GASKET

- 1947-59 Pickup
P4754-3107-A each1.95

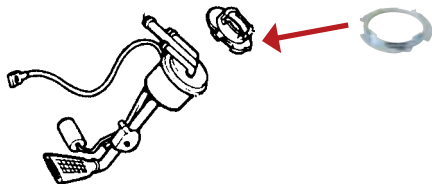

GAS TANK SENDING UNIT LOCK RING

- Fuel sender locking ring.
- 1969-72 Pickup
F6781-3107-A each1.95
- 1973 Ser.10-30
- 1974-78 All, Blazer, Jimmy
P7378-3107-CAM each6.95



FUEL SENDER SCREW KIT

- Fuel tank sending unit mount screws, 10 pieces.
- 1947-66 Pickup
P4766-3107-KIT1.95



INSTRUMENT PANEL FUEL GAUGES



- 1947-49 Chevy PU
12 volt with red needle.
P4749-3108-12 each59.95
- 1947-49 Chevy Pickup
6 volt with red needle.
P4749-3108-6 each59.95



- 1950-53 Chevy Pickup.
6 volt with white needle.
P5053-3108-6 each59.95



- 1950-53 Chevy Pickup
12 volt with white needle.
P5053-3108-12 each59.95



- 1955-59 Chevy
P5559-3108-A each74.95



- 1967-69 (exc. D-Duti)
- 1970-72 All & Blazer (exc FFC & D-Duti)
P6772-3108-A each39.95



FUEL TANK FILTER

- In tank.
- 1974-76 Ser. 10-30 Cab
- 1974-76 Ser. 10/20 Suburban, Blazer, Jimmy
- 1977 2wd, Ser. 10 Cab
- 1978 Ser. 10-30 w/ Aux, Fuel Tank
- 1978 Ser. 10-30 (exc Rear Fuel Tank)
- 1979-81 Ser. 10/20 (2dr, 4dr)
- 1979-81 Ser. 30
P7481-3110-A each12.95
- 1978 Ser. 10-30
- 1978 Ser. 20/30 w/ rear mounted fuel tank
- 1979-81 Ser. 10-30 Suburban, Blazer, Jimmy
P7881-3110-A each10.95



1934-36



1947-72

GAS TANK FLOAT

- 1934-36 Pickup
Cork material as original.
P3436-3112-A pair3.95
- 1947-72 Pickup
Brass as original.
P4772-3112-A each8.95

- 1976 2wd, Ser. 10 Cab w/ H.D. Chassis (exc tach) 1st Design
- 1976 2wd, Ser. 10 Suburban, Blazer, Jimmy (exc tach, 1st Design)
- 1976 2wd, Ser. 20/30, (exc tach) 1st Design
- 1976 4wd, Ser. 10/20, Blazer, Jimmy (exc tach) 1st Design

W/ resistor. 2nd design identified by speedometer having two tell tale filters at bottom portion of dial.

- P76-3108-A each**74.95

- 1976 C10 Cab (exc H.D. chassis, tach) 1st design

- P76-3108-B each**39.95

- 1976 2wd, Ser. 20/30, w/ out tach, 2nd Design
- 1976 Suburban, Blazer (exc tach) 2nd Design
- 1976 2wd, Ser. 10, H.D. Chassis w/ out tach, 2nd Design

- 1977 2wd, Ser. 20/30 w/ out tach

- 1977 2wd, Ser. 10, H.D. Chassis w/ out tach

- 1977 Suburban, Blazer, w/ out tach

- 1978 2wd, Ser. 10/20, Pickup, Blazer (exc Calif)

- 1979 2wd, Ser. 10/30, Blazer w/ out tach & unleaded fuel

- P7679-3108-A each**99.95



- 1980 2wd, 10-30 w/ unleaded fuel only gauge, w/ tach

- P80-3108-A each**59.95

- 1980 2wd, Ser. 10-30 w/ unleaded fuel only gauge, w/ out tach

- P80-3108-B each**49.95

- 1980 2wd, Ser. 10-30 w/ out gauges

- P80-3108-C each**49.95

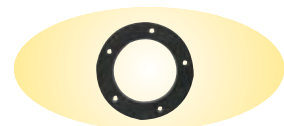

FUEL TANK GAUGE GASKET

- Rubber.
- 1938-60 All
- 1961-66 (exc 102" W.B.)
- 1963 4wd
- 1967-72 FFC - 72 Ser. 20-30 Fleetside w/ Aux Fuel Tank
- P3872-3112-A each**2.95



FUEL TANK GAUGE SCREW

- With washer. Requires 5 per gauge.
- 1960-64 All
P6064-3112-MB each1.95



FUEL SYSTEM, EXHAUST, CARB



SENDING UNIT GASKET

1967-72 Pickup
F6781-3112-G each 1.95
 1973 Ser 10/30
 1974-84 All, Blazer, Jimmy
F7073-3112-G each 8.95



FUEL FEED PIPE CLIP

Double pipe clip for 1/4" - 3/8" pipe.
 1938-72 All
P3872-3162-A each 1.95



FUEL FILLER HOSE

6" long
 1960-66 Pickup
P6066-3163-A each 9.95



FUEL SELECTOR SWITCH BEZEL

1976-78 Ser. 10-30 Cab 350
 1979-80 Ser. 10-30 Cab w/ Aux Fuel Tank
P7680-3164-A each 5.95



MANIFOLD CLAMP

AT exhaust ports. Requires 2 per vehicle.
 1963-65 D-Duti 4 Cyl
 1963-72 All 6 Cyl
P6372-3273-A each 7.95



INLET/EXHAUST CLAMP

Requires 4 per vehicle.
 1963-65 D-Duti 4 Cyl
 1963-72 All 6 Cyl
P6372-3273-B each 5.95

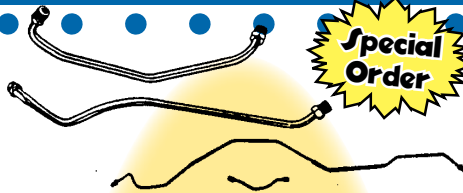

FUEL LINE TANK TO PUMP

Pre-bent to OEM specifications, correct color code fittings, fittings to match OEM machine double flare, spiral wound armor guard used as required per OEM specifications.

- All of the following are special order
- Please allow 2-3 weeks for delivery
- Please specify 3/8" or 5/16" & 2wd or 4wd

1947-50 Pickup (Plain steel)
P4750-3330-S each 71.95
 1947-50 Pickup (Stainless steel)
P4750-3330-SS each 59.95
 Flexible fuel line from tank to hard line.
 1949-53 Chevy/GMC Pickup
P4953-3330-A each 16.95
 1951-53 Pickup (Plain steel)
P5153-3330-S each 199.95
 1951-53 Pickup (Stainless steel)
P5153-3330-SS each 99.95
 1954-55 Pickup
P54-3330-A each 26.95
 1954-55 Pickup (Plain steel)
P5455-3330-S each 71.95
 1954-55 Pickup (Stainless steel)
P5455-3330-SS each 99.95
 1955-59 Chevy (Plain steel)
P5559-3330-S each 87.95
 1955-59 Chevy (Stainless steel)
P5559-3330-SS each 99.95
 1960-63 Chevy/GMC (Plain steel)
P6063-3330-SSPO each 71.95
 1960-63 Chevy/GMC (Stainless steel)
P6063-3330-SSSPO each 99.95
 1964-66 Chevy/GMC (Plain steel)
P6466-3330-SSPO each 71.95
 1964-66 Chevy/GMC (Stainless steel)
P6466-3330-SSSPO each 99.95
 1967-70 Chevy/GMC (Plain steel)
P6770-3330-SSPO each 71.95
 1967-70 Chevy/GMC (Stainless steel)
P6770-3330-SSSPO each 99.95
 1969-70 Blazer, Jimmy (Plain steel)
P6970-3330-SSPO each 79.95
 1969-70 Blazer, Jimmy (Stainless steel)
P6970-3330-SSSPO each 119.95
 1971-72 Chevy/GMC (Plain steel)
P7172-3330-ASSPO each 79.95
 1971-72 Blazer, Jimmy (Stainless steel)
P7172-3330-ASSSPO each 119.95
 1971-72 Chevy/GMC (Plain Steel)
P7172-3330-SSPO each 79.95
 1971-72 Chevy/GMC (Stainless steel)
P7172-3330-SSSPO each 99.95
 1973-80 Chevy/GMC (Plain steel)
P7380-3330-ASSPO each 79.95
 1973-80 Chevy/GMC (Stainless steel)
P7380-3330-ASSSPO each 119.95
 1973-80 Chevy/GMC (Plain steel)
P7380-3330-SSPO each 71.95
 1973-80 Chevy/GMC (Stainless steel)
P7380-3330-SSSPO each 99.95



AIR CLEANER ASSEMBLY

Complete with base, element, and lid. Painted black.
 Has 4-3/8" dia. opening for carb kit.
 1959-65 all with small block 4 brl.
 1965-66 1/2 ton Pickup with 327 cu.in. 4brl.
 1965-67 3/4-1 ton Pickups with 327 cu.in. 4brl.
A6465-3402-A kit 169.95



AUTOMATIC CHOKE ROD CLIP

1973-78 All, Blazer, Jimmy
F7176-3425-A each 1.95



ACCELERATOR PEDAL ROD RETAINER

1973-74 All
P7374-3425-A each 4.95



CARBURETOR TO ACCELERATOR LEVER ROD CLIP

1973-84 All
F7479-3425-A each 2.50



THROTTLE CABLE W/KNOB

1936-39 Pickup
 Black
P3639-3430-A each 32.95
 1940-46 Pickup
 Rose-tan knob
P4046-3430-A each 32.95
 1947-53 Pickup
 Maroon knob w/stainless accent
P4753-3430-A each 19.95
 1954-55 Pickup
 Black
P5455-3430-A each 24.95
 1955-59 Pickup
 Black
P5559-3430-TB each 19.95
 1955-59 Pickup
 Chrome
P5559-3430-TC each 19.95
 1960-63 Pickup
 Black and stainless
P6063-3430-TC each 19.95



FUEL SYSTEM, EXHAUST, CARB



1936-39 1947-53 1954-55 1955-59 1955-59
black chrome

THROTTLE KNOB

- 1936-39 Pickup
Black
P3639-3430-K each 9.95
- 1940-46 Pickup
Rose/tan
P4046-3430-K each 9.95
- 1947-53 Pickup
Maroon
P4753-3430-K each 9.95
- 1954-55 Pickup
Black
P5455-3430-K each 9.95
- 1955-59 Pickup
Black
P5559-3430-KB each 9.95
- 1955-59 Pickup
Chrome
P5559-3430-KC each 9.95



ACCELERATOR CABLE

- 1955 (8 Cyl)
1963-66 (exc 283 D-Duti)
1969-70 All & Blazer
14 1/2 dev. length
P5570-3430-A each 11.95
- 1971-72 Chevy/GMC Pickups
For 2 wheel drive Pickups with 350 or 400 cu. in. motors.
P7172-3430-A each 39.95
- 1971-72 4X4 Pickup and Blazers
For 4x4 Pickups and Blazers with 350 cu. in. motors.
P7172-3430-B each 29.95
- 1973 Ser. 10-30, Blazer, Jimmy 350
P73-3430-A each 29.95
- 1974 (2wd, 4wd, Ser. 10-30, Blazer, Jimmy 250, 454)
P74-3430-A each 24.95
- 1975 Blazer, Jimmy 250
1975-76 (2wd, Ser. 10/20 (exc H.D. Chassis)
1975-77 (2wd, Ser. 10-30 (454)
1977-78 (2wd, 4wd, Ser. 10/20, Blazer, Jimmy 250)
P7578-3430-A each 21.95
- 1975-77 (2wd, 4wd, Ser. 10-30, Blazer, Jimmy 305, 350, 400)
1978 (2wd, 4wd, Ser. 10/20 (305)
1979 (2wd, 4wd, Ser. 10 (305)
1980-81 2wd, Ser. 10 Blazer, Jimmy 305, 2 bbl
P7581-3430-B each 21.95
- 1978 (2wd, 4wd, Ser. 10-30 (350, 400, 454)
1979-82 All (4bbl)
P7882-3430-A each 21.95
- 1979-84 (2wd, 4wd, Ser. 10/20 (250)
P7984-3430-A each 29.95
- 1977-78 (2wd, 4wd, Ser. 30 (292)
1980-84 (2wd, 4wd, Ser. 20/30 (292)
P8084-3430-A each 19.95



THROTTLE LINKAGE

1955-59 Chevy GMC Truck
P5559-3430-TL kit 49.95

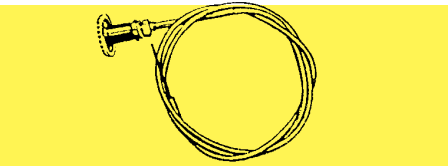

CHOKE CABLE W/KNOB

- 1936-39 Pickup (Black)
P3639-3431-CC each 36.95
- 1940-46 Pickup (Rose-tan)
P4046-3431-CC each 36.95
- 1947-53 Pickup (Maroon)
P4753-3431-CC each 19.95
- 1954-55 Pickup (Black)
P5455-3431-CC each 19.95
- 1955-59 Pickup (Black)
P5559-3431-CB each 19.95
- 1955-59 Pickup (Chrome)
P5559-3431-CC each 19.95
- 1960-63 Pickup (Black and stainless)
P6063-3431-CC each 19.95



CHOKE KNOB

- 1936-39 Pickup (Black)
P3639-3432-A each 9.95
- 1940-46 Pickup (Rose/tan)
P4046-3432-A each 9.95
- 1940-46 Pickup (Rose tan w/letter 'c')
P4046-3480-KN each 9.95
- 1947-53 Pickup (Maroon)
P4753-3432-A each 9.95
- 1954-55 Pickup (Black)
P5455-3432-A each 9.95
- 1955-59 Pickup (Black)
P5559-3432-B each 9.95
- 1955-59 Pickup (Chrome)
P5559-3432-C each 9.95
- 1964-66 Pickup (Black and stainless)
P6466-3480-A each 9.95

**We accept Visa, Master Card,
and Discover**



ACCELERATOR PEDAL

- 1938-40 Ser. 10/20, Chevy/GMC
P3840-3451-A each 21.95
- 1942-46 Pickup
P4246-3451-A each 21.95
- 1947-52 Pickup
P4752-3451-A each 14.95
- 1953-57 Pickup
P5354-3451-A each 14.95
- 1958-59 Chevy/GMC Pickup
P5859-3451-A each 14.95
- 1960-66 Pickup
P6063-3451-A each 14.95
- 1967-70 All Standard
P6770-3451-A each 12.95
- Deluxe style - made for trim
1967-70 Pickup
P6770-3451-DLX each 14.95
- 1971-72 All
P7172-3451-A each 4.95
- 1973 Ser. 10-30, Blazer, Jimmy
P73-3451-A each 9.95

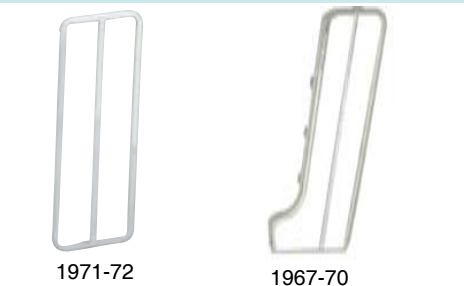

TRIM RING FOR ACCELERATOR PEDAL

- Stainless steel.
1967-70 Chevrolet Pickup
P6770-3451-TR each 19.95
- 1971-72 Chevrolet Pickup
P7172-3451-TR each 5.95



FUEL SYSTEM, EXHAUST, CARB

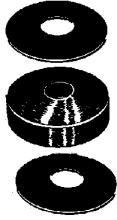

ACCELERATOR SHAFT FLOOR SEAL

3 pc. set. Includes 1 felt & 2 fiber washers as original.

1947-59 Pickup

P4759-3452-A each 2.95



ACCELERATOR PIN & ROD

1953-57 Pickup

P5357-3452-A each 4.95



ACCELERATOR PEDAL STUD ASSEMBLY

1964-66 Pickup

P6466-3452-A each 15.95



ACCELERATOR PEDAL PIN

1973-75 All

F6781-3452-A each 5.95



ACCELERATOR PULL BACK SPRING

1950-59 (6 Cyl)

5 3/4" free length - ends hooked.

P5059-3459-A each 3.95

1975 All, Blazer, Jimmy

F7281-3459-A each 4.95

1974-78 All (6 Cyl)

1979-84 All (292)

P7484-3459-A each 10.95

1974-80 All

Outer

F7681-3459-A each 2.29

1974-80 All (8 Cyl)

Inner

F7681-3459-B each 2.29

STARTER BOOT

For floor push starter.
1938-57 Pickup

P4754-3469-A each 5.95

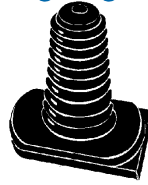

HAND THROTTLE CONTROL ROD & TUBE ASSEMBLY

1973-75 2wd, 4wd, Ser. 10-30, Blazer, Jimmy w/ manual throttle

1974-76 (2wd, Ser. 10-30, w/ Calif Emission

(454) Fuel Tank Selector Cable Knob

1979-84 (350) - Hand Throttle Control Rod & Tube

P7384-3481-A each 8.95



EXHAUST MANIFOLD SEAL RING

1973-78 All, Blazer, Jimmy (exc 454)

1979-84 Pickup

F7678-3611-A each 6.95



2 1/4 INCH T-BOLT CLAMP

Designed to mount the rolled edge megaphone tips onto your tailpipe.

P-3700-CLA each 5.95

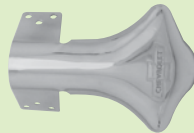

CHEVROLET BOW-TIE EXHAUST DEFLECTOR

Stamped, polished Stainless steel. Clamps to tail pipe.

Pickup All

P-3700-BT each 14.95



TAIL PIPE HANGER BRACKET

With insulator. Use your old part as a guide for hole location and cut off excess insulator length.
1938-72 All

P3872-3706-A each 14.95

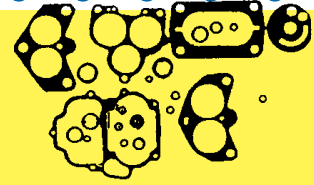

CARBURETOR REBUILDING KIT

1932-34 (6 Cyl)

1937-40 (6 Cyl)

Fits carter w1 1bbl.

P3240-3725-RKA kit. 39.95

1932-62 Pickup 216, 235 & 261

Rochester 1bbl carbs

P3262-3725-RKA kit. 29.95

1946-52 Pickup 216

1950-52 Pickup 235

Fits Stromberg 1bbl. carbs

P4652-3725-RKA kit. 59.95

1955-59 GMC Pickup 288, 302, 316, 336 & 347

Fits Stromberg 2 bbl carbs with the following applications...

P5559-3725-RKA kit. 52.95

1955-67 Pickup 265 & 283 Engines

Fits Carter 2bbl carbs

P5567-3725-RKA kit. 54.95

1955-68 Pickup 265 & 283

Rochester 2 bbl

P5568-3725-RKA kit. 29.95

1957-67 Pickup 283, 327, 348 & 409 Engines

Rochester 4bbl

P5767-3725-RKA kit. 32.95

1963-67 Pickup 230, 292 Engines

1966 Pickup 194 Engine

1966-67 Pickup 250 Engines

1966-67 GMC Pickup 260, 292 Engines

Rochester 1bbl

P6367-3725-RKA kit. 23.95



CARBURETOR INSULATOR PLATE

1937-62 All with 1-1/2" bore carbs

Fits between intake and carb. Used as a heat transfer for 1-1/2 inch bore.

P3762-3726-A each 12.95

1951-62 All with one barrel 1-3/4" bore carbs

Fits 1-3/4 inch bore one barrel carbs.

P5162-3726-A each 12.95



CARB FUEL INLET FILTER

1973 Ser. 20/30 (307)

1973-74 All, Blazer, Jimmy w/ 4 BC

1973-76 All w/ Rochester - 1BC

1974-76 All, Blazer, Jimmy w/ 2 BC

1975-76 2wd, Ser. 10 Cab w/ H.D.C 454

1975-76 2wd, Ser. 10, Suburban 350, 454

1975-76 4wd, Ser. 10/20, Blazer, Jimmy 350, 400

1977 2wd, Ser. 20/30 (454) exc NB2

1977 4wd, Ser. 10/30, Blazer, Jimmy 350, 400

1977 2wd, Ser. 10 Suburban, Blazer, Jimmy

w/4BC (350)

F6775-3740-F each. 2.95

**Can't find it?
Call us - we'll get it
for you!**

FUEL SYSTEM, EXHAUST, CARB



CHOKE CONTROL THERMOSTAT

Automatic
 1973-74 All 454
 1973-74 All
 1975-76 All 454 (exc NB2)
F7374-3750-A each21.95



FUEL FILTER UNIT

AC-GF-62-C
 1968-69 Ser. 10-30 (exc. 327, 350, 396)
P6869-3890-FF each44.95



FUEL PUMP MOUNTING PLATE

4 attach. holes - 2-19/32" x 5-51/64
 1955-57 Ser. 3 (8 Cyl)
 1971-72 All, Blazer (307, 350)
 1958-66 (8 Cyl)
 1967-68 (283, 307, 327)
P5572-3901-A each9.95



FUEL PUMP

1937-51 Pickup L6 (Single Action)
PU3751-3900-A each39.95
 1942-51 All (Dual Action)
PU4252-3900-A each89.95
 Late 1952-55 All (Dual Action)
PU5255-3900-A each99.95
 1952-57 (6 Cyl) (Single Action)
PU5257-3900-A each39.95
 1955-57 (8 Cyl) (Single Action)
PU5557-3900-A each54.95
 1958 (283 exc. 5000 Series) (Single Action)
PU58-3900-A each44.95
 1958 (6 Cyl, 261, 235 w/ Electric Wipers)
 1959-62 (235, 261 w/ Electric Wipers)
 Single action
PU5862-3900-A each34.95
 1958 (235 w/ Vacuum Wipers)
 1959-62 (235, 261 w/ Vacuum Wipers)
 Dual action
PU5862-3900-B each86.95

1958 (283, 5000 Series)
 1959-61 (8 Cyl, exc 283)
 1962-64 (327, 348, 409)
 1964-66 (327)
 Single action
PU5866-3900-A each49.95
 1959-61 (283 1 Ton)
 1960-61 (283, exc 4wd)
 1962-66 (283, All)
 Single action
P5966-3900-B each29.95
 1963 (6 Cyl, 292 w/ 35 1/2" Line From Fuel
 Pump to Carburetor)
 1963-64 (194, 230)
 1963-65 (4 Cyl 153 - 6 Cyl)
 1965 (194, 230, 250)
 Single action
PU6365-3900-A each34.95
 1963 (292 w/ 48 1/4" Line from Pump to Carbu-
 retor)
 1964-Early 1965 (292)
 Single action
PU6365-3900-B each39.95

Save on shipping - We'll deliver to any swap meet we attend. Just ask for details!

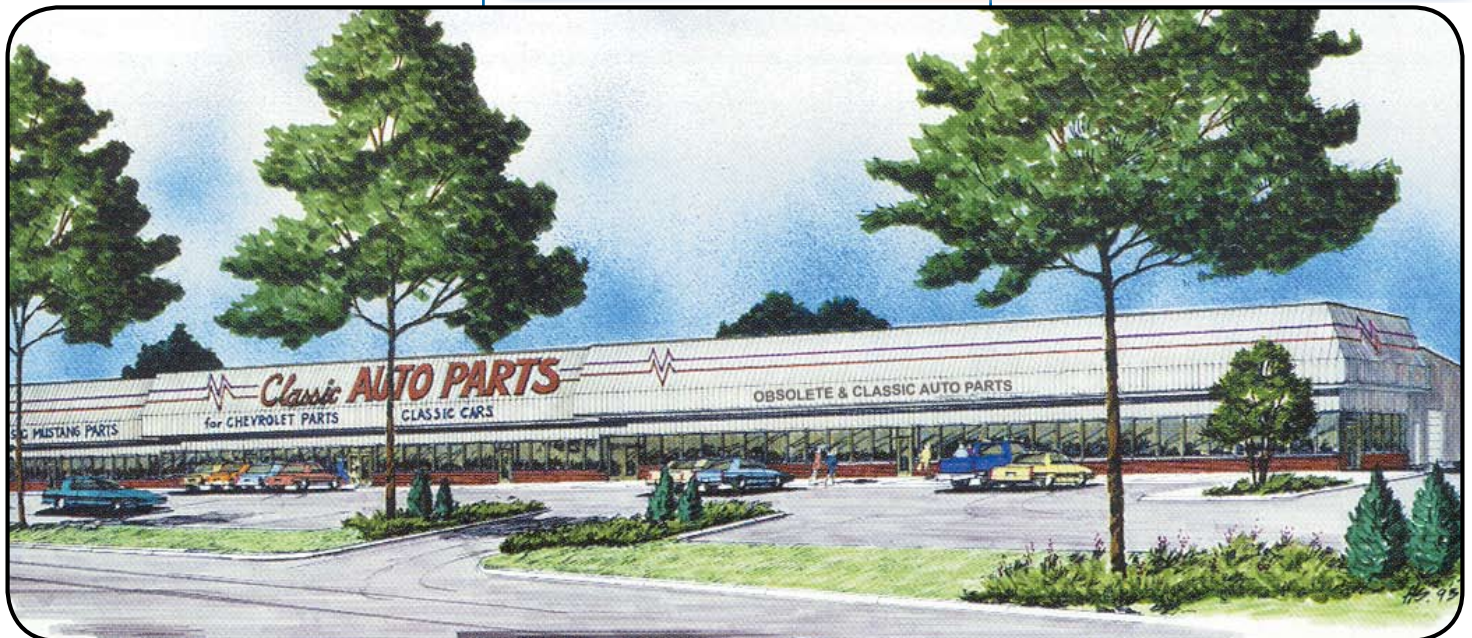

Be sure to stop by our store in Oklahoma City!



TRANSMISSION & BRAKES

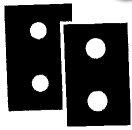

TRANSMISSION MOUNT PADS

3-speed
1948-55 Pickup
P4855-4003-AS pair11.95

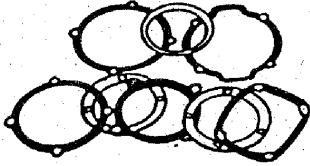

TRANSMISSION GASKET SET

Includes 1 trans. extension gasket, 1 trans. cover gasket, 1 clutch gear bearing retainer gasket & 1 'O' ring seal.
1966-72 Pickup & Blazer w/ Saginaw Trans.
P6672-4005-GS set14.95



GEAR SHIFT BOX SHAFT BOOT

1947-59 Pickup (All)
P4754-4006-BOOT each4.95

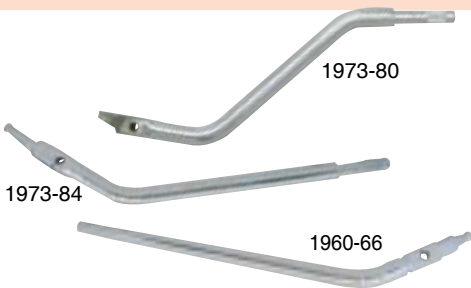

CHROME SHIFT LEVER

1960-66 Pickup (3-speed & auto shift chrome lever)
P6066-4006-A each27.95
1967-68 Ser 10-20 (exc. D-D) (8 1/8" o.l.)
P6768-4006-A each29.95
1969-70 Ser 10-30 (exc. D-D) (No tilt shift lever)
P6970-4006-A each27.95
1973-80 2wd, 4wd, 10-30, Blazer, Jimmy w/ T.W. (T.H.)
For column shift
F6976-4006-A each69.95
1970-72 Pickup
Chrome gear shift lever used w/ tilt wheel less knob
P7072-4006-A each49.95
1971-72 Pickup & Blazer
No tilt 3 speed or automatic, chrome
P7172-4006-A each27.95
1973-84 Ser. 1-2, Blazer, Jimmy (3spd)
P7384-4006-A each144.95
1973-78 2wd, 4wd, Ser. 10-30, Blazer, Jimmy
1979-84 All (M20)
P7384-4006-C each144.95



1929-47
1973-77
1960-66
1936-66
1967-72
1948-53
GEAR SHIFT KNOB
1929-47 Pickup (Black, for floor shifters)
P2947-4570-A each10.95
1936-39 Pickup (4 spd, black)
P3639-4009-4SP each9.95
1936-66 Pickup (4 speed, black)
P4754-4009-4SP each9.95
1947-53 Pickup (Maroon, 3 speed)
P4853-4009-3SP each6.95
1948-53 Pickup (Brown, goes with brown interior)
P4853-4009-A each7.95
1954-55 Pickup (3 speed, black)
P54-4009-3SP each6.95
1955-59 Pickup (3-speed & auto shift black knob)
P5559-4009-A each4.95
1960-66 Chevy/GMC Pickup
(Black, fits 3 speed standard or auto. columns)
P6066-4009-A each8.95
1967-72 Chevy (3 Speed & Automatic. Correct style for 1971-72. Will work for 1967-70, only difference is textured end.)
P6772-4009-A each7.95
1973-77 2wd, 4wd, 10-30, Blazer, Jimmy (Turbo Hydramatic)
1973-77 2wd, 4wd, 10-30, Blazer, Jimmy (3 spd)
1979-84 All w/ AT
1978 2wd, 4wd, 10-30, w/ MT (3 Spd) (Black)
F7177-4006-K each8.95
1973-87 Pickup (3 speed and auto shift knob)
P7387-4009-A each6.95



4-SPEED FLOOR SEAL

4-speed floor seal sponge. Fits between trans & floor plate. Originally used instead of or in addition to a boot.
1947-66 Pickup
P4754-4008-A each7.95



SHIFT ROD GROMMET

With metal lining.
1947-66 Pickup
P4766-4008-A each2.95



MOUNT TRANSMISSION SHIFTER BOOT

Rubber
1947-66 Pickup (All)
P4766-4008-FB each8.95
1971-72 All
P7172-4010-A each29.95
1973-78 2wd, 4wd, Ser. 10-30, w/ MT
1979-83 All ,w/ MT (M20)
P7383-4015-A each26.95



EMERGENCY BRAKE BOOT

1947-54 Pickup
P4754-4015-A each9.95



CONTROL LEVER BOOT RETAINER

Floor mounted
1968-72 Ser 10-30 Blazer w/ 4 speed 6 cyl
1973-78 2wd, 4wd, Ser. 10-30, Blazer, Jimmy
1979-83 All w/ MT (M20)
P6872-4015-LBR each8.95



STEERING COLUMN CLAMP BUSHING

1936-46 Pickup
P3646-4016-A each3.95
1947-53 Pickup
P4753-4016-A each1.95
1947-59 Pickup
P4754-4016-RB pair2.95
1954-55 Pickup
P5455-4016-A each1.95
1955-59 Pickup
P5559-4016-R each2.95

www.classicchevroletparts.com

TRANSMISSION & BRAKES



COLUMN TO DASH PAD

1955-59 Pickup
P5559-4016-B pair2.95



SHIFT BOX GREASE PLUG

Transmission grease plug that is removed to check grease in transmission.
 1947-59 Pickup
P4759-4016-GP each1.95



INDICATOR DIAL POINTER

For automatic with tilt
 1970-72 All, Blazer
P7072-4020-A each5.95



SHIFT INDICATOR HOUSING

1971-72 w/out tilt
P6266-4020-H each11.95
 1971-72 Chevy/GMC, Blazer, Suburban
 Used without tilt wheel
P7172-4020-H each7.95
 1971-72 Pickup
 Fits all with tilt wheel
F68-4022-A each9.95



SHIFT INDICATOR LENS

1962-66 Chevy/GMC Pickup
P6266-4020-L each7.95
 1971-72 Chevy/GMC, Blazer, Suburban
 Used with three speed automatic without tilt wheel
P7172-4020-L each9.95

Visit
www.classicchevroletparts.com
 for all your Pickup needs!



1971-72



1973-78

SHIFT INDICATOR POINTER

1971-72
 For automatic without tilt.
P7172-4020-P each9.95
 1973-78 2wd, 4wd, Ser. 10-30 Blazer, Jimmy
 (Turbo Hydramatic)
P7378-4020-B each6.95
 1979-84 2wd, 4wd, Ser. 10-30
 Yellow pointer
P7984-4020-A each12.95



SHIFT INDICATOR SCREW SET

1967-72 Pickup
P6772-4021-SC set.95



SHIFTER LEVER BUSHING

Anti-rattle rubber bushing (on column)
 1947-59 Pickup
P4759-4027-C each3.95



COLUMN SUPPORT RETAINER RING

1973-84 Ser. 10/30 with Tilt Wheel
F6973-4027-A each7.95



COLUMN SHIFTER BOOT

Mounts on column shift box
 1947-59 Pickup
P4759-4030-A each1.95



SHIFT LEVER BUSHING KIT

3-speed
 1948-53 Pickup
P4853-4037-AS set of 23.95
 1954-55 Pickup
P5455-4037-AS set of 67.95
 1955-59 Pickup
P5559-4037-AS set of 45.95

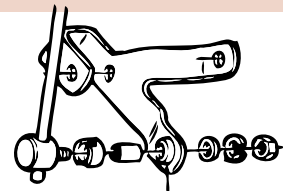

CONTROL SHIFTER GROMMET

3/4" o.d. x 1/2" i.d. x 5/16" thick- rubber
 1973-76 All
 1976-78 Pickup w/ AT (Turbo-Hydramatic)
F6775-4037-A each1.95



TRANSMISSION CONTROL ROD BUSHING AND SLEEVE KIT

1974-79 All
 1979-80 All (3spd MT)
 1979-80 All w/ AT
F6781-4037-A each2.95



1973-83



1973-78

TRANSMISSION CONTROL ROD SWIVEL

1973-83 All, Blazer, Jimmy (3 spd)(turbo-hydramatic)
F6781-4037-S each18.95
 1973-78 All 3 spd mt MC1, M15
 1979-84 All w/AT
F7781-4037-S each8.95



TRANSMISSION CONTROL ROD GROMMET

1973-76 All
 5/16"
P7376-4037-A each1.95
 1973-78 Ser. 10-30, Blazer, Jimmy (3spd,
 Turbo-Hydramatic)
 1979-82 All 3spd M/T
 1979-84 All with A/T
P7382-4037-B each1.95



TRANSMISSION & BRAKES



SHAFT SPRING WASHER

Transmission control equalizer shaft spring washer
1973-76 2wd, 4wd, Ser. 10-30, Blazer, Jimmy (3 Speed, Turbo Hydramatic)
P7376-4037-B each 1.95



GEAR SHIFT CONTROL ROD WASHER

1973-77 All
1979-81 2wd, 4wd, Ser. 10-30 (Washer for Bumper Bar)
13/32" i.d. x 1" o.d. x 9/16" thick
P7377-4037-A each 95
1973-77 All 4 Speed
1973-78 All 3 Speed
13/32" i.d. x 3/4" o.d. x 1/32" thick
P7378-4037-A each 2.95



LOWER KICK DOWN ROD SWIVEL

8 cyl. and powerglide trans
1964-72 All
A6472-4050-KDR each 39.95



BACK UP LAMP SWITCH

1960-72 Ser. 10-20 (Powerglide)
P6072-4054-A each 44.95
1967-70 Ser 10 Thru 30 (exc. D-D & 4wd)
1971 Series 10 Thru 30 & Blazer
P6771-4054-A each 69.95



BEZEL TO GLASS GASKETS

1940-46 Pickup
P4046-4339-GG set 5.95
1947-53 Pickup
P4753-4339-GG pair 5.95
1954-55 Pickup
P5455-4339-GG set 4.95
1955-59 Pickup
P5559-4339-GG set 2.95



TRANSMISSION MOUNT/REAR MOTOR MOUNT

1960-96
1934-54 (2nd) 1934-54 (1st)
P3455-4081-A each 14.95
1934-54 (261 1st design)
1941-53 (216 1st design)
1947 (194 Early 1st design)
1948-53 (230 1st design)
1948-55 (235 1st design)
1934-54 (261 2nd design)
1934-54 Late 47 2nd design
1941-53 (216 2nd design)
1948-55 (235 2nd design)
1948-55 (230 2nd design)
P4155-4081-A each 14.95
1956-65 Chevy Pickup (235 w/ Powerglide)
1960-62 Chevy Pickup (261 w/ Powerglide)
1960-62 Chevy Pickup (283 w/ Powerglide Trans)]
1963-67 (283 w/ Powerglide)
1963-72 Chevy Pickup (293 Automatic Tran)
1966-72 (250 exc TH400)
1968-72 (307 Engine)
1973 (307 exc TH400)
1973-81 (250, 350 exc TH400)
1973-81 (292 exc TH400)
P5672-4081-A each 8.95
1960-96 Pickup
Urethane transmission mount. Fits various models with 1 or 2 bolt style transmission to crossmember mounting.
P5672-4081-UR each 49.95
1963-72 (292 w/AT-TH400)
1965-68 (327 -TH400)
1968-72 (307 TH400)
1973-81 (250 exc TH400)
1973-81 (292, 350 exc TH400)
F6775-4081-A each 8.95

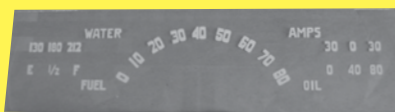

SPEEDOMETER GLASS LENS

Clear acrylic with white lettering. Reads 0 - 80 mph.
1940-46 GMC Pickup
P4046-4339-GMC each 21.95



INSTRUMENT CLUSTER BEZEL

1947-53 Pickup (Chevy/GMC)
Chrome, for speedometer & gauges
P4753-4339-CH each 14.95
1954-55 Pickup
Stainless steel
P5455-4339-SS each 19.95



DASH GAUGE REFACING KIT

1936-39 Pickup (Chevy)
Cream colored
P3639-4339-AS each 19.95
1936-39 Pickup (GMC)
Cream colored
P3639-4339-BS each 19.95
1940-46 Pickup (GMC)
Tan
P4046-4339-BS kit 19.95
1947-51 Pickup (Chevy)
Brown
P4751-4339-AS each 19.95
1947-51 Pickup (GMC)
Cream
P4751-4339-BS each 19.95
1952-53 Pickup (Chevy/GMC)
Brown
P5253-4339-AS each 19.95
1954-55 Pickup (Chevy)
Black & light green
P5455-4339-AS each 14.95
1954-59 GMC Pickup
Black and white, for 80 and 100 mph gauge
P5459-4339-AS kit 19.95
1960-66 Pickup (GMC)
White on black
P6066-4339-AS kit 19.95

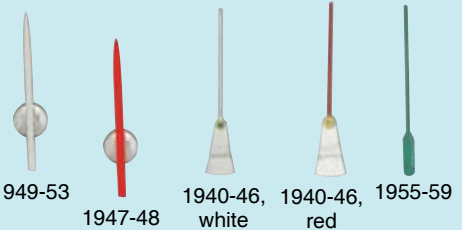

SPEEDOMETER NEEDLE

1940-46 Pickup
Red
P4046-4339-RSN each 14.95
1940-46 Pickup
White
P4046-4339-WSN each 14.95
1947-48 Pickup
Red
P4751-4339-RSN each 9.95
1949-53 Pickup
White
P4953-4339-WSN each 6.95
1955-59 Pickup
Green
P5559-4339-SN each 7.95

We accept Visa, Master Card, and Discover.

TRANSMISSION & BRAKES

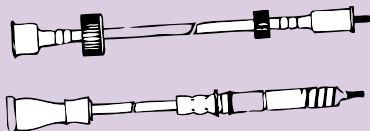

SPEEDOMETER CABLE

- 1937-46 Pickup
- 1947-69 Series 10, 77" Long
- 1955-70 Series 10, 64" Long
- P3770-4342-A each34.95**
- 1938-69 Pickup (Series 10, 55" Long) w/casing
- P3869-4342-A each19.95**
- 1947-54 Pickup (3 or 4 Speed)
- Cable and housing, 68" long
- P4754-4342-A each19.95**
- 1955-70 Pickup (Series 10, 56 to 60" Long) 3 or 4 speed
- P5570-4342-A each19.95**
- 1957-69 Pickup (Series 10, 92" Long)
- P5769-4342-A each46.95**
- 1978 2wd, Ser. 10-30 w/ H.D.C. w/ cruise control (exc Calif.) 3 & 4
- 1978 4wd, Ser. 10-30, w/ H.D.C. Cruise Control (exc Calif) 3 & 4 Speed w/ Cruise Control
- 1980 2wd, Ser. 20-30, (350, 454) M40, w/ Cruise
- 55" casing
- F6769-4342-AS each46.95**
- 1975-76 Blazer, Jimmy (w/ Speed & cruise control)
- 1975-78 2wd, Ser. 10, Cab w/ Speed, Cruise Control (exc H.D. Chassis) Turbo Hydramatic
- Speed and cruise cable w/casing (regulator to speedometer)(40" o.l.)
- F6769-4342-B each66.95**
- 1978 4wd, Ser. 20/30, w/ AT, Cruise Control, Dual Exhaust (exc Calif)
- 1979 4wd, Ser. 20/30, M40, w/ Cruise Control (exc Dual Exh) 84" casing
- F6770-4342-AS each49.95**



PLASTIC SPEEDO CABLE STRAP

- 1938-72 All
- F7374-4342-S each1.95**

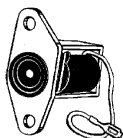

TRANSMISSION KICK DOWN SOLENOID

- 1964-80 Chevy/GMC
- P6480-4480-A each14.95**



1947-53



1954-55

EMERGENCY BRAKE RELEASE KNOB

- Chrome.
- 1947-53 Pickup
- P4753-4592-A each11.95**
- 1954-55 Pickup
- P54-4592-A each9.95**



PARKING BRAKE HANDLE

- Black
- 1971-74 Ser 10-30 & Blazer (exc. D-D)
- P7172-4592-HA each3.95**
- 1973-84 2wd, 4wd, Ser. 10-30, Blazer, Jimmy
- P7384-4592-HA each16.95**



EMERGENCY BRAKE RELEASE ROD GROMMET

- 1947-55 Pickup
- P4754-4594-G each1.95**
- 1969-72 Ser 10-30 & Blazer (exc. D-D)
- P6972-4594-G each4.95**



thru firewall

on dash

PARK BRAKE PEDAL GROMMET

- 1973-84 2wd, 4wd, C,K-1,2,3, Blazer, Jimmy
- Fits thru firewall.
- P7384-4594-A each4.95**
- 1974-84 2wd, 4wd, C,K-1,2,3, Blazer, Jimmy
- Fits on dash.
- P7484-4594-A each4.95**

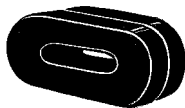

PARK BRAKE FOAM COLLAR SEAL

- For trucks having vertical hand pull lever.
- 1947-59 Pickup
- P3459-4612-A each4.95**



PARKING BRAKE FLOOR BOOT

- 1948-55 Pickup & Panel Delivery
- P4855-4612-A each7.95**



PARKING BRAKE LEVER FLOOR BOOT METAL COVER

- 1948-55 Pickup & Panel
- P4855-4612-MC each.....9.95**



CLUTCH & BRAKE PEDAL SHAFT BUSHINGS

- 1932-46 Pickup
- P3246-4626-AS pair.....16.95**
- 1947-54 Pickup
- P4754-4626-A pair.....14.95**
- 1955-59 Pickup
- P5559-4626-AS set.....26.95**
- 1975-84 2wd, 4wd, 10-30, Brake
- 1975-84 2wd, 4wd, 10-30 (exc AT) Clutch
- P7584-4626-A each1.95**



PARKING BRAKE PEDAL TRIM

- Stainless steel
- 1971-72 Chevy Pickup
- P7172-4630-PBT each4.95**



CLUTCH PEDAL TRIM

- Stainless steel
- 1971-72 Chevy Pickup
- P7172-4630-PT each7.95**





TRANSMISSION & BRAKES



1960-70



1971-72



1974-83



1973-74

PARK BRAKE PAD

- 1960-70 Chevy
Parking brake pad
P6070-4630-PBP each 3.95
- 1971-72 Chevy Pickup
Deluxe parking brake pedal, accommodates stainless steel trim ring.
P7172-4630-PBP each 3.95
- 1973-74 2wd, 4wd, Ser. 10-30, Blazer, Jimmy
Park brake pedal cover
P7374-4630-A each 7.95
- 1974-83 Ser. 10/30, Blazer, Jimmy
Parking brake pad. Note: (trim plate available F6768-4630-TP)
F6768-4630-A each 3.95



1947-59



1960-70



1971-72



1973-74



1974-84



1973

BRAKE/CLUTCH PEDAL PAD

- 1947-59 Pickup
P4754-4630-A each 3.95
- 1960-70 Ser 10-30 (exc. D-D)
1971-72 Ser 10-30 & Blazer
Waffle style
P6070-4630-CA each 3.95
- 1971-72 Pickup
Accommodates stainless trim.
P7172-4630-CS each 3.95
- 1973-74 (2wd, 4wd, Ser. 10-30, Blazer, Jimmy) (AT w/ Vacuum Brakes)
P7378-4630-A each 10.95
- 1973 (2wd, 4wdm Ser. 10-30, Blazer, Jimmy (exc AT)
1973-74 (2wd, Ser. 10, (exc Brake booster)
1974 (2wd, 300)
1975-81 (2wd, 4wd, Ser.10-30, Blazer, Jimmy (exc AT)
1979-81 (2wd, Ser. 10 (2 dr) w/ AT, Manual brakes)
P7381-4630-B each 7.95
- 1974-84 (2wd, 4wd, Ser. 10-30, w/ 3 spd, 4 spd)
P7484-4630-A each 4.95



BRAKE SHOE RETAINING CONE SPRINGS

- 1936-48 Pickup
P3648-4639-AS each 5.95
- 1947-50 Pickup
P4750-4639-AS set of 4 14.95

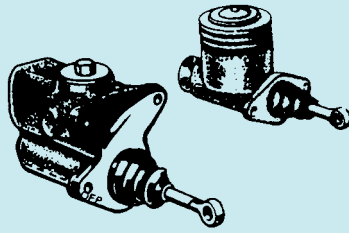

MASTER CYLINDER

- 1936-46 1/2 Chevy or GMC 3 Speed
For the 1/2 ton 3 speed. This is correct with the one inch bore and vertical mounting bolts. No core charge.
P3646-4650-A each 179.95
- 1947-50 (1/2 ton)
For drum brakes. 1" bore.
PU4750-4650-A each 139.95
- 1951 (1/2 Ton)
1953-55 (3/4 & 1 Ton Cab Forward double duty)
PU5155-4650-A each 164.95
- 1952-55 (1/2 Ton)
1953-55 (3/4 & 1 Ton Ton 1st series in '55)
PU5255-4650-A each 179.95
- 1955-59 - 1955 2nd Series - 1959 - Ser. 10-30 Ton
1 1/8" bore
PU5559-4650-A each 149.95
- 1960-62 (3/4 Ton w/ Power Glide, 3/4 Ton w/ 4wd power glide)
1960-63 (1/2 Ton)
1963-66 All (1 Ton)
1963-66 (1/2 & 3/4 ton flat faced cowl- no booster)
PU6066-4650-A each 114.95
- 1963-66 (1/2 Ton w/ 4wd, w/ out flat cowl)
1963-66 (3/4 Ton, 4wd, w/ out flat cowl)
PU6366-4650-A each 74.95
- 1967-70 (1/2 Ton, & 1 1/2 Ton w/ 4wd)
PU6770-4650-A each 99.95
- 1973-80 (1/2 Ton, 4wd)
1973-80 (1/2 Ton, All)
For disc brakes. With delco.
PU7378-4901-A each 69.95



MASTER CYLINDER FLOOR PLUG

- Painted black.
1939-46 Chevy/GMC All
P3946-16545-A each 9.95
- 1947-59 Pickup
P4750-16545-A each 6.95

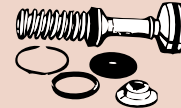

MASTER CYLINDER REPAIR KIT

- 1936-50 (1/2 Ton)
For 1/2 ton Pickups
PU3650-4650-RK kit 19.95
- 1938-52 (3/4 Ton)
PU3752-4650-RK kit 24.95
- 1951-59 All
1953-59 3/4 Ton
PU5159-4650-RK kit 24.95
- 1960-62 Glide Trans (AT), 2wd, Ser.10/20
1963-66 2wd, Ser. 10/20 w/ Cowl w/ out Buster
1964-66 All 2wd, Ser. 30
PU6066-4650-RK kit 24.95
- 1963-66 2wd, 4wd, Ser. 10 w/ Bendix Booster
1964-66 4wd, Ser. 20, w/ Bendix Booster
1965-66 2wd, Ser. 20 w/ Bendix Booster
PU6366-4650-RK kit 16.95
- 1963 4wd, Ser. 10 w/ out Buster
1963-66 4wd, Ser. 20, w/ out Buster
1964 4wd, Ser. 10 w/ Moraine booster
1964-66 2wd, Ser. 10/20, 4wd, Ser. 10 w/ out Buster or flat faced cowl
PU6366-4650-RKB kit 16.95
- 1967-70 2wd, 4wd, Ser. 10 w/ Booster
PU6770-4650-RK kit 29.95
- 1967-70 2wd, 4wd, Ser. 10 w/ out Booster
For drum brakes.
PU6770-4650-RKB kit 21.95
- 1967-70 2wd, 4wd, Ser. 20 w/ Moraine cylinder except booster
Disc brakes
PU6770-4650-RKC kit 21.95
- 1967-70 2wd, 4wd, Ser. 20 w/ Bendix cylinder
PU6770-4650-RKD kit 34.95

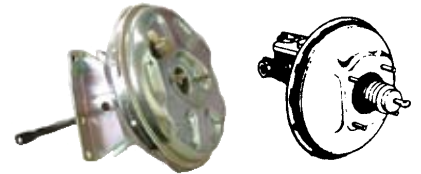

POWER BRAKE BOOSTER

- Original style, plated.
1962-66 Chevy/GMC Pickup
P6266-4901-A each 249.95
- 1967-70 Chevy/GMC Pickup
P6770-4901-A each 249.95
- Delco-moraine, rebuilt, show quality gold iridite plating
1971-72 Pickup
P7172-4901-A each 249.95

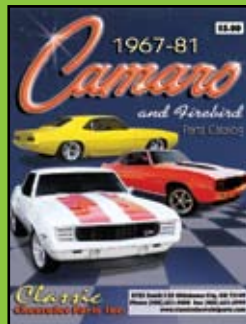

Don't miss our **NEW**
Camaro catalog!
Order yours today!

TRANSMISSION & BRAKES



REAR WHEEL CYLINDER KIT

- 1936-50 (Ser. 10)
- 1937 (Ser. 30)
- 1939-42 (Ser. 20)
- 1-3/16" cylinder bore
- PU3650-4665-RBK kit17.95**
- 1951-73 Ser. 10, All
- 1" cylinder bore
- PU5170-4665-RBK kit9.95**



FRONT WHEEL CYLINDER KIT

- 1936-50 (Ser. 10, All)
- 1938-52 (Ser. 20)
- PU3652-4665-RKA each19.95**



WHEEL CYLINDER REPAIR KIT

- 1951-70 All, 2wd, Ser. 10 - Front
- 1953-70 2wd, 4wd, Ser. 20 - Rear
- 1953-70 2wd, Ser. 20/30, 4wd, Ser. 10
- 1957-59 All, 4wd, Ser. 10 w/ 1 1/8" Front Cylinder
- 1957-59 4wd, Ser. 30
- 1960 All, 4wd, Ser. 10
- 1964-70 All, 4wd, Ser. 10
- PU5170-4665-RKA kit9.95**

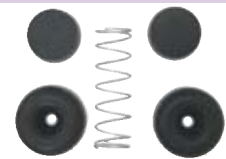

REAR DISC WHEEL CYLINDER REPAIR KIT

- 1" cylinder bore
- 1974-84 2wd, Ser. 10/20, 4wd, Ser. 10, All w/ 11 5/32" X 2 3/4"
- PU7478-4665-DRCK kit12.95**

Rear Wheel Cylinders



REAR WHEEL CYLINDER

- 1936-50 (Ser. 10)
- Fits either side - 1 3/16" bore
- PU3850-4665-RRL each64.95**
- 1938-40 Ser. 10
- 1946-52 Ser. 30 - Front * Ser. 20 - Rear
- Fits either side.
- PU3852-4665-RR each69.95**
- 1951-55 (Ser. 10)
- Fits either side.
- PU5155-4665-RRL each44.95**
- 1955-70 (2nd Series, Ser. 10)
- 1971-73 (Ser. 10 & Ser. 10 w/ 4wd - Disc Brakes)
- 1958-59 (Ser. 10 w/ Positraction)
- Left hand
- PU5570-4665-RL each19.95**
- 1955-70 (2nd Series, Ser. 10)
- 1971-73 (Ser. 10, Ser. 10 w/ 4wd - Disc Brakes)
- 1958-59 (Ser. 10 w/ Positraction)
- Right hand
- PU5570-4665-RR each19.95**
- 1958-59 (Ser. 10 w/ Positraction)
- Left hand
- PU5859-4665-RL each39.95**
- 1958-59 (Ser. 10 w/ Positraction)
- Right hand
- PU5859-4665-RR each39.95**
- 1965-70 All w/ Leaf Springs, Dana R.A. 2wd, Ser. 20
- 1964-69 4wd, All (exc Locking hub)
- 1970 All 4wd, Ser. 10
- Left hand
- PU6570-4665-RL each44.95**
- 1965-70 All w/ Leaf Springs, Dana R.A. 2wd, Ser. 20
- 1964-70 (4wd, Ser. 10)
- Right hand
- PU6570-4665-RR each44.95**
- 1974-84 (Ser. 10, w/ 4wd w/ 2" Disc Brakes)
- Fits either side.
- PU7478-4665-DLR each34.95**



FRONT WHEEL CYLINDER

- 1936-50 Ser. 10
- 1937-42 Ser. 20
- 1939-52 Ser. 20, All
- Fits either side - 1 1/4" bore.
- PU3752-4665-FRL each64.95**
- 1951-59 Ser. 10
- 1960-63 4wd, Ser. 20
- 1964-69 All, 4wd, Ser. 20 (exc. Front Locking Hub)
- 1964-69 4wd, Ser. 10
- Right hand
- PU5169-4665-FRL each39.95**
- 1951-59 (Ser. 10)
- 1960-63 (Ser. 20, 4wd)
- 1964-69 (4wd, Ser. 20)
- 1964-69 (4wd, Ser. 20 (exc Front Hub))
- Left hand
- PU5169-4665-FRLB each39.95**
- 1960-63 (Ser. 10)
- Left hand
- PU6063-4665-FL each44.95**
- 1960-63 (Ser. 10, 4wd)
- Left hand
- PU6063-4665-FL4 each64.95**
- 1960-63 (Ser. 10)
- Right hand
- PU6063-4665-FR each44.95**
- 1960-63 (Ser. 10, 4wd)
- Right hand
- PU6063-4665-FR4 each64.95**
- 1960-64 (Ser. 20/30 (1st Design - Rear))
- 1969-70 (Ser. 10 w/ Heavy duty brakes)
- Left hand
- PU6070-4665-FL each49.95**
- 1960-70 (Ser. 20/Ser. 30)
- 1969-70 (Ser. 10 w/ Heavy duty brakes)
- PU6070-4665-FR each49.95**
- 1964-70 (Ser. 10 - exc Heavy Duty)
- Left hand
- PU6470-4665-FL each44.95**
- 1964-70 (Ser. 10)
- Right hand
- PU6470-4665-FR each44.95**
- 1970 (Ser. 20, 4wd w/ front locking hubs)
- Left hand
- PU70-4665-FL each34.95**
- 1970 (Ser. 20, 4wd w/ front locking hubs)
- Right hand
- PU70-4665-FR each34.95**

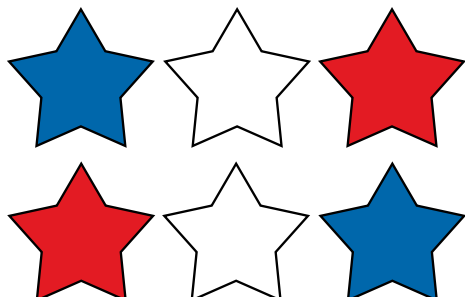

We accept Visa, Master Card, and Discover - Order Now!



TRANSMISSION & BRAKES

DOT 5



SILICONE BRAKE FLUID

This is the end of condensation in your brake system! No more internal rust!
All years/models with hydraulic brakes

M-2141-SBF each.....24.95

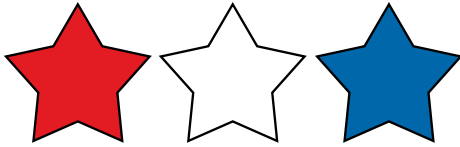

NEXT DAY AIR shipping available on any order

Nancy keeps our office under control with a smiling face!



FRONT BRAKE HOSE

1936-50 (2wd, Ser. 10)
1955-59 All (w/ 123 1/4" W.B.)
1938 T-1555
1939-42 All
1937-59 (2wd, Ser. 30)
1946-59 (2wd, Ser. 20- Rear)
1937-55 (2wd, Ser. 30)
1938-56 (2wd, Ser. 20)
1936-50 All

PU3859-4680-RA each.....29.95

1951-55 All (1st Series)
1955-59 All (w/ 114" W.B.)
front/rear brake hose

PU5559-4680-A each.....29.95

1957-59 (Ser. 20 (long wheel base))

PU5759-4680-A each.....24.95

1960-66 (2wd, Ser. 10)
1960-66 (2wd, Ser. 20/30)

PU6067-4680-A each.....29.95

1967 (2wd, Ser. 10-30, (exc w/ 11 Lb Axle))

PU67-4680-A each.....29.95

1968 (Ser. 10/20 - 2WD)

PU68-4680-A each.....21.95

1968-70 (2wd, Ser. 10/20)
1968-70 (2wd, Ser. 30 All (exc w/ Booster))

PU6870-4680-A each.....29.95

1971-72 All
Left hand

P7172-4680-AL each.....39.95

1971-72 All
Right hand

P7172-4680-AR each.....39.95

1971-72 (1/2 Ton, 2wd Pickup w/ Disc brakes)
For 1/2 ton Pickup

P7172-4680-AS pair.....49.95



REAR BRAKE HOSE

1951-55 All (1st Series)
1955-59 All (w/ 114" W.B.)
front/rear brake hose

PU5559-4680-A each.....29.95

1960 (Ser. 10 with 127" wheel base)

1960 (Ser. 20)

1960-66 (Ser. 30)

PU6066-4680-RA each.....19.95

1961-62 (Ser. 10 with 115" Wheel base)

PU6162-4680-RA each.....19.95

1963-66 (2wd, Ser. 10 w/ 127" W.B.)

1963-66 (2wd, Ser. 20)

PU6366-4680-RA each.....29.95

1963-66 (2WD, Ser. 10 w/ 113" Wheel base)

1964-66 (2wd, Ser. 10, All w/ 127" W.B. - 2nd Design)

PU6366-4680-RB each.....34.95

1960 (2wd, Ser. 10)

1967 (2wd, Ser. 20)

1968-69 (2wd, Ser. 20) 1968-70 (2wd, Ser. 10 w/ Coil springs)

1970 (2wd, Ser. 20, 127" WB (exc leaf springs & 396))

PU6770-4680-RA each.....34.95

1967 (Ser. 20 2WD with leaf springs)

1968-69 (Ser. 20 2WD with 127" wheel base without Leaf Springs or 396 motor)

1970 (Ser. 20 with leaf springs & 396 engine)

1968-70 (Ser. 10 w/ 396 Engine & Leaf Springs)

PU6770-4680-RB each.....21.95

1967-70 (2wd, Ser. 30)

1970 (4wd, Ser. 20)

1971-72 (3/4 Ton, 133" W.B.)

1971 (1 Ton)

PU6870-4680-RA each.....29.95

1971 (Ser. 10 with coil springs)

1971 (Ser. 20 with 127" wheel base & 396 engine)

PU71-4680-RDA each.....26.95

1971 (4wd, Ser. 10)

1971 (2wd, Ser. 20 w/ Leaf Springs)

1971 (2wd, Ser. 10 w/ Leaf Springs)

PU7172-4680-RDA each.....49.95



Be sure to stop by our store in Oklahoma City!



Brake Line Sets

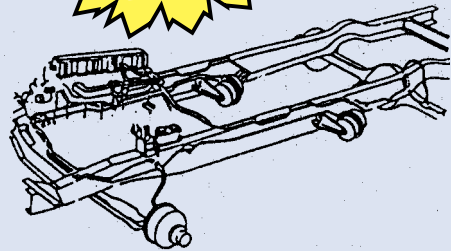

Brake line sets are special order. Please allow 2-3 weeks for delivery. Must be pre-paid.

- Bent to OEM specifications
- Correct color-coded fittings
- Fitting to match OEM specifications
- OEM machine double-flared
- Spiral wound armor guard used where required

When ordering, please specify the following:

1. Manual or power brakes
2. 2WD or 4WD
3. Short or long bed
4. 1/2 ton or 3/4 ton
5. Coil or leaf spring

BRAKE LINE SET

1947-50 Chevy Pickup (2wd Short bed), Manual Drum Brakes
Stainless steel. Includes every hard brake line on truck.

P4750-4685-SS kit239.95

1947-50 Chevy Pickup (Manual Drum Brakes) 2wd Short bed
Stainless steel

P4750-4685-S kit199.95

1951 Chevy Pickup (Manual Drum Brakes) 2wd Short bed
Plain Steel

P51-4685-S kit199.95

1951 Chevy Pickup (Manual Drum Brake Line set) 2wd Short bed
Stainless steel

P51-4685-SS kit239.95

1952 Chevy Pickup (Manual Drum Brakes) 2wd Short bed
Plain steel

P52-4685-S kit199.95

1952 Chevy Pickup (Manual Drum Brakes) 2wd Short bed
Stainless steel. includes every hard brake line on truck

P52-4685-SS kit239.95

1953 Chevy Pickup (Manual Drum Brakes) 2wd Short bed
Plain steel

P53-4685-S kit199.95

1953 Chevy Pickup (Manual Drum Brakes) 2wd Short bed
Stainless steel

P53-4685-SS kit239.95

1954-55 Chevy Pickup (Manual Drum Brakes) 2wd Short bed
Plain Steel

P5455-4685-S kit279.95

1954-55 Chevy Pickup (Manual Drum Brakes) 2wd Short bed
Stainless steel

P5455-4685-SS kit239.95

1955-56 Chevy Pickup (Manual Drum Brakes) 2wd Short bed
Plain steel

P5556-4685-S kit199.95

1955-56 Chevy Pickup (Manual Drum Brakes) 2wd Short bed
Stainless steel

P5556-4685-SS kit239.95

1957 Chevy Pickup (Manual Drum Brakes) 2wd Short bed
Plain steel

P57-4685-S kit199.95

1957 Chevy Pickup (Manual Drum Brakes) 2wd Short bed
Stainless steel

P57-4685-SS kit239.95

1958-59 Chevy Pickup (Manual Drum Brakes) 2wd Short bed
Plain steel

P5859-4685-S kit199.95

1958-59 Chevy Pickup (Manual Drum Brakes) 2wd Short bed
Stainless steel

P5859-4685-SS kit239.95

1960-62 Chevy Pickup
Plain steel. ***Must specify manual or power brakes, 2wd or 4wd, short or long bed***

P6062-4685-SSPO kit199.95

1960-62 Chevy Pickup
Stainless steel. ***Must specify manual or power brakes, 2wd or 4wd, short or long bed***

P6062-4685-SSSSPO kit239.95

1963-64 Chevy Pickup, 2wd
Plain steel. ***Must specify manual or power brakes, 2wd or 4wd, short or long bed***

P6364-4685-SSPO kit199.95

1963-64 Chevy Pickup, 2wd
Stainless steel. ***Must specify manual or power brakes, 2wd or 4wd, short or long bed***

P6364-4685-SSSSPO kit239.95

1965 Chevy Pickup, 2wd (Plain steel)
Plain steel. ***Must specify manual or power brakes, 2wd or 4wd, short or long bed***

P65-4685-SSPO kit199.95

1965 Chevy Pickup, 2wd
Stainless steel. ***Must specify manual or power brakes, 2wd or 4wd, short or long bed***

P65-4685-SSSSPO kit239.95

1966 Chevy Pickup
Plain steel. ***Must specify manual or power brakes, 2wd or 4wd, short or long bed***

P66-4685-SSPO kit199.95

1966 Chevy Pickup, 2wd
Stainless steel. ***Must specify manual or power brakes, 2wd or 4wd, short or long bed***

P66-4685-SSSSPO kit239.95

1969-70 Chevy/GMC
Plain steel. ***Must specify manual or power brakes, 2wd or 4wd, short or long bed, 1/2 ton or 3/4 ton, coil, leaf, or coil help springs***

P6770-4685-SSPO kit199.95

1967-70 Chevy/GMC
Stainless steel. ***Must specify manual or power brakes, 2wd or 4wd, short or long bed, 1/2 ton or 3/4 ton, coil, leaf, or coil help springs***

P6770-4685-SSSSPO kit239.95

1969-70 Chevy Blazer/ GMC Jimmy
Plain steel. ***Must specify manual or power brakes, 2wd or 4wd, short or long bed***

P6970-4685-SSPO kit199.95

1969-70 Chevy Blazer/GMC Jimmy
Stainless steel. ***Must specify manual or power brakes, 2wd or 4wd, short or long bed***

P6970-4685-SSSSPO kit239.95

1971-72 Chevy Blazer/GMC Jimmy
Plain steel. ***Must specify manual or power brakes, 2wd or 4wd, short or long bed, 1/2 ton or 3/4 ton, coil, leaf, coil help springs or dually springs***

P7172-4685-ASSPO kit199.95

1971-72 Chevy Blazer/GMC Jimmy
Stainless steel. ***Must specify manual or power brakes, 2wd or 4wd, short or long bed, 1/2 ton or 3/4 ton, coil, leaf, coil help springs or dually springs***

P7172-4685-ASSSSPO kit239.95

1971-72 Chevy/GMC
Plain steel. ***Must specify manual or power brakes, 2wd or 4wd, short or long bed, 1/2 ton or 3/4 ton, coil, leaf, coil help springs or dually springs***

P7172-4685-SSPO kit199.95

1971-72 Chevy/GMC
Stainless steel. ***Must specify manual or power brakes, 2wd or 4wd, short or long bed, 1/2 ton or 3/4 ton, coil, leaf, coil help springs or dually springs***

P7172-4685-SSSSPO kit239.95

1973-80 Chevy
Plain steel.

P7380-4685-ASSPO kit199.95

1973-80 Chevy
Stainless steel.

P7380-4685-ASSSSPO kit239.95

1973-80 Chevy/GMC
Plain steel. ***Must specify 2wd or 4wd, short or long bed, 1/2 or 3/4 ton***

P7380-4685-SSPO kit199.95

1973-80 Chevy/GMC
Stainless steel. ***Must specify 2wd or 4wd, short or long bed, 1/2 or 3/4 ton***

P7380-4685-SSSSPO kit239.95





TRANSMISSION & BRAKES



BRAKE PROPORTIONING VALVE

1971-72 Pickup
P7172-4690-A each139.95



REAR BRAKE CABLE

Runs from each rear drum to connect to the intermediate cable.
 1937 Early 47 Chevy Pickup
P3746-4779-RBC each.....39.95
 Late 47 to Early 55 -Chevy Pickup 1 Ton
PU5155-4779-RBC each34.95
 1955-59 (1 Ton exc Positraction - Req. 2)
PU5559-4779-RBC each39.95
 1960-62 (127" wheel base)
 Long bed 127" 1/2 ton only
P6062-4779-RBC each.....39.95
 1960-62 Pickup
 2wd only
PU6062-4779-RBC each34.95
 Early 1963 Chevy Pickup
 115" wheelbase (short bed)
P63-4779-RBC each.....39.95
 1963-65 (2wd, Ser.10, 115" WB - Req 2)
 Note late 63
PU6365-4779-RBC each34.95
 1963-65 (2wd, Ser. 10, 127" WB - Req. 2)
 Longbed
PU6365-4779-RBM each31.95
 1966-72 All
 1968-71 C10 with coil springs req 2 per truck
 (LH or RH) requires 2 per truck
P6672-4779-RBC each.....29.95
 1966-72 (3/4 Ton Rear 127" WB w/ Coils
 springs)
PU6672-4779-RBC each44.95
 1967-69 (1 Ton, 4wd, Req 2)
PU6769-4779-RBC each64.95
 1973-83 All
 (LH or RH)
P7383-4779-RBC each.....21.95

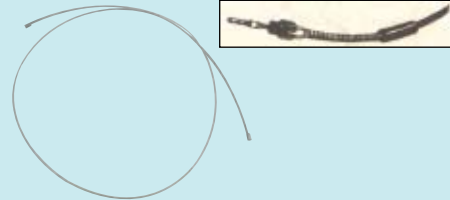

FRONT BRAKE CABLE

Cables go from the handle to the intermediate cable.
 1955-59 Ser. 10
 3100
PU5559-4779-FBC each.....24.95
 1955-59 Chevy
 Longbed 124 1/4"
PU5559-4779-FBCL each21.95
 1960-62 Chevy
 Long bed 127", 1/2 ton only
P6062-4779-FBCL each.....39.95
 1960-62 Chevy
 Fits short bed 115"
P6062-4779-FBCS each.....46.95
 1963 (1 Ton)
PU63-4779-FBC each.....39.95
 1964-65 (1 Ton)
 56-3/16" o.l.
PU6465-4779-FBC each.....39.95
 1966-68 (1 Ton)
 With coil
PU6668-4779-FBC each.....49.95
 1969-70 (2wd, Ser. 10, w/ Coil spring (exc 396
 Engine) or 115" WB w/ 396)
PU6970-4779-BCB each72.95
 1969-70 C10 115" WB coil springs exc. 396
 engine
PU6970-4779-BCM each69.95
 1969-70 C10 with 396 engine
PU6970-4779-FBC each.....34.95



INTERMEDIATE BRAKE CABLE

Connects to the two rear cables to the front cable.
 1966-68 - 2wd, Ser. 10 - 127" WB w/ Coil springs
 1969-70 - 2wd, Ser. 10 w/ 127" WB & Coil
 springs, exc 396
 1971-72 - 2wd, Ser. 10 w/ 127" WB w/ Coil
 springs, exc TH400
PU6668-4779-IBA each19.95
 1967-68 4wd, Ser. 10, 127" w.b
 1969-70 115" W.B. w/ Coil springs (exc 396)
PU6770-4779-IBA each26.95
 1968 - 2wd, Ser. 10, 115" WB , exc Leaf springs
PU68-4779-IBA each29.95
 1969 4wd, Ser. 10, 127" WB
PU69-4779-IBA each23.95
 1969 4wd, Ser. 10, 115" WB
PU69-4779-IBB each18.95
 1969-70 - C10 - 127" WB With 396
PU6970-4779-IBA each19.95
 1969-70 - 2wd, Ser 10, 115" WB w/ Coil Springs
 396
PU6970-4779-IBB each19.95



BRAKE PLATE ADJUSTING HOLE COVER

Rear flange plate
 1938-73 All
 1964-75 All
 1965-75 All
P3872-5117-A each1.95
 1974-84 2wd, 4wd, Ser. 10-30 Blazer, Jimmy
P7484-5117-A each1.95



BRAKE ADJUSTMENT HOLE PLUG SET

1947-59 Pickup
P4754-4800-PL set.....3.95



EMERGENCY BRAKE CLEVIS PIN

1947-54 Pickup
P4754-4823-A pair1.95
 1947-54 Pickup
 Yolk with pin. This is a shorter length 2 1/2",
 but will fit your system)
P4754-4823-AS each9.95



PARK BRAKE CABLE BOOT

1947-59 Pickup
P4754-4826-A each3.95



BACKING PLATE GASKETS

Emergency brake cable to backing plate gas-
 kets.
 1947-54 Pickup
P4754-4827-G set.....2.95



STARTER FLOOR SEAL

1939-46 Pickup
P3946-4834-A each9.95



**Don't forget the
 bolt kits!**

Here's
 Cindy,
 hard at
 work in the
 office...
 Service
 with a
 smile!





BLACKWALL FIRESTONE TIRE

- Pickup
600 x 16
P-5000-60016 each132.95
- Pickup
670 x 15
P-5000-67015 each132.95
- Pickup
775 x 15
P-5000-77515 each134.95

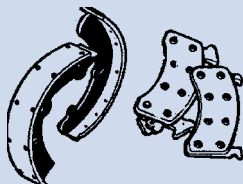

BRAKE SHOE SET

- 1951-63 Front Brake Shoes 1/2 & 3/4 Ton
1959-63 Rear Brake Shoes 2wd, 4wd, Ser. 10
PU5163-5017-FA set44.95
- 1960-70 (2wd, Ser. 20 w/ Coil Springs)
1965-70 (2wd, Ser. 20 w/ Leaf Springs)
1967-69 Front Brake Shoes 2wd, Ser. 10, Heavy Duty
PU6070-5017-A set46.95
- 1964-68 (2wd, Ser. 10 Front)
1964-68 (4wd, Ser. 10 Rear)
1964-68 (2wd, Ser. 10 Rear)
1965-70 Front brake shoes 4wd, (C10)
1967-70 C10
1967-70 (2wd, Ser. 10 Front)
1967-70 (4wd, Ser. 10 Heavy Duty -Rear)
1967-70 (2wd, Ser. 10, Except Heavy Duty -Rear)
PU6470-5017-A set42.95
- 1976-83 All
Rear brake shoe
P7683-5017-RA each44.95



1964-71

1964-72



1971-72

BRAKE HARDWARE KIT

- 1964-71 Pickup (For front brakes. Contains all springs, pins, hold downs, and adjuster screw, for drum brake only.)
P6471-5026-FBK kit64.95
- 1964-72 Pickup (For rear brakes. Contains all springs, pins, hold downs, and adjuster screw, does 2 wheels.)
P6472-5026-FBK kit59.95
- 1971-72 Pickup (For front brakes. Contains bolts, clips, and correct o-rings, for disc brakes only.)
P7172-5026-FBK set44.95



1960-70

REAR AXLE CONTROL ARM BUSHING

- 1960-70 Ser 10-20 (exc leaf springs, 2 3/4 o.d.)
P6072-5381-A each14.95

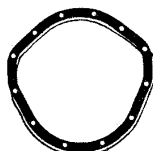

REAR AXLE HOUSING COVER GASKET

- Dana 34685 - 10 bolt differential cover
1958-59 (1 Ton w/ positraction)
1960-69 (4wd)
1966-68 w/ Leaf spring
1969-72 (4wd, Blazer)
1979-80 (4wd Ser. 10, 20 (w/ Dana)
P5872-5399-A each9.95
- 1963-72 Ser. 10 (All) & Blazer
P6372-5399-A each10.95
- 1979-84 (2wd, 4wd, Ser. 30 (w/7500 lb axle)
P7984-5399-A each14.95



1960-72



1960-72, urethane

REAR TRACKING ARM BUSHING

- 1960-72 (1/2 Ton Pickup (exc big block or 4wd)
P6072-5417-A each16.95
- 1963-70 (3/4 Ton & all w/ 396 CU in engines (exc leaf springs)
P6370-5417-A each29.95



DRIVE SHAFT CENTER BEARING ASSEMBLY

- Used with all pickups w/ coil springs.
1955-72 All with coil springs
P5572-5544-A each27.95
- 1955-72 Pickup with coil spring (polyurethane)
P5572-5544-P each109.95
- For pickups with leaf springs.
1955-80 All with leaf springs
P5580-5544-A each27.95



U-JOINT BALL GASKET & SEAL SET

- 1947-54 Pickup
P4754-5560-SK kit14.95



U-JOINT BOLT KIT

- 1947-54 Pickup
P4754-5586-A kit2.95



Gotta tough question?
Joe is ready to help!

We appreciate your business!



BRAKES, REAR AXLE, DRIVESHAFT, WHEELS

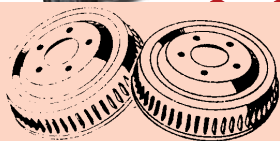

FRONT BRAKE DRUM

Includes 6 studs. Excellent reproduction.
1936-50 Pickup (1/2 Ton)

P3650-5809-A each112.95

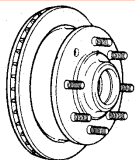

FRONT BRAKE ROTOR

1971-80 All

P7180-5809-A each59.95

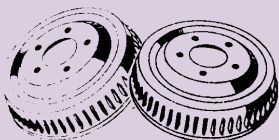

REAR BRAKE DRUM

1971-86 All with 11" X 2" Brake

P7186-5809-A each79.95



FRONT WHEEL STUD

1936-50 Pickup (1/2 Ton)

P3650-5812-A each3.95



**Order
with
confidence!**



HUB BOLT

7/16" - 20 x 1-5/8". Req. 12 per vehicle.

1938-42 All

1946-59 10 Ton (exc. p/trac)

1951-62 Ser 10 (exc. p/trac)

1960-62 Ser 10 (rear)

1963-70 Ser 10, 4wd

1969-70 Blazer (front)

1963-64 Ser 20, 4wd (rear)

P5170-5812-A each11.95

Front, 33/64" dia. serrated shoulder - 3/4 head

dia. (1/2" - 20 x 1-41/64")

1960-70 3/4 & 1 Ton w/ dual rear wheels

P6070-5812-A each4.95

Front

1979-84 4wd, Ser. 10

F6981-5812-A each1.95

Front, 1/2" - 20 x 1-7/8"

1971-72 Ser 10 w/disc brakes (exc. 4wd)

1973-84 2wd, Ser. 20, Blazer, Jimmy

P7172-5812-A each5.95

Front, 7/16" - 20 x 2"

1971-72 Ser 10 (4wd), Blazer

1973-84 4wd, Ser 20, Blazer, Jimmy

P7172-5812-B each6.95



HUB BOLT NUT

1938-72 All

1967-70 All

1969-72 Blazer

1978-80 All

7/16" - 20

P3872-5813-A each1.95

1946-49 Comm w/ dual wheels

1/2" - 20, req. 32 per vehicle

P4649-5813-A each1.95

1955-70 10/20 Ton w/ single wheels

1973-78 2wd, Ser 10, Blazer, (exc rally wheel,

styled wheels)

1979-84 2wd, 4wd- Ser 10/30

1/2" - 20 wrench size 13/16". Req. 32 per

vehicle.

P5570-5813-A each4.95



STAINLESS STEEL CAPPED LUG NUT FOR SUPER SPORT WHEEL

1979-82 K1

A6972-5813-SS each1.95



SMOOTH STYLE WHEEL TRIM RING

Polished stainless steel, narrow style.

All

15"

P-5803-15 each24.95

16"

P-5803-16 each26.95



HUB CAP WHEEL CLIP

High temp. spring steel.

1936-60 Pickup

P3660-5871-CLP each1.95



WHEEL TRIM RING SET, CHROME PLATED

All

14" x 6"

A6472-5871-146C set34.95

All

14" x 7"

A6472-5871-147C set59.95

All

15" x 6"

A6472-5871-156C set34.95

All

15" x 8"

A6472-5871-158C set59.95



**ORDER
NOW!**

BRAKES, REAR AXLE, DRIVESHIFT, WHEELS



WHEEL TRIM RING SET, STAINLESS STEEL

- All
14" x 6"
A6472-5871-146S set54.95
15" x 6"
A6472-5871-156S set54.95
15 x 7"
A6472-5871-157S set of 489.95
15" x 8"
A6472-5871-158S set89.95



1974-76



1977-78

WHEEL COVER INSERT

- 1974-76 (2wd, Ser 10 Blazer w/ rally wheels (Chevy only)
1978-84 (2wd, Ser 10, Rally & styled (Chevy only)
P7484-5871-A each24.95
1974-76 (2wd, Ser 10, Jimmy w/ rally wheels (GMC only)
1978-84 (2wd, Ser 10, Rally & styled)
P7484-5871-B each24.95
1977-78 (4wd, Ser 10 Rally & styled)
4" x 4", rear wheels only.
P7778-5871-C each27.95



bowtie



red crown



gold crown

WHEEL VALVE STEM CAPS

- All
With bow-tie logo.
M-5875-BT set of 415.95
With GMC logo.
M-5875-GMC set of 415.95
Gold crown
M-5875-GVC set of 58.95
Red crown
M-5875-RVC set of 58.95
With red, white, & blue bow-tie logo.
M-5875-RWB set of 415.95



1941-46



1947-53



1947-55



1954-55



1955-56



1964-66

CHROME HUBCAP

- 1936-45 Ser. 2 Pickups (GMC only)
1936-46 Ser. 1 Pickups (GMC only)
P3646-5858-B each39.95
1940 Ser. 10
Chrome with red and blue painted details.
P40-5858-A each64.95
1941-46 (1 Ton Pickup) (Chrome with red and blue painted details, just like the original.)
P4146-5858-A each39.95
1947-53 (Ser. 10 only Pickup)
With red painted block letters. Just like the originals.
P4753-5858-A each29.95
1947-53 Ser. 20 3/4 ton Pickup
Chrome with red block letters
P4753-5858-B each79.95
1947-55 1/2 ton, GMC pickup (W/ red painted details)
P4755-5858-B each39.95
1947-55 GMC pickup Ser. 10
With white painted block letters.
P4755-5858-C each39.95
1954-55 (Ser. 10 Pickup) (W/ blue painted bowtie.)
P5455-5858-A each39.95
1955-56 (Ser. 10 Pickup) (W/ ivory painted bowtie)
P5556-5858-A each59.95
1955-59 GMC Pickup (With red lettering.)
P5559-5858-A each64.95
1957-60 Pickup (With black lettering.)
P5760-5858-A each59.95
1957-90 Ser. 10/20 Ton Pickup (Nice reproduction.)
P5760-5858-B each74.95
1964-66 Ser. 10 (With red bowtie. 15" wheels w/ bumps to hold cap on wheel. Will not fit wheels with clips, exact reproduction.)
P6466-5858-A each64.95

CHEVROLET^{AVE.}

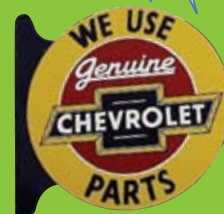

*Find these great items
in our Accessories &
Decals section!*



Take some time to
check out our website!
Order your
parts online or
order one of our
useful catalogs!

www.classicchevroletparts.com



FRONT SUSPENSION & STEERING



STEERING IDLER ARM ASSEMBLY

- 1960-62 (2wd, Ser. 10)
- 1960-66 (2wd Ser. 20, 30)
- PU6066-6103-A each149.95**
- 1963-66 (1/2 Ton 2WD)
- PU6366-6103-A each49.95**
- 1967-82 (1/2 Ton thru 1 Ton 2WD)
- PU6782-6103-A each29.95**
- 1971-82 Blazer (2WD)
- P7182-6103-A each34.95**



FRONT AXLE BUMPER

- 1947-54 Chevy Pickup (1/2 Ton)
- P4754-6164-AS each5.95**



CONTROL ARM BUSHING

- 1960-62 Ser. 10-20 (exc. D-D & 4wd)
- 1963-69 Ser. 20-30 (exc. D-D & 4wd)
- 1968-72 Ser. 20-30 (D-D)
- 1973-84 (2wd Ser. 20, 30)
- Upper arm bushing.
- P6072-6164-BSH each14.95**
- 1973-82 (1/2 Ton Blazer (2WD))
- 1973-87 (1/2 Ton (2WD) - requires 4)
- Upper arm bushing.
- PU7386-6164-UCAB each8.95**
- 1963-67 (1/2 Ton (2WD))
- 1968-72 Exc. 4wd & D-D
- 1973-84 (3/4 Ton & 1 Ton (2WD))
- Lower arm bushing.
- P6372-6170-BSH each15.95**
- 1964-69 (1/2 Ton (2WD))
- 1970-72 (1/2 Ton (Conv & D-D) & Blazer)
- Lower arm bushing.
- P6472-6164-BSH each17.95**
- 1973-78 Blazer & Jimmy (2WD)
- 1979-82 (1/2 Ton (2WD))
- Upper arm bushing.
- P7382-6164-BSH each16.95**
- 1973-82 (2wd, C10 Blazer)
- 1973-86 (2wd, Ser. 10 requires 4)
- Lower arm bushing.
- PU7386-6170-LCAB each10.95**

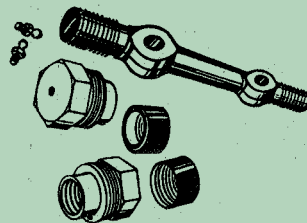

UPPER CONTROL ARM SHAFT KIT

- 1963-86 (2wd, Ser. 20, 30 - requires 2)
- PU6086-6164-UA each44.95**
- 1963-72 (1/2 Ton (2WD) - requires 2)
- PU6372-6164-UA each39.95**
- 1973-86 (1/2 Ton (2WD) - requires 2)
- PU7386-6164-UA each44.95**



LOWER CONTROL ARM SHAFT BUSHING SEAL

- Requires 4 per truck.
- 1963-72 All 1/2, 3/4, and 1 Ton Pickups
- 1973-84 (3/4 and 1 Ton Pickups)
- P6372-6166-L each5.95**



LOWER BALL JOINT

- 1960-62 (1/2 Ton & 3/4 Ton 2WD)
- PU6062-6168-B each179.95**
- 1963-70 (1/2 Ton 2WD)
- 1970 Blazer 2WD
- PU6370-6168-B each29.95**
- 1971-86 (1/2 Ton 2WD)
- PU7186-6168-B each29.95**



UPPER BALL JOINT

- 1960-62 (2WD, Ser. 10)
- 1963-70 (2WD, Ser. 20/30)
- PU6070-6168-A each59.95**
- 1963-70 (1/2 Ton (2WD))
- 1970 Blazer (2WD)
- PU6370-6168-A each24.95**
- 1971-72 (1/2 Ton (2WD) with disc brakes)
- 1971-72 Blazer (2WD)
- PU7172-6168-A each59.95**
- 1973-82 Blazer (2WD)
- 1973-86 (1/2 Ton (2WD))
- PU7386-6168-A each36.95**



LOWER CONTROL ARM SHAFT KIT

- 1963-72 (1/2 Ton (2WD))
- 1967-86 (3/4 Ton & 1 Ton (2WD))
- PU6086-6169-LA each54.95**



UPPER CONTROL ARM BUMPER

- 1960-72 Ser. 10-30 (exc. D-D & 4wd)
- P6072-6176-BM each5.95**



KING BOLT SET

- 1946-52 (1/2 & 3/4 Ton (exc. double duty))
- PU4652-6203-A set64.95**
- 1947-55 (1/2 Ton)
- PU4755-6203-A set39.95**
- 1955-59 (1/2 Ton)
- PU5559-6203-A set44.95**



TIE ROD ADJUSTING SLEEVE

- 1960-64 (1/2 Ton 2WD)
- P6064-6232-A each19.95**
- 1965-70 (1/2 Ton 2WD with power steering)
- 1965-70 (1 Ton 2WD)
- 1967-70 (3/4 Ton 2WD with power steering)
- PU6568-6232-AS each24.95**
- 1965-70 (1/2 Ton to 1 Ton 2WD no power steering)
- 1969-70 (1 Ton 2WD) all
- PU6570-6232-AS each12.95**
- 1971-86 (1/2 Ton 2WD)
- 1971-87 (1/2 Ton 2WD)
- 1971-88 (1 Ton 2WD)
- 1971-82 Blazer 2WD
- 1973-86 (1/2 Ton 2WD)
- PU7186-6232-AS each10.95**



FRONT SUSPENSION & STEERING



TIE ROD END REPAIR KIT

Does both ends.
1929-59 (1/2 & 3/4 Ton)
P2959-6233-AS kit44.95



TIE ROD ENDS

1947-59 Chevy/GMC
P4759-6233-PR pair79.95



OUTER TIE ROD END

1960-62 (2wd, Ser. 10)
Fits either side
PU6062-6233-A each26.95
1960-64 (2wd, Ser. 20)
Fits either side
PU6064-6233-A each29.95
1963-64 (2wd, Ser. 10)
Fits either side
PU6364-6233-A each29.95
1965-70 (2wd, Ser. 10)
1970 (2wd, Blazer)
Fits either side
PU6570-6233-A each19.95
1965-70 (2wd, Ser. 20/30)
Fits either side
PU6570-6233-ARL each36.95
1971-72 (2wd, Ser. 10)
1971-72 (2wd, Blazer)
Fits either side **also inner**
PU7172-6233-A each24.95
1971-72 (2wd, Ser. 30)
1971-86 (2wd, Ser. 20)
1973-82 (2wd, Ser. 10 Blazer)
1973-86 (2wd, Ser. 10/30)
Fits either side
PU7186-6233-A each24.95



TIE ROD END URETHANE DUST COVER BOOTS

1947-86 All 1/2 Ton 2 Wheel Drive
B5572-6233-B pair5.95



INNER TIE ROD

Fits either side
1963-64 (1/2 Ton 2WD)
PU6364-6233-B each34.95
1965-70 (1/2 Ton 2WD)
1970 (2wd, Blazer)
P6570-6233-A each19.95
1971-86 (1/2 Ton 2WD)
1973-86 (1/2 Ton 2WD)
1973-82 (2wd, Ser. 10 Blazer)
PU7186-6233-B each24.95



TIE ROD REPLACEMENT BALL SET

1947-52 Pickup (Threaded type)
P4752-6243-AS set of 469.95
1947-59 Pickup (Tapered fit)
P4759-6243-AS set.39.95



FRONT WHEEL INNER BEARING

1960-62 (2wd, Ser. 20/30)
PU6062-6311-IB each69.95
1962-86 (1/2 Ton 2WD)
PU6286-6311-IB each9.95
1963-70 (2wd, Ser. 20/30)
1969-70 (2wd, Ser. 10 Blazer H.D. drum brakes)
PU6370-6311-IB each29.95



FRONT WHEEL OUTER BEARING

Ball type, consists of cone, cup & separator
1944-57 All
1947 All
PU4257-6313-A each56.95
1953-59 (2wd, Ser. 20)
PU4659-6313-A each59.95
1960-62 (2wd, Ser. 10)
1962-68 (2wd, Ser. 10)
1969-70 (2wd, Ser. 10 & Blazer (exc. H/D))
PU6070-6313-A each6.95
1963-70 (2wd, Ser. 20)
1969-70 (2wd, Ser. 10 ,Blazer h/duty)
1971-94 (2wd, Ser. 10)
PU6370-6313-A each8.95
1971-91 (2wd, Ser. 20)
PU7187-6313-A each24.95



FRONT WHEEL INNER GREASE SEAL

1942 All
1944-59 (2wd, Ser. 10)
PU42-6326-A each16.95
1946-62 (2wd, Ser. 20, Ser. 30)
PU4662-6326-A each39.95
1962-68 (2wd, Ser. 10)
1969-70 (2wd, Ser. 10 (ex. h/duty))
PU6270-6326-A each14.95
1963-93 (2wd, Ser. 30)
1968-91 (2wd, Ser. 20)
1969-70 (2wd, Ser. 10 H/duty)
PU6393-6326-A each4.95
1971-86 (2wd, Ser. 10, Blazer)
PU7186-6326-A each4.95
1979-81 (2wd, Ser. 10)
F7081-6326-A each8.95

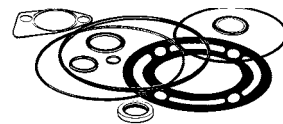

HYDRAULIC STEERING SMALL PARTS KIT

1963-68 Ser. 10-30 (exc. D-D & 4wd)
1968 Ser. 20-30 (D-D)
Cylinder, piston rod seal.
P6368-6507-A kit24.95
1963-68 Ser. 10-30 (exc. D-D & 4wd)
Control adapter valve seal & washer. Consists of 2 seals, 1 'o' ring and 1 nut.
P6368-6507-B kit19.95



HYDRAULIC STEERING SEAL KIT

Major repair kit.
1968-69 Ser. 10-30 (exc. 4wd & D-D)
1970 Ser. 10-30 (w/pwr steering)
1971-78 All & Blazer
P6872-6507-A kit99.95





FRONT SUSPENSION & STEERING

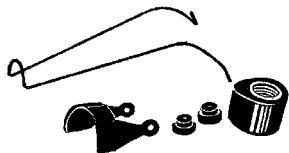

COLUMN SHIFT LEVER RETAINING PINS, SPRING, & BUSHING

1947-59 Pickup
P4759-6514-A each 9.95

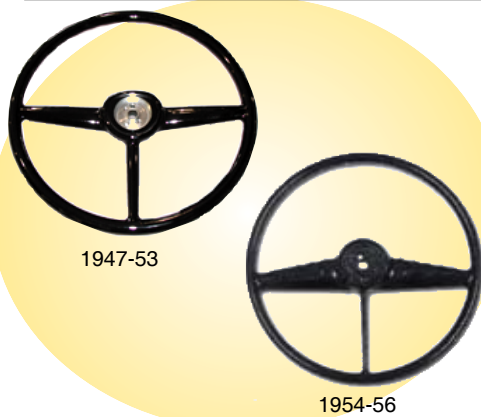

BLACK STEERING WHEEL

Outstanding replica of the original 1947-53 steering wheel. Black only.
1947-53 Chevy Pickup
P4753-6513-BLK each 199.95
1954-56 Chevy Pickup
P5456-6513-BLK each 199.95
1957-60 Chevy Pickup
P5760-6513-BLK each 199.95
1960-66 Chevy Pickup
P6066-6513-BLK each 199.95
1967-68 Chevy Pickup
P6768-6513-BLK each 199.95



COMFORT GRIP STEERING WHEEL KIT

Black. Comes complete with hub and horn assembly.
1967-72 Chevy/GMC Pickup, Blazer, Suburban
F69-6513-CGK kit. 299.95



STEERING WHEEL

1969-72 Chevy/GMC
Black
P6972-6513-BK each 159.95
1969-72 Chevy/GMC
Blue
P6972-6513-BL each 159.95
1969-72 Chevy/GMC
Dark blue
P6972-6513-DB each 159.95
1969-72 Chevy/GMC
Green
P6972-6513-G each 159.95
1969-72 Chevy/GMC
Saddle
P6972-6513-S each 159.95

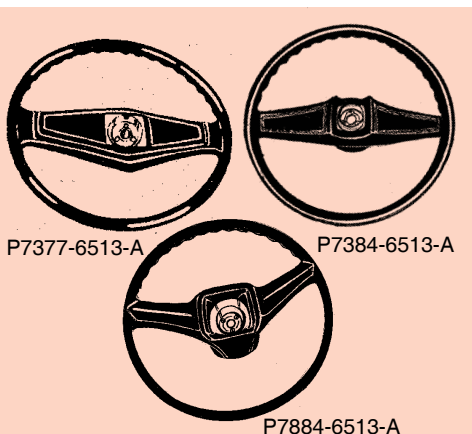

STEERING WHEEL

1973 (1/2 Ton thru 1 Ton)
1973-77 Blazer, Jimmy
1973-77 (1/2 Ton thru 1 Ton 4WD without Power Steering)
4 27/32" hub dia., 17 1/2"
P7377-6513-A each 239.95
1973-84 (1/2 Ton thru 1 Ton)
1977 (2wd, 4wd - Ser. 10-30, Blazer, Jimmy w/ custom steering wheel)
Black, 16", 4 1/8" hub dia.
P7384-6513-A each 239.95
1978-84 (2wd, 4wd, Ser. 10-30, (Exc. custom wheels)
P7884-6513-A each 239.95



See Street Rod section for other steering columns!

REBUILT TILT STEERING COLUMN

1967-72 Chevy Pickup
P6772-6518-T each 599.95
1973-76 Chevy Pickup
P7376-6518-T each 399.95
1977-78 Chevy/ GMC Pickup
P7778-6518-T each 399.95
1979-80 Chevy Pickup
P7980-6518-T each 399.95



STEERING SHAFT COUPLER (RAG JOINT) REPAIR KIT

Complete with flexible joint and mounting hardware.
1960-81 Chevy/GMC Pickups
P6081-6525-RK kit 9.95



STEERING SHAFT COUPLER (RAG JOINT)

1969-76 Pickup (w/ power steering)
X6776-6525-A each 69.95



COLUMN MOUNT PADS

1954 Pickup
P54-6556-MP kit 2.95



STEERING COLUMN FLOOR SEAL

Rubber
1936-46 Pickup (3 or 4 speed)
P3646-6758-S each 7.95

See Street Rod
for more Steering
Wheels!

FRONT SUSPENSION & STEERING



FASTENER

1938-70 All (steering column jacket fastener)
 1947-54 All
 1955-65 All (dash panel mat plastic fastener)
P3870-6758-F each 4.95



1947-55



1947



1948-55



1955-59



1967-72

STEERING COLUMN FLOOR SEAL

With toe pad sponge (3-speed).
 1947-55 (1st Series) Pickup
P4755-6758-A each 15.95
 1947 Pickup (3 Speed)
 1948-55 Pickup (4 speed)
P4755-6758-TFS each 15.95
 1948-55 Chevy/GMC Pickup
P4855-6758-3SP each 5.95
 1955-59 Pickup
P5559-6758-A each 15.95
 1967-72 Truck
P6772-6758-FS each 4.95
 1967-72 Pickup
P6772-6758-LA each 9.95

STEERING COLUMN SEAL RETAINING RING



1967-72 Pickup
P6772-6758-R each 9.95



UPPER STEERING COLUMN SEAL

Seal at the dash.
 1967-72 Pickup
P6772-6758-UA each 5.95



PITMAN SHAFT BUSHING

1938-72 All
 1-1/8" id x 1-3/8"
P3872-6786-A each 19.95
 1968-69 Ser. 10-30
 1-1/4" id x 1-5/8" od x 1-1/4" o.l.
P6869-6786-A each 42.95
 1971-72 All, Blazer w/power steering
 1973-84 2wd, 4wd, Ser. 10-30, Blazer, Jimmy
 w/power steering
P7072-6786-A each 49.95



REBUILT MANUAL STEERING GEAR BOX

Each must have year of truck, must know 3 or 4 speed. \$100.00 core charge required or we must receive rebuildable core before rebuilt steering box will be shipped.
 1947-72 Chevy or GMC Pickup
P4772-6803-MSPO each 244.95
 1947-72 Chevy GMC Pickup w/ power steering
P4772-6803-PSPO each 249.95



STEERING BOX REBUILD KIT

Includes bearings, bushings, ball bearings, adj. bolt, gasket & instructions, everything needed to rebuild your steering box.
 1955-59 (2nd Ser) Pickup
P5559-6803-RK kit 144.95



STEERING GEAR SEAL

1960-72 All without Power Steering
P6072-6806-A each 14.95



STEERING GEAR WORM BEARING ADJUSTING PLUG SEAL KIT

1973-77 All, Blazer, Jimmy w/ ps
 1978 (2wd, 4wd, Ser. 10-30 w ps)
 Use w/large diameter stub shaft. Date code on side cover includes letter I.
F7679-6840-A each 49.95
 1979-84 (2wd, 4wd, Ser. 10-30)
 Use w/small diameter stub shaft valve. Date code stamping on side cover of gear does not include the letter I.
F7981-6840-A each 24.95

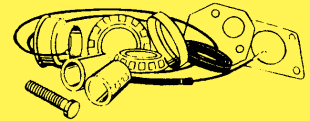

STEERING BOX OVERHAUL KIT

With instruction book & balls. Includes all ball bearings, seals, braces, and gaskets to overhaul gearbox.
 1947-59 Pickup
P5559-6500-SOK kit. 139.95



PITMAN ARM ASSEMBLY

1960-66 (2wd, Ser. 10-30)
PU6066-6859-A each 119.95
 1968-72 (2wd, Ser. 10-30 w/ ps)
 1969-72 (2wd, Blazer)
PU6872-6859-A each 69.95
 1969-72 (2wd, Ser. 10-30 w/ out ps, Blazer)
PU6972-6859-A each 59.95
 1973-82 (2wd, Ser. 10 Blazer)
 1973-86 (2wd, Ser. 10-30 w/out ps)
PU7386-6859-A each 59.95
 1973-82 (2wd, Ser. 10 Blazer)
 1973-86 (2wd, Ser. 10-30 w/ ps)
PU7386-6859-B each 42.95



PITMAN ARM NUT

1970-72 All, Blazer (w/ ps)
 1973-84 (2wd, Ser. 10-30, Blazer, Jimmy, (exc. ps)
P7072-6861-A each 10.95



CENTER DRAG LINK ASSEMBLY

Complete with ends.
 1937-46 Pickup
P3746-6870-A each 99.95
 1947-52 Pickup
P4752-6870-A each 99.95



STEERING CONTROL ROD BALL STUD SEAL

Requires 4
 1965-66 Ser. 10-20 (4wd)
 1967-68 Ser. 10, 4wd
 1967-69 Ser. 20-30
 1970-72 Ser. 20-30 (D-D)
 1973-84 (2wd, Ser. 10-30 Blazer, Jimmy (Reg 2)
P6572-6886-A each 11.95



FRAMES, SPRINGS, SHOCKS, BUMPERS



SWAY BAR BUSHING

- 1964 (1/2 Ton - 1 Ton (2WD))
PU6064-7243-SBB each5.95
 1965-67 (1/2 Ton - 1 Ton (2WD))
PU6567-7243-SBB each5.95
 1971-72 (2wd, Ser. 20/30)
 1971-86 (2wd, Ser. 10 Arm & frame)
 1973-86 (2wd, Ser. 20/30 w/ 1 1/16" Bar dia.
 arm & frame
PU6886-7243-SBB each8.95



FRONT STABILIZER BUSHING

- Requires 4.
 1968-70 Ser. 10/30 (exc. 4wd)
 1973-76 Ser. 10/20 Blazer, Jimmy (4wd - exc.
 H.D. stab, bar)
 1973-84 Ser. 10/30 (2wd - with front stab bar)
P6772-7243-A each6.95



STABILIZER LINK RETAINER

- 1938-69 Ser. 10-30, Blazer
P3869-7245-A each95



SHOCK ABSORBER LINK

- 1930-49 Pickup (Rear Shock)
 1947-49 Pickup (Front Shock)
P3049-7345-A each29.95
 1940-46 (Front shock only)
P4046-7345-A each29.95



SHOCK LINK BUSHING KIT

- Includes bushings, pins & sleeves.
 1930-49 Pickup
P3049-7345-BK set12.95

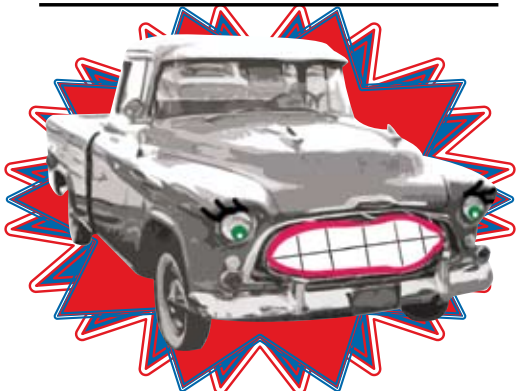

FRONT SHOCK ASSEMBLY FOR 1/2 AND 3/4 TON PICKUPS

- 1950-55 1st Ser. Chevy/GMC Pickup
P5054-7345-F each34.95
 1955-59 Chevy/GMC 1/2 and 3/4 Ton Pickups
P5559-7345-F each34.95
 1960-62 Chevy/GMC Pickup
P6062-7345-F each44.95



REAR SHOCK ABSORBER

- 1950-55 1st Ser. 1/2 Ton Pickups
P5054-7345-R each34.95
 1950-55 1st Ser. Chevy/GMC 3/4 ton Pickups
P5054-7345-R34 each34.95
 1955-56 Chevy/GMC 1/2 Ton Pickups
P5556-7345-R each34.95
 1955-56 Chevy/GMC 3/4 Ton Pickup
 1957-59 Chevy/GMC 1/2 and 3/4 Ton Pickup
P5559-7345-R each44.95



MUFFLER BRACKET GROMMET

- 5/8" id x 1-1/4" o.l., Requires 4 per vehicle.
 1950-55 exc 1
 1955-62 D-D & 1 ton exc 102" wb
 1968 (396)
 1968-70 Ser 10 (ffc w/ leaf spring)
 1969-72 (8 Cyl w/rear leaf springs)
P6772-7377-G each1.95

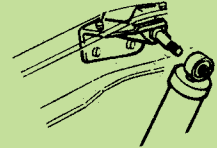

REAR SHOCK ABSORBER BRACKET

- 1967-72 Pickup
 Lower Left hand.
P6772-7380-LL each24.95
 1967-72 Pickup
 Lower Right hand.
P6772-7380-LR each24.95



SHOCK ABSORBER GROMMET

- Use on all bayonet type shock absorbers using
 1" id taper hole.
 1971-72 All, Blazer
P7172-7388-A each5.95



FRONT SPRING U-BOLT

- 1940-54 Pickup (1/2 Ton)
 Holds leaf spring to axle. Requires 2 per spring.
P4054-7417-A each10.95
 1955-59 Pickup
 (Short)
P5559-7417-A each10.95



FRONT SPRING BUMPER

- Requires 2.
 1971-72 Ser 10-20 (4wd & Blazer, 4wd)
 1979-84 (4wd, Ser. 30)
P7172-7422-A each12.95



SPRING SHACKLE RUBBER SEALS

- 1947-59 Pickup
P4754-7436-RB each1.95



REAR SPRING/AXLE SIDE PAD

- 1947-54 Pickup
P4754-7503-SP set of 46.95

Show off your truck!

Give your baby the TLC it deserves with our great selection of items!

FRAMES, SPRINGS, SHOCKS, BUMPERS



BLACK SPRING ANTI-SQUEAK POLY

Comes in 20 ft. roll. Fits between spring leaves. (1-3/4")

- U-7504-P** each9.95
(2-1/4")
- U-7504-PA** each13.95
(2")
- U-7504-PB** each11.95

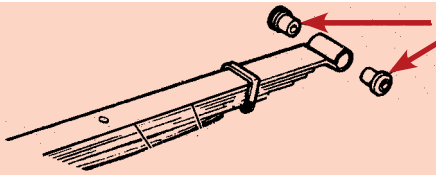

EYE PIN & BUSHING

Front or rear spring eye pin and bushing for one spring.

1947-54 Pickup

- P4754-7504-A** set.29.95



REAR SPRING BUSHING

1973-80 (2wd, 4wd, Ser. 10-30, Blazer, Jimmy)
3" o.l. x 1 1/2" thick

- P7380-7504-B** each26.95
- 1973 (2wd, Ser. 20, Blazer, Jimmy)
- 1973 (2wd, Ser. 10 (Tdr, sub w/ h.d. rear spring)
- 1973 (2wd, Ser. 10, Blazer, Jimmy (exc. h.d. rear spring)
- 1973-74 (2wd, Ser. 30 (w/ aux spring)
- 1973-74 (2wd, Ser. 30)
- 1973-74 (2wd, 3Ser. 0, (Fdr, exc aux rear spring)
- 1975-78 (2wd, 4wd, Ser. 20/30 (Cab, tdr, sub, w/ h.d. rear spring)
- 1979-84 (2wd, 4wd, Ser. 20/30)
- 9/16" i.d. x 21 13/64" o.d. x 3" o.l.
- P7384-7504-A** each36.95

Check Street Rod for Urethane Bushing Kits!



SPRING CENTER BOLT

1938-70 All, Blazer
1977-78 (2wd, 4wd, Ser. 10-30, Blazer, Jimmy)
Front or rear spring center bolt. Plain head (5/16" - 24 x 3-5/8") - Requires 2.

- P3870-7506-A** each11.95
- 1967-72 Ser 10-20 (4wd) w/ heavy duty front spring
- 1973-78 (4wd, Ser. 10, 20, Blazer, Jimmy w/ h.d. front spring)
- 1977-78 (4wd, Ser. 30)
- Front spring center bolt. (5/16" - 20 x 1-7/8") - Requires 2.

- P6772-7506-A** each2.95
- 1969-72 Ser 10 w/ rear leaf spring
- 1973-76 (2wd, Ser. 10 (Cab, Blazer, Jimmy) exc. h.d. rear springs)
- 1975-76 (2wd, Ser. 10, (Sub, 250)
- 1977-78 (2wd, Ser. 10, exc. h.d.)
- Rear spring center bolt. (1-24 x 2) - Requires 2.
- P6972-7506-B** each4.95



STEEL U-BOLTS

For rear spring, includes nuts. Fits on leaf springs.

- 1937-46 Pickup (1/2- 3/4 Ton rear)
- P3746-7516-AS** each14.95
- 1940-55 (1st Ser (C10-C20 Front)
- 1947-55 (1st Ser (C10 Rear)
- P4055-7516-AS** each10.95
- 1955-59 Pickup (rear)
- (Long) holds leaf spring to axle. (Req. 2 per spring)
- P5559-7516-A** each11.95



REAR SPRING U-BOLT NUT

- 1949-59 (1/2 Ton, All)
- P4959-7516-N** each3.95

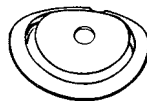

REAR COIL SPRING CLAMP

- Upper and lower
- 1960-72 Ser 10-20
- P6072-7518-CL** each9.95



FRONT SPRING SHACKLE KIT

Requires 2 per spring.
1934-46 Pickup (C10 & C20)

- PU3446-7523-A** kit39.95
- 1947-55 Pickup
- PU4755-7523-A** kit39.95



REAR SPRING SHACKLE KIT

Requires 2 per axle.
1934-46 Pickup (1/2 Ton)

- PU3455-7523-A** kit39.95
- 1947-55 Ser. 1/2 Ton
- PU4755-7523-A** kit33.95
- 1973 (2wd, Ser. 20, (4 dr)
- 1973 (2wd, Ser. 30)
- 1973-80 (2wd, 4wd, Ser. 10-30)
- 1974-78 (2wd, 4wd, Ser. 10-30, Blazer, Jimmy)
- P7380-7523-A** kit19.95

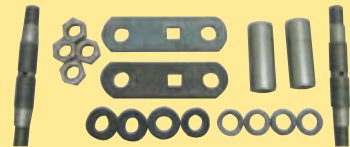

SPRING SHACKLE KIT

For front or rear springs.
1955-59 (1/2 & 3/4 Ton (Rear)

- 1955-59 Pickup (Front)
- PU5559-7523-A** kit29.95



REAR AXLE BUMPER

- 1973-76 (2WD, Ser. 10-20 (Cab, 2dr, Suburban)
- 1973-78 (2WD, Ser. 10-30, Blazer, Jimmy)
- P7378-7535-A** each13.95





FRAMES, SPRINGS, SHOCKS, BUMPERS

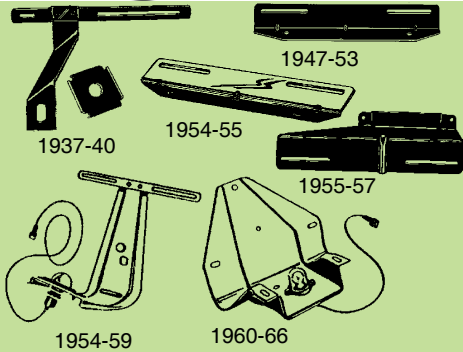

LICENSE PLATE BRACKET

- 1937-40 Pickup
Front license plate bracket, includes securing plate for installation.
P3740-7796-A each24.95
- 1941-46 Pickup
Front license plate bracket.
P4146-7796-A each24.95
- 1947-53 Pickup
Front license plate bracket in black, bolts to the gravel pan.
P4753-7796-A each11.95
- 1947-53 Pickup
Chrome plated front license bracket.
P4753-7796-CH each11.95
- 1954-55 Pickup
Front license plate bracket in black, bolts to gravel pan.
P54-7796-A each14.95
- 1954-55 (1st) Pickup
Chrome plated front license bracket.
P54-7796-CH each16.95
- 1954-59 Pickup
Rear license plate bracket, complete with lamp - black.
P5459-7796-RB each49.95
- 1955-57 Pickup
Front license plate bracket in black, bolts to gravel pan.
P5557-7796-A each9.95
- 1958-59 Chevy and GMC
Front license plate bracket in black.
P5859-7796-A each12.95
- 1960-66 Pickup
Rear license plate bracket, complete with lamp installed - black.
P6066-7796-RB each49.95

REAR LICENSE PLATE PANEL

- Die stamped steel as original.
1967-72 Pickup
P6772-7800-A each29.95

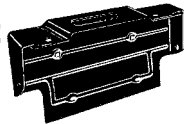

REAR FOLD UP LICENSE BRACKET

- For use with hide-away hitch.
1967-72 All with factory style bumper
P6772-7800-FLIP each44.95

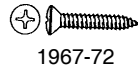

1967-72



1938-70

LICENSE PLATE MOUNTING BOLT

- Round stainless polished capped bolt w/lock nut.
1967-72 Pickup, bumper bolt w/ stainless cap (3/8" - 16 x 7/8")
P6772-7796-MBA each1.95
- 1938-70 All
(1/4" - 14 x 1)
P3870-7800-BLT each1.95

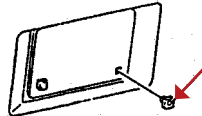

1978-84



1/4"-20 screw

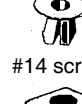

#14 screw



1/4" #14

LICENSE PLATE NUT

- (1/4"-20 screw size)
M-7800-MBA each95
- (#14 screw size)
M-7800-MBC each95
- (1/4" #14)
M-7800-MBD each95
- 1978-84 All
F6781-7800-N each1.95

CAMEO SPARE TIRE CARRIER

- Fiberglass. Super high quality!
1955-58 Pickup
P5558-7800-C each239.95

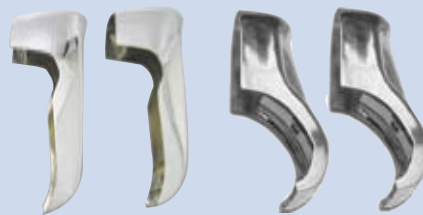

1967-72

1955-59

FRONT BUMPER GUARDS

- 1947-55 Chevy/GMC Pickup
Quality chrome heavy steel forging.
P4755-7828-A pair59.95
- 1955-59 Pickup
Chrome plated, complete w/hardware.
P5559-7828-AS pair169.95
- 1960-62 Pickup
P6062-7828-AS pair169.95
- 1963-66 Pickup
Fits original bumper only!!!
P6366-7828-AS pair169.95
- 1967-72 Pickup
P6772-7828-AS pair99.95
- 1973-80 Pickup (Chrome)
P7380-7828-PR pair89.95

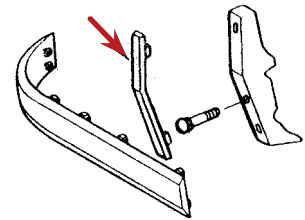

FRONT BUMPER GUARD STRIP

- Chrome, uses plastic push on attach.
1977-84 (2wd, 4wd, Ser. 10-30)
P7784-7828-A each19.95



BUMPER GUARD MOUNTING CLIP

- (3/4 x 5/8 hole)
1973-78 All
F7681-7829-A each1.95



1931-35



1936-40

1931-35 - center bolt

BUMPER BOLTS

- End bolts, polished stainless includes nuts & washers. Fits in end bumper.
1931-35 Pickup (end bolt)
P3135-7874-SSA each19.95
- 1931-35 Pickup (center bolt)
P3135-7874-SSB each21.95
- 1936-40 Pickup
P3640-7874-SSA each9.95

POLISHED STAINLESS STEEL BUMPER

- 1938-39 Pickup (Front or Rear)
P3839-7831-SSA each349.95
- 1940 Pickup (Front or Rear)
P40-7831-SSA each349.95
- 1941-46 Pickup (Front or Rear)
P4146-7831-SSA each349.95
- 1947-53 Pickup (Rear)
P4753-7831-SSA each349.95
- 1947-54 Pickup, Panel & Suburban (Front bumper)
1947-54 Panel or Suburban (Rear bumper)
P4754-7831-SSA each349.95





..... Chrome Plated Bumpers

CHROME FRONT BUMPER

		
1931-32 Pickup P3132-7831-CA each 349.95	1955-59 Pickup P5559-7831-CA each 169.95	1967-70 Pickup P6770-7831-CA each 119.95
1933 Pickup P33-7831-CA each 349.95		1969-72 GMC Pickup P6972-7831-GF each 159.95
1934-36 Pickup (front) Front bumper w/hump in center of bumper. P3436-7831-CA each 349.95	1960-62 Chevy/GMC Pickup P6062-7831-CA each 149.95	
1934-36 Pickup Front bumper w/o hump. P3436-7831-CB each 349.95		1971-72 Pickup P7172-7831-CA each 119.95
	1963-66 Chevy/GMC Pickup P6366-7831-CA each 149.95	1973-80 Chevy Pickup Without marker holes. P7380-7831-CA each 129.95

CHROME FRONT/REAR BUMPER

		
1937 Pickup (Front or Rear) Requires 5 bolts. P37-7831-CA each 349.95	1938-39 Pickup (Front or Rear) P3839-7831-CA each 349.95	1947-54 Pickup, Panel & Suburban (Front or Rear) P4754-7831-CA each 149.95
	1940 Pickup (Front or Rear) P40-7831-CA each 349.95	
	1941-46 Pickup (Front or Rear) P4146-7831-CA each 349.95	

CHROME REAR BUMPER

		FLEETSIDE = WIDE BED STEPSIDE = NARROW BED
1931-32 Pickup P3132-7831-CB each 349.95	1955-66 Pickup (Stepside, rear) P5566-7831-RCSB each 169.95	
1936 Pickup Requires 5 bolts. P37-7831-CA each 299.95		1967-72 Fleetside, Pickup, Blazer and Suburban P6772-7831-CB each 119.95
	1958-59 Chevy and GMC Fleetside (Chrome) P5859-7831-FRB each 249.95	
1947-53 Pickup P4753-7831-CA each 149.95		1967-72 Pickup (Stepside) P6772-7831-RB each 159.95
	1960-62 Chevy/GMC Fleetside (Chrome) Without license plate holes. P6062-7831-CB each 179.95	
1954 Early 1955 Stepside Pickup Triple plated, duplicate of original. P5455-7831-CA each 149.95		1973-80 Chevy/GMC P7380-7831-RC each 119.95
	1963-66 Chevy/GMC Fleetside (Chrome) P6366-7831-CB each 149.95	



FRAMES, SPRINGS, SHOCKS, BUMPERS



REAR GRAVEL SHIELD RUBBER SEAL

1947-59 Panel or Suburban
P4754-7833-A each14.95



METAL BUMPER DEFLECTOR/ GRAVEL SHIELD

1967-72 Fleetside Pickup & Blazer
 Left hand
P6772-7833-A each11.95
 1967-72 Fleetside, Blazer
 Right hand
P6772-7833-B each11.95



FIBERGLASS BUMPER DEFLECTOR

The filler pan between body & bumper on Panel & Suburbans. Includes 4 mounting brackets. Fiberglass.
 1947-55 (1st Ser) Panel & Suburban
P4754-7833-B each119.95



1960-66

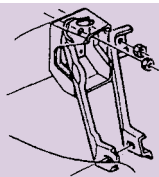

1967-70

FRONT BUMPER BRACKETS

1960-66 Chevy/GMC Pickup, Panel, & Suburban
 Left hand. Fits 1/2 ton thru 1 ton 2 wheel drive.
P6066-7836-LH each29.95
 1960-66 Chevy/GMC Pickup, Panel, & Sub.
 Right hand, fits 1/2 ton thru 1 ton 2 wheel drive.
P6066-7836-RH each29.95
 1967-70 Chevy/GMC (outer) Left hand
P6770-7836-LH each24.95
 1967-70 Chevy/GMC (outer) Right hand
P6770-7836-RH each24.95
 1971-72 Chevy/GMC (outer) Left hand
P7172-7836-LH each24.95
 1971-72 Chevy/GMC (outer) Right hand
P7172-7836-RH each24.95
 1973-80 Chevy/GMC (inner) Left hand
P7380-7836-LH each29.95
 1973-80 Chevy/GMC (inner) Right hand
P7380-7836-RH each29.95



1931-33

FRONT BUMPER BRACKET SET

One set does ONE bumper.
 1931-33 Pickup
P3133-7836-AS set169.95
 1934-36 Chevy/GMC
P3436-7836-AS set199.95
 1937 Chevy/GMC
P37-7836-AS set199.95
 1938-39 Pickup
 1938-39 1/2 and 3/4 Ton Pickup
P3839-7836-AS set199.95
 1940 Chevy/GMC
P40-7836-AS set149.95
 1941-46 Chevy/GMC
P4146-7836-AS set139.95
 1947-55 Chevy/GMC (1/2-3/4 Ton only)
 Includes mounting bolts.
P4755-7836-AS set139.95
 1955-57 Chevy/GMC
 Includes 2 inner & 2 outer brackets.
P5557-7836-FSET set89.95
 1958-59 Chevy/GMC
 Includes 2 inner & 2 outer brackets.
P5859-7836-FSET set89.95
 1967-70 Chevy GMC
 Left hand outer right hand outer; left hand inner
 right hand inner.
P6770-7836-FSET set79.95
 1971-72 Chevy and GMC
 Includes left hand outer right hand outer, left
 hand inner, right hand inner.
P7172-7836-FSET set79.95



BUMPER BRACE COVERS

Fits over front brace openings. Covers bumper brackets on rear bumpers. Sold in pairs. Fits Fleetside only.
 1960-66 Pickup (Fleetside)
P6066-7836-RC pair39.95

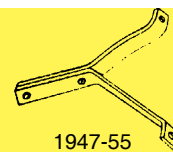

1947-55

REAR BUMPER BRACE/BACKET SET

One set does ONE bumper.
 1931-32 Pickup
P3136-7836-BS set199.95
 1937 Chevy/GMC
P37-7836-BS set199.95
 1938-39 Chevy/GMC
P3839-7836-BS set159.95
 1940 Chevy/GMC
P40-7836-BS set199.95
 1941-46 Chevy/GMC
P4146-7836-BS set139.95
 1947-55 Chevy/GMC
P4755-7836-BS set99.95
 1955-59 Chevy/GMC Stepside
P5566-7836-SBB set99.95
 1960-62 Chevy/GMC Stepside (w/ torsion susp.)
P6062-7836-AS set129.95
 1960-62 Chevy/GMC Fleetside
P6062-7836-BS set99.95
 1963-66 Chevy/GMC Stepside
P6366-7836-SS set89.95
 1963-66 Chevy/GMC Fleetside
P6366-7836-SET set49.95
 1967-72 Chevy/GMC All
P6772-7836-SET set59.95
 1973-80 Chevy Fleetside bumper
P7380-7836-RSET set149.95



FRONT BUMPER BOLT KIT

Stainless steel with polished hex and carriage head.
 1955-59 Pickup
P5559-7874-P kit29.95
 1960-66 Chevy/GMC Pickup
P6066-7874-P kit21.95
 1967-72 Pickup
P6772-7874-P kit24.95
 1973-80 Pickup
P7380-7874-P kit39.95



Gotta question?
 Ask Mike! He's here to help.

**We appreciate
 your business!**



Frames, Springs, Shocks and Bumpers continued....



STAINLESS STEEL BUMPER BOLT

Capped pan head, w/o nuts, (3/8" - 16 x 1")

M-7874-AS each95

Capped pan head, w/o nuts, (7/16"-14 x 1")

M-7874-BS each1.95

Capped pan head, (7/16"-14 x 1-3/8")

M-7874-CS each1.95

Uncapped round head, w/o nuts, (7/16"-14 x 1-1/4")

M-7874-DS each1.95

Uncapped round head, w/o nuts, (7/16"-14 x 1-1/2")

M-7874-ES each1.95

Capped pan head, w/o nuts, (m8-1.25 x 25 mm)

M-7874-FS each1.95

Capped pan head, w/o nuts, (m8-1.25 x 20mm)

M-7874-GS each1.95

1973-78 All, Blazer, Jimmy

Capped, high crown head, w/o nuts (1/2"-13 x 2)

M-7874-HS each1.95



REAR BUMPER BOLT KIT

Stainless steel w/ polished hex & carriage head.
1955-59 Pickup (Stepside)

P5559-7874-PS kit22.95

1960-66 Pickup (Stepside)

P6066-7874-PS kit19.95

1967-72 Pickup (Stepside)

P6772-7874-PS kit29.95



1/2 - 13 STAINLESS HEX NUTS

1960-80 All

P6078-7874-NT each95

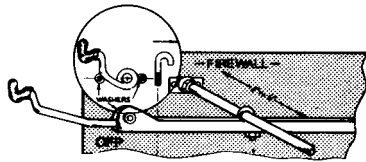

HOOD PROP KIT

This is an early accessory made to rest the hood on to save the paint, a must for the restorer.

1932-35 Chevy Pickup

B-8000-HP each29.95



HOOD CORNERS

1937-46 Pickup

P3746-8000-HC pair16.95

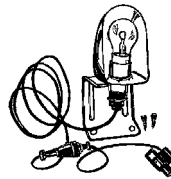

UNDERHOOD LAMP KIT

1947-85 Pickup

P4785-8000-LK each19.95



1955-59



1964-72



1973-85

FRONT CAB TO FLOOR SUPPORT

(2 1/2" x 14 1/2") O.E. Style. Fits between frame & rocker panel, die-stamped steel.

1947-55 Pickup (Left hand)

P4755-8000-FL each34.95

1947-55 Pickup (Right hand)

P4755-8000-FR each34.95

Die-stamped steel.

1955-59 Pickup (Left hand)

P5559-8000-FL each59.95

1955-59 Pickup (Right hand)

P5559-8000-FR each59.95

1964-72 Chevy GMC Pickup (Fits either side)

P6472-8000-FS each19.95

1973-85 Pickup, Suburban, Blazer, Jimmy
Left hand

P7385-8000-LCFS each19.95

1973-85 Pickup, Suburban, Blazer, Jimmy
Right hand

P7385-8000-RCFS each19.95



1955-59



1967-72



1973-90

REAR CAB TO FLOOR SUPPORT

Die-stamped steel.
1955-59 Pickup

P5559-8000-R each69.95

1967-72 Pickup, Panel, Suburban, Blazer, Jimmy
Left hand

P6072-8000-FSL each19.95

1967-72 Pickup, Panel, Suburban, Blazer, Jimmy
Right hand

P6072-8000-FSR each19.95

1973-90 Blazer (Left hand)

P7390-8000-RLH each34.95

1973-90 Blazer (Right hand)

P7390-8000-RRH each34.95



1955-56

NEW!

HOOD ASSEMBLY

Die stamped steel, exact duplicate of original.
1955-56 Chevy

P5556-8000-A each499.95



1967-68 Chevy/GMC Pickup, Blazer, and
Suburbans

P6768-8000-A each439.95



1969-72 Ser 10-30 (EXC. D-D)

P6972-8000-A each459.95

1973-80 Pickup/Suburban/Blazer

P7380-8000-A each169.95

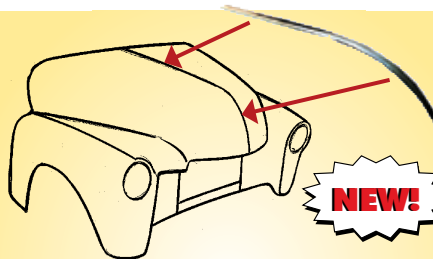

NEW!

PICK-UP HOOD CENTER DIVIDER STRIP

Complete with welded clips. Fits 1/2 ton thru 1 ton.

1947-55 1st Ser. Chevy Pickup (Plain steel)

P4753-8000-CNTR each79.95

1947-54 GMC only (Stainless steel)

P4754-8000-SSGMC each119.95

1947-55 Chevy (Stainless steel)

P4755-8000-SSHM each99.95



FRONT END SHEET METAL, HEATER PARTS



NEW!

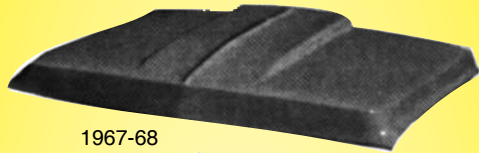

1967-68



1969-72



1973-80



1988-99



1994-02

STAMPED STEEL COWL INDUCTION HOOD ASSEMBLY

Die stamped steel reproduction. **Truckline only**

1967-68 Chevy/GMC All

P6768-8000-I each469.95

1969-72 Chevy

P6972-8000-CI each449.95

1973-80 Pickup

P7380-8000-I each499.95

1981-91 Chevy PU

P8187-8000-I each499.95

1982-93 S-10 Pickup

1983-94 Blazer/Jimmy/Olds Bravada

P8293-8000-I each349.95

1988-99 Chevy/GMC Pickup

1992-99 Blazer and Suburban

2" cowl, uses original hinges & latch. 2 3/4" carburetor clearance, raised center spine.

P8899-8000-I each499.95

1994-02 S10 Pickup

1995-02 Blazer/Jimmy/Olds Bravada

P94U-8000-I each349.95

1994-02 S-10 Pickup

1995-02 Blazer/Jimmy/Olds Bravada

With 2nd design.

P94U-8000-I2 each349.95

1999-02 Pickup/Tahoe/Suburban

P99U-8000-I each449.95



STEEL RAM AIR STYLE HOOD

Die stamped steel.
1988-98 Chevy, GMC Pickup

P8898-8000-RA each499.95



BODY BOLT W/WASHER

(5/16" - 18 x 7/8") Black phosphate with 3/4" od. 1/2" hex head.

1967-72 Pickup

P6772-8000-MB set of 10.2.95

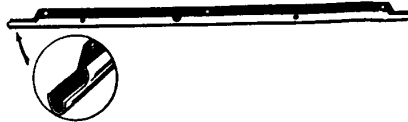

WIRE HARNESS GUTTERS

(Under hood) includes front & rear.

1967-72 Pickup

P6772-8000-PR pair19.95

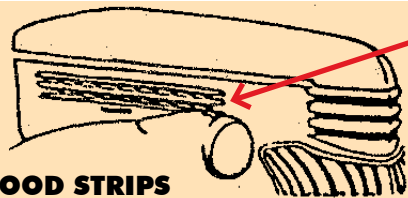

HOOD STRIPS

Stainless steel with red centers. Horizontal strips on hoodsides.

1941-46 Pickup

P4146-8001-AS set.119.95



HOOD BRACE PAD SET

8 pc. sponge set.

1960-66 Pickup

P6066-8009-HBP set12.95

1967-72 Pickup

P6772-8009-AS set.12.95



HOOD PANEL FILLER NUT

J-shaped, requires 14.

1960-61 Ser 10-30

P6061-8010-NUT each6.95



COWL HOOD LEDGE SEAL

1973-80 (2wd, 4wd, Ser. 10-30)

P7380-8010-A each26.95



HOOD HINGE BOLT KIT

Hex head bolt kit (does both hinges).

Late 1947 thru Early 1955

P4755-1003-H kit6.95



HOOD HINGE SPRING

1955-57 Pickup

P5557-8013-A each11.95

1958-59 Pickup

P5859-8013-A pair19.95

1960-66 Chevy/GMC Pickup

P6066-8013-A each9.95

1967-72 Ser 10-30 & Blazer (exc. D-D)

P6772-8013-A each14.95

1973-80 (2wd, 4wd, Ser. 10-30, Blazer, Jimmy)

P7380-8013-A each22.95



HOOD LATCH, CATCH AND BRACKET BOLT KIT

Stainless steel hex & phillips head.

Late 1947 - Early 1955 Pickup

P4755-8015-HP kit8.95

**We accept
Visa,
Master
Card, and
Discover.**

FRONT END SHEET METAL, HEATER PARTS



HOOD HINGE ASSEMBLY

- 1934-40 Chevy-GMC (chrome)
P3440-8015-A each **139.95**
 1941-46 Chevy-GMC (chrome)
P4146-8015-A each **139.95**
 Set - Complete with upper and lower hinges.
 1947-55 1st Chevy GMC Pickup
 (For l/h side.)
P4755-8015-LH set. **49.95**
 1947-55 1st Chevy or GMC Pickup
 (For r/h side.)
P4755-8015-RH set **49.95**
 1955-57 Chevy & GMC (Left hand)
P5557-8015-LH each **64.95**
 1955-57 2nd Series Chevy & GMC (Right hand)
P5557-8015-RH each **64.95**
 1958-59 Chevy & GMC (Left hand)
P5859-8015-LH each **64.95**
 1958-59 Chevy & GMC (Right hand)
P5859-8015-RH each **64.95**
 1960-66 Chevy/GMC Pickup (Left hand)
P6066-8015-LH each **59.95**
 1960-66 Chevy/GMC Pickup (Right hand)
P6066-8015-RH each **59.95**
 1967-72 Ser 10-30 & Blazer (exc. D-D) (Left hand)
P6772-8015-A each **59.95**
 1967-72 Ser 10-30 & Blazer (exc. D-D) (Right hand)
P6772-8015-B each **59.95**
 1973-80 2wd, 4wd, Ser. 10-30, Blazer, Jimmy
 (Left hand)
P7380-8015-LH each **89.95**
 1973-80 2wd, 4wd, Ser. 10-30, Blazer, Jimmy
 (Right hand)
P7380-8015-RH each **89.95**



HOOD BRACE BOLT KIT

- Stainless steel indented hex flanged head
 (original).
 1955-59 Pickup
P5559-8015-IF kit **3.95**
 1960-66 Pickup
P6066-8015-IF kit **6.95**



HOOD LATCH BOLT KIT

- Stainless steel indented hex head.
 1960-66 Pickup
P6066-8015-I kit **5.95**
 1967-72 Pickup
P6772-8015-I kit **7.95**

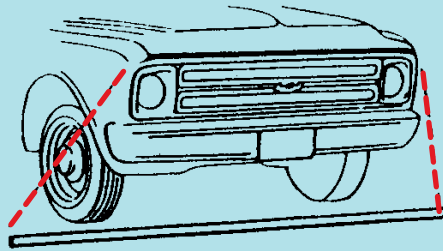

HOOD FRONT MOULDING UNIT

- Anodized aluminum, with mounting clips.
 1968 Ser 10-30 (Exc. D-D)
P68-8015-A each **69.95**



HOOD HINGE SHOULDER BOLT KIT

- 1947-55 (1st Series) Pickup
P4755-8016-S set of 6 **9.95**



FRONT HOOD ADJUSTMENT ROUND RUBBER BUMPER

- Fits over adjustment screw.
 1955-66 Chevy/GMC Pickup
A6472-8024-HBR pair **1.95**

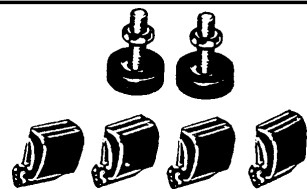

HOOD BUMPER SET

- 1937-46 Pickup
P3746-8024-AS set. **4.95**
 1947-55 Pickup
P4754-8024-AS kit **7.95**
 1955-59 Pickup
P5559-8024-AS set. **7.95**
 1960-61 Pickup
P6061-8024-AS kit **8.95**
 1962-66 Pickup
P6266-8024-AS kit **8.95**



HOOD SIDE & FRONT FENDER BUMPER SET

- 1967-72 Pickup
P6772-8024-AS set of 6 **8.95**



HOOD SIDE BUMPER SET

- 1967-72 Pickup
P6772-8024-HSBK set **3.95**



HOOD ADJUSTERS WITH RUBBER BUMPERS

- 1967-72 Pickup
P6772-8024-SB pair **3.95**



RUBBER BUMPER

- 1971 Ser 10-30 & Blazer - glove box door bumper
 1960-65 Ser 10-30 (single unit) - front license plate bumper
 1947-55 Comm, hood panel to fender bumper
 1955-59 Ser 3, hood panel to radiator grill bumper & hood panel to cowl
 1961-62 All
 1975-76 (2wd, 4wd, Ser. 10-30, Blazer, Jimmy - front fender skirt bumper)
 1973-78 (2wd, 4wd, Ser. 10-30, Blazer, Jimmy - door window glass stop bumper)
 1973-78 (2wd, 4wd, Ser. 10-30, Blazer, Jimmy - door lock remote control handle)
 1979-84 (2wd, 4wd, Ser. 10-30 - side door window glass stop bumper)
 1979-80 (2wd, 4wd, Ser. 10-30 - side front & rear door lock remote control)
P71-8024-BM each **2.95**



HOOD PANEL FRONT BUMPER

- Requires 2.
 1960-61 Ser 10-30
P6061-8024-A each **2.95**



GMC ACCESSORY HOOD ORNAMENT

- Two piece design as original, chrome plated.
 1947-55 GMC Pickup.
P4755-8055-GMC each **374.95**



HOOD BIRD ORNAMENT

- Exact reproduction of the original truck optional hood bird ornament, chrome plated.
 1953-54 Chevy PU
P5354-8055-HB each **299.95**



FRONT END SHEET METAL, HEATER PARTS

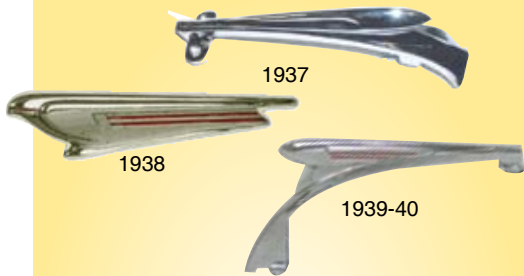

CHROME HOOD ORNAMENT

Made of quality show chrome in the U.S.A.

1937 Chevy Pickup

P37-8055-A each217.95

1938 Chevy Pickup

Coming soon
P38-8055-A each259.95

1939-40 Chevy Pickup

Special for these two years only!

P3940-8055-A each217.95

1977-78 (2wd, 4wd, Ser. 10-30, Blazer)

1978 Chevy Pickup

1979 (2wd, 4wd, Ser. 10-30, Chevy, exc Z77)

1980 (2wd, 4wd, Ser. 20,

1980 (2wd, 4wd, Ser. 30, (2 door cab w/ 8 ft bed Stepside or Fleetside)

P7880-8055-A each82.95

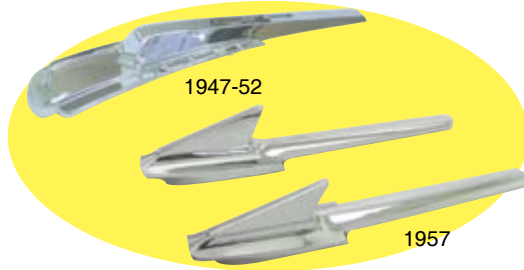

ACCESSORY HOOD ORNAMENT

These were an original accessory option.

Chrome plated.

1947-52 Pickup

P4753-8055-ACC each139.95

1957 Pickup

Hood rockets.

P57-8055-ACC pair299.95



FRONT HOOD EMBLEM

'Bowtie Chevrolet' hood emblem. An excellent reproduction of the original with Chevrolet insignia and details. Painted the correct red & blue colors, chrome plated.

1947-53 Pickup

P4753-8055-A each69.95



HOOD EMBLEM MOUNTING GASKET

1947-53 Pickup

P4753-8055-MG each4.95

1954 Pickup

P54-8055-MG each4.95



HOOD EMBLEM DECAL SET

Red & blue as original.

1947-53 Pickup

P4753-8055-DC set9.95



HOOD EMBLEM & GRILL DECAL

White background with black letters.

1954-55 Pickup

P5455-8055-BLK set8.95

Red back ground with black letters.

1954-55 Chevrolet Pickup

P5455-8055-RB each8.95

Red back ground with white letters.

1954-55 Chevrolet Pickup

P5455-8055-RW each8.95

White background with white letters.

1954-55 Chevy Pickup

P5455-8055-WH set8.95

CHEVROLET

1967-68

G M C

1968-72

CHROME HOOD LETTER SET

"Chevrolet"

1967-68 Pickup

P6768-8055-HLS set39.95

"GMC"

1968-72 GMC Pickup

P6872-8055-GMC set59.95



BOWTIE GRILL EMBLEM

Chrome with red details, chrome plated.

1967-68 Pickup

P6768-8055-RBT each49.95



BOWTIE HOOD EMBLEM

With fasteners, chrome plated.

1969-70 Chevy Pickup

P6970-8055-BT each49.95



NEW!

HOOD LATCH PANEL

Complete with latch and handle, chrome plated.

1947-53 Chevy Pickups

P4753-8080-SS each239.95

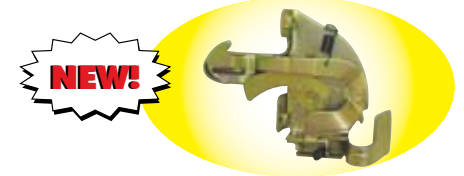

HOOD LATCH ASSEMBLY

1955-57 Pickup, Panel, & Suburban

P5557-8080-A each79.95

1958-59 Chevy/GMC Pickup

P5859-8080-A each77.95



CHEVY/ GMC HOOD LATCH

1967-68 Chevy/GMC

P6768-8080-HL each59.95

1969-70 Chevy/GMC

P6970-8080-HL each59.95

1971-72 Chevy/GMC

P7172-8080-HL each59.95

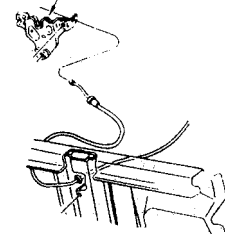

UPPER HOOD LATCH ASSEMBLY

1977-80 (2wd, 4wd, Ser. 10-30, Blazer, Jimmy (w/ inside hood release)

P7780-8083-A each59.95



Front Fenders

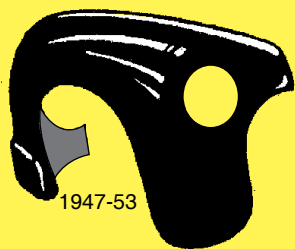

1947-53



1958-59



NEW!



1957

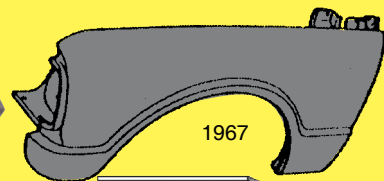

1967



1969-72



1931-32



Special Order

FIBERGLASS FRONT FENDER

All fiberglass fenders are made to order. Fenders must be paid for in advance before ordering. Allow 4-6 weeks delivery. Special orders are non-returnable.

- Left hand
- 1931-32 Pickup 1/2 ton to 1 1/2 ton
- P3132-8130-FGL each399.95**
- 1931-32 (1/2 ton- 1-1/2 ton)
- Right hand
- P3132-8130-FGR each399.95**
- 1933 Pickup
- Left hand
- P33-8130-FGL each399.95**
- 1933 Pickup
- Right hand
- P33-8130-FGR each399.95**
- 1934-35 Pickup
- Left hand
- P3435-8130-FGL each399.95**
- 1934-35 Pickup
- Right hand
- P3435-8130-FGR each399.95**
- 1936 Pickup
- Left hand
- P36-8130-FGL each399.95**
- 1936 Pickup
- Right hand
- P36-8130-FGR each399.95**
- 1937-38 Pickup
- Left hand
- P3738-8130-FGL each399.95**
- 1937-38 Pickup
- Right hand
- P3738-8130-FGR each399.95**
- 1939-40 Pickup
- Left hand
- P3940-8130-FGL each399.95**
- 1939-40 Pickup
- Right hand
- P3940-8130-FGR each399.95**
- 1941-46 Pickup
- Left hand
- P4146-8130-FGL each399.95**
- 1941-46 Pickup
- Right hand
- P4146-8130-FGR each399.95**



NEW!

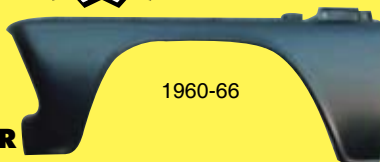

1960-66

FRONT FENDER

Die stamped steel. Exact duplicate of originals.

- 1947-53 Chevy Pickup
- Left hand
- P4753-8130-LH each389.95**
- 1947-53 Chevy Pickup
- Right hand
- P4753-8130-RH each389.95**
- 1954-55 1st Series Chevy Pickup, Panel, & Suburban
- Left hand
- P5455-8130-LH each389.95**
- 1954-55 1st Series Pickup, Panel, & Suburban
- Right hand
- P5455-8130-RH each389.95**
- 1955-56 Chevy Pickup
- Left hand
- P5556-8130-LH each389.95**
- 1955-56 Chevy Pickup, Panel, & Suburban
- Right hand
- P5556-8130-RH each389.95**
- 1957 Chevy Pickup
- Left hand
- P57-8130-LH each389.95**
- 1957 Chevy Pickup
- Right hand
- P57-8130-RH each389.95**
- 1958-59 (1/2 & 3/4 Ton Pickup, Panel, & Suburban)
- Left hand
- P5859-8130-LH each389.95**
- 1958-59 All 1/2 - 3/4 Ton Pickup, Panel, Suburban
- Right hand
- P5859-8130-RH each389.95**
- 1960-66 Chevy
- Left hand
- P6066-8130-LH each249.95**
- 1960-66 Chevy
- Right hand
- P6066-8130-RH each249.95**



NEW!



NEW!

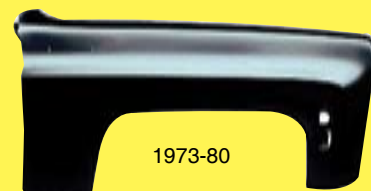

1973-80

- 1967 Pickup, GMC, Suburban
- Left hand (no marker light hole) **Truck freight only**
- P67-8130-LH each179.95**
- 1967 Pickup, GMC, Suburban
- Right hand (no marker light hole) **Truck freight only**
- P67-8130-RH each179.95**
- 1968 Chevy
- 1968-72 GMC
- Left hand ***Truck freight only***
- P6872-8130-LH each179.95**
- 1968 Chevy
- 1968-72 GMC
- Right hand ***Not UPS able***
- P6872-8130-RH each179.95**
- 1969-72 Ser 10-30 & Blazer (exc. D-D)
- Left hand **Truck freight only**
- P6972-8130-AL each149.95**
- 1969-72 Ser 10-30 (exc. D-D) **Will fit Chevy only**
- Right hand
- P6972-8130-AR each149.95**
- 1973-80 (2wd, 4wd, Ser. 10-30, Blazer, Jimmy)
- Left hand *** not UPS able***
- P7380-8130-LH each99.95**
- 1973-80 (2wd, 4wd, Ser. 10-30, Blazer, Jimmy)
- Right hand ***Not UPS able***
- P7380-8130-RH each99.95**
- 1981-87 Chevy Pickup
- Left hand side
- P8187-8130-LH each99.95**
- 1981-87 Chevy Pickup
- Right hand side
- P8187-8130-RH each99.95**





FRONT END SHEET METAL, HEATER PARTS

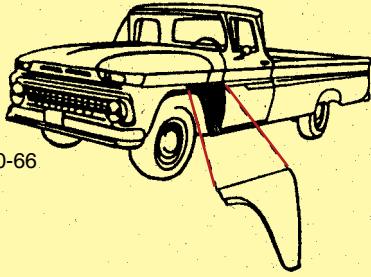

1960-66

FRONT FENDER PATCH, REAR SECTION

- Die-stamped steel.
1955-57 Pickup & Panel
Lower rear, left hand
P5557-8130-LRFF each99.95
1955-57 Pickup & Panel
Lower rear, right hand
P5557-8130-RRFF each99.95
1960-66 Pickup (up to 1 ton) & Panel
Lower, right hand
P6066-8130-RRFF each69.95
1960-66 Pickup (up to 1 ton) Panel
Lower rear, left hand
P6066-8130-LRFF each69.95
1967-72 (Up to 1 ton) Pickup, Suburban, Blazer, Jimmy
Lower rear, left hand
P6772-8130-LRFF each69.95
1967-72 (up to 1 ton) Pickup, Suburban, Blazer, Jimmy
Lower rear, right hand
P6772-8130-RRFF each69.95

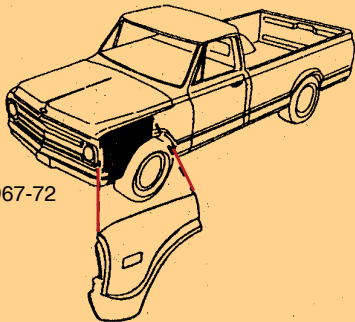

1967-72

FRONT FENDER PATCH, FRONT SECTION

- Die-stamped steel.
1960-66 Pickup (up to 1 ton), Panel
Lower, left hand
P6066-8130-LLFF each79.95
1960-66 Pickup (up to 1 ton) Panel
Lower, right hand
P6066-8130-RLFF each79.95
1967-72 Pickup (up to 1 ton) Panel & Blazer
Lower left hand
P6772-8130-LLFF each79.95
1967-72 Pickup (up to 1 ton) Panel & Blazer
Lower, right hand
P6772-8130-RLFF each79.95

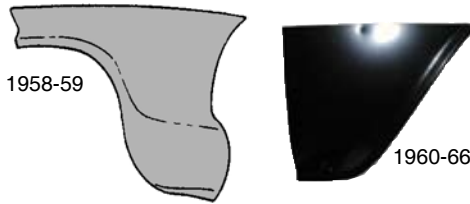

REAR LOWER FRONT FENDER PATCH PANEL

- Die-stamped steel.
1955-57 Chevy / GMC (Left hand)
P5557-8130-PL each49.95
1955-57 Chevy / GMC (Right hand)
P5557-8130-PR each49.95
1958-59 Chevy / GMC (Lower rear, left hand)
P5859-8130-LRFF each39.95
1958-59 Chevy / GMC (Lower rear, right hand)
P5859-8130-RRFF each39.95
1960-66 Chevy & GMC (Lower rear, left hand)
P6066-8130-PL each19.95
1960-66 Chevy & GMC Pickup (Rear, right hand)
P6066-8130-RP each19.95



FRONT INNER FENDER BOLT KIT

- Stainless steel indented hex head.
Late 1947 - Early 1955
P4755-8130-H kit19.95
1955-67 Pickup
P5566-8130-I kit28.95
1958-59 Pickup
P5859-8130-I kit19.95
1967-72 Pickup
P6772-8130-I kit28.95
1973-80 Pickup
P7380-8130-I kit32.95

BATTERY RUST REPAIR PANEL

- Right hand lower fender section.
Repairs battery leakage rust. Die-stamped steel.
1967-72 Pickup, Blazer, Suburban
P6772-8130-BR each52.95



Show off your truck!



CHEVY FRONT END BOLT KIT

- Kit includes all hardware for inner fender skirt, cowl panel, hood hinges, hood latch, latch plate, latch support, radiator support, and battery clamp. Kit also includes fender shins and headlamp bezel screws & grommets.
1967-72 Chevy
P6772-8130-FK kit39.95
1973-80 Truck
P7380-8130-FK kit39.95

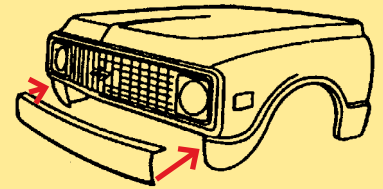

FRONT ROLL PAN

- Made of 18 gage steel. This takes the place of the front bumper for a slick smooth look.
1967-72 Chevy/GMC
P6772-8132-FRP each219.95



UPPER FENDER MOULDING FRONT BOLT ON CLIP

- Requires two per truck.
1969-72 Pickup, Blazer
P6972-8132-EC each1.95



FRONT FENDER EYEBROW MOLDING FOR GMC

- Extends from upper grill molding. Chrome plated.
1969-72 GMC All
Left hand
P6972-8132-GL each59.95
1969-72 GMC All
Right hand
P6972-8132-GR each59.95

FRONT END SHEET METAL, HEATER PARTS



LOWER FENDER MOLDING CLIP KIT

Fits either side. Push-in & screw type clips.

Requires 2.

1969-72 Pickup

Lower front.

P6972-8132-LFFC each 3.95

1969-72 Pickup

Lower rear

P6972-8132-LRFC each 5.95



UPPER FRONT FENDER MOLDING CLIP KIT

Fits either side. **Requires 2.**

1969-72 Pickup

P6972-8132-UMK kit 4.95



LOWER DOOR MOLDING CLIP KIT

Fits either side. **Requires 2.**

1969-72 Pickup

Push-in & screw type clips.

P6972-8133-A kit 15.95

1971-72 Pickup

Adhesive clips.

P7172-8133-B kit 15.95



CHROME CLUTCH HEAD FENDER BOLT

1955-59 Pickup

P5559-8143-A each 1.95

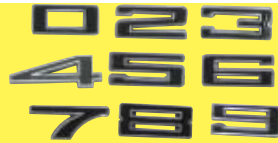

SELF-ADHESIVE INDIVIDUAL NUMERAL

Numeral 0

B-8147-0 each 19.95

Numeral 2

B-8147-2 each 19.95

Numeral 3

B-8147-3 each 19.95

Numeral 4

B-8147-4 each 19.95

Numeral 5

B-8147-5 each 19.95

Numeral 6

B-8147-6 each 19.95

Numeral 7

B-8147-7 each 19.95

Numeral 8

B-8147-8 each 19.95

Numeral 9

B-8147-9 each 19.95



HOOD SIDE EMBLEM

1947-49 Pickup

'Chevrolet Thriftmaster' with clips, chrome

P4749-8147-AS each 18.95

1947-52 Pickup

'3100', chrome

P4951-8147-A each 19.95

1947-52 Pickup

'Chevrolet 3100' with fasteners, chrome

P4951-8147-B pair 35.95

1953-54 Pickup

'3100' with clips, chrome

P5354-8147-A each 29.95

1955 Pickup (1st series)

'3100', chrome

P55-8147-A pair 109.95

1955 2nd Ser Pickups

"Chevrolet 3100", chrome

P55-8147-B pair 279.95

1961 Pickup

'Apache 10' with fasteners, chrome

P61-8147-A pair 59.95



'V8' FRONT FENDER EMBLEM

Chrome plated.

1955-56 Pickup

'V8'

P5556-8147-A pair 49.95



'V8' DOOR EMBLEM

Chrome plated.

1957 Pickup

P57-8147-A pair 49.95



'HYDRAMATIC' SCRIPT DOOR EMBLEMS

Chrome plated.

1957 Pickup

P57-8147-B pair 39.95



CUSTOM 10 & 20 FRONT FENDER EMBLEMS

With fasteners. Chrome plated.

1969-70 Pickup

'Custom 10'

P6970-8147-AS pair 44.95

1969-70 Pickup

'Custom 10'

P6970-8147-BS pair 39.95

1969-72 Pickup

'Custom 10'

P6972-8147-CAS pair 59.95

1969-72 Pickup

'Custom 20'

P6972-8147-CBS pair 59.95

**Why wait?
Don't punish
your truck any
longer.
Get it now!**



FRONT END SHEET METAL, HEATER PARTS

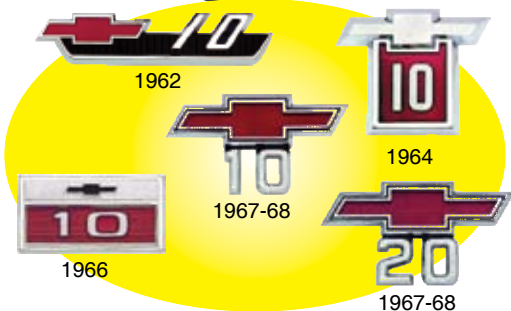

'BOWTIE' FRONT FENDER EMBLEMS

With fasteners. Chrome plated.

- 1962 Pickup
'Bowtie 10'
P62-8147-A pair59.95
- 1963 Pickup
'Bowtie 10'
P63-8147-AS pair59.95
- 1964 Pickup
'Bowtie 10'
P64-8147-AS pair59.95
- 1965 Pickup
'Bowtie 10'
P65-8147-AS pair59.95
- 1966 Pickup
'Bowtie 10'
P66-8147-AS pair59.95
- 1967-68 Chevrolet Pickup
'Bowtie 10'
P6768-8147-AS pair59.95
- 1969 Van
'Bowtie 20'
P6768-8147-BS pair89.95



P6972-8147-AS



P6972-8147-BS



P6972-8147-CS



P6972-8147-DS

ENGINE SIZE FRONT FENDER EMBLEM

With fasteners. Chrome plated.

- 1969-72 Pickup
'8-400'
P6972-8147-AS pair44.95
- 1969-72 Pickup
'8-396'
P6972-8147-BS pair39.95
- 1969-72 Pickup
'8-350'
P6972-8147-CS pair39.95
- 1969-72 Pickup
'8-454'
P6972-8147-DS pair39.95



GREAT QUALITY!

'3100' FENDER EMBLEMS

'Chevrolet 3100' Chrome plated with red painted details. Great quality!
1957 Pickup

P57-8147-C pair299.95



GREAT QUALITY!

'3124' FENDER EMBLEM

'Chevrolet 3124' Chrome plated with red painted inserts. Great quality!
1957 Pickup

P57-8147-D pair299.95



'CHEVROLET APACHE 10' FRONT FENDER EMBLEMS

'Chevrolet Apache 10' With fasteners. Chrome plated.
1960 Pickup

P60-8147-A pair69.95

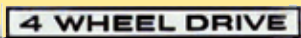
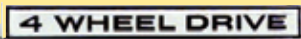

'4 WHEEL DRIVE' FRONT FENDER EMBLEMS

'4 wheel drive' With fasteners. Chrome plated.
1968-72 Pickup, Blazer, Suburban

P6872-8147-GBS pair49.95



FRONT FENDER EMBLEM

'K5 Blazer' Requires 2. Chrome plated.
1969-72 Blazer

P6972-8147-A each39.95



1967-81

1932-87

502 FRONT FENDER EMBLEM

1967-81 Chevy/GMC
A7072-8147-502 each23.95
1932-87 Chevy/GMC
Designed like the original 454 emblems on
1970-74.

A7074-8147-502 each23.95

**We appreciate
your business!**



P7172-8147-A



P7376-8147-AS



P7172-8147-DS

'CHEYENNE 10, 20 & 30' FRONT FENDER EMBLEMS

With clips. Chrome plated.

1971-72 Ser. 10 (w/ custom sport package)

'Cheyenne 10'
P7172-8147-A pair49.95

1973-76 Pickup
'Cheyenne Super 10'
P7376-8147-AS pair59.95

1971-72 Pickup
'Cheyenne 20'
P7172-8147-CS pair49.95

1971-72 Pickup
'Cheyenne 30'
P7172-8147-DS pair49.95



'DELUXE' FRONT FENDER EMBLEMS

Chrome plated.

1971-72 Pickup

P7172-8147-AS pair39.95



'SUPER' FRONT FENDER EMBLEM

Chrome plated w/ red painted inserts.

1971-72 Pickup

P7172-8147-BS pair39.95

**Can't find it?
Call us -
we'll get it
for you!**

FRONT END SHEET METAL, HEATER PARTS



'GMC 1500' FRONT FENDER EMBLEMS

Chrome plated w/ red painted inserts.
1968-72 GMC Pickup
'1500 V8'

P6872-8147-GAS pair79.95

1971-72 GMC Pickup, Suburban
'GMC 1500 Custom'

P7172-8147-GAS pair79.95

1971-72 GMC - Pickup, Suburban
'GMC 1500 Super Custom'

P7172-8147-GBS pair79.95

1971-72 Pickup
'GMC 1500 Sierra'

P7172-8147-GCS pair79.95

1971-72 GMC Pickup
'GMC 1500 Sierra Grande'

P7172-8147-GDS pair79.95



MISC. GMC FENDER SIDE EMBLEMS

Chrome plated w/ painted inserts.
1971-72 GMC (C2500)
'GMC 2500 V8'

P7172-8147-GES pair79.95

1971-72 GMC (C2500)
'GMC 2500 Custom'

P7172-8147-GFS pair79.95

1971-72 GMC (C2500)
'GMC 2500 Super Custom'

P7172-8147-GGS pair79.95

1971-72 GMC (C2500)
'GMC 2500 Sierra'

P7172-8147-GHS pair79.95

1971-72 GMC (C2500)
'GMC 2500 Sierra Grande'

P7172-8147-GIS pair79.95

1971-72 GMC (Jimmy)
'GMC Jimmy'

P7172-8147-GJS pair79.95



CUSTOM DELUXE - 10 EMBLEM

'Custom deluxe - 10' front fender emblem
1975-80 (2wd, 4wd, Ser. 10)

P7580-8147-A each44.95



CHEYENNE 10 EMBLEM

'Cheyenne 10' front fender emblem
1975-80 (2wd, 4wd, Ser. 10, Cheyenne)

P7580-8147-C each44.95



'SCOTTSDALE' FRONT FENDER EMBLEM

1975-80 (2wd, 4wd, Ser. 10, Scottsdale)
'Scottsdale 10'

P7580-8147-E each44.95

1975-80 (2wd, 4wd, Ser. 20, Scottsdale)
'Scottsdale 20'

P7580-8147-F each44.95



SILVERADO FRONT FENDER EMBLEM

1975-80 (2wd, 4wd, Ser. 10)
'Silverado 10'

P7580-8147-H each44.95

1975-80 (2wd, 4wd, Ser. 20)
'Silverado 20'

P7580-8147-I each44.95

1975-80 (2wd, 4wd, Ser. 30)
'Silverado 30'

P7580-8147-J each44.95



INNER FRONT FENDER

Black primed. Die stamped steel.
1947-53 Chevy Pickup, Panel, and Suburban
Left hand

P4753-8153-LA each159.95

1947-53 Chevy Pickup, Panel, and Suburban
Right hand

P4753-8153-RA each159.95



INNER FRONT FENDER PANEL

Die stamped steel.
1958-59 Chevy/GMC Pickup
Left hand

P5859-8153-LA each169.95

1958-59 Chevy/GMC Pickup
Right hand

P5859-8153-RA each169.95



LOWER INNER FENDER ANTI-SQUEAK GROMMETS

1955-59 Pickup

P5559-8153-S set of 45.95

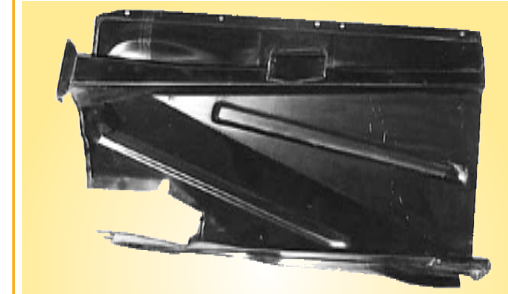

FRONT INNER FENDER

Die stamped steel.
1960-66 Pickup
Left hand

P6066-8153-LA each149.95

1960-66 Pickup
Right hand

P6066-8153-RA each149.95



FRONT END SHEET METAL, HEATER PARTS

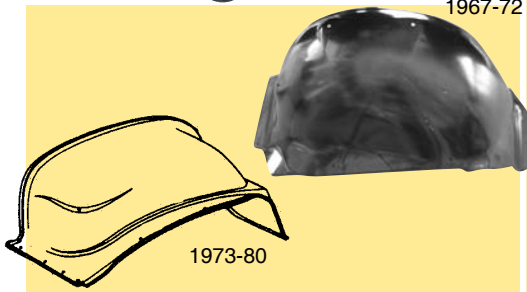

FRONT FENDER SKIRT

Die stamped steel.

1967-72 Ser 10-30 & Blazer (exc. D-D)

Left hand

P6772-8153-LA each69.95

1967-72 Ser 10-30 & Blazer (exc. D-D)

Right hand

P6772-8153-RA each69.95

1973-80 (2wd, 4wd, Ser. 10-30, Blazer, Jimmy)

Left hand

P7380-8153-LH each59.95

1973-80 (2wd, 4wd, Ser. 10-30, Blazer, Jimmy)

Right hand

P7380-8153-RH each59.95

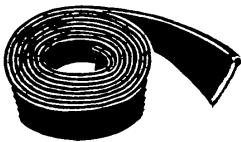

BLACK FENDER WELTING

30 ft. roll. This is enough to do all 4-fenders.

1932-72

(1/4" Bead)

B-8154-14B roll14.95

All

(5/32" bead)

B-8154-532B roll14.95



CHROME FENDER WELTING

30 ft. roll - This is enough to do all 4 fenders.

1/4" bead

B-8154-14C roll29.95

5/32" bead

B-8154-532C roll29.95

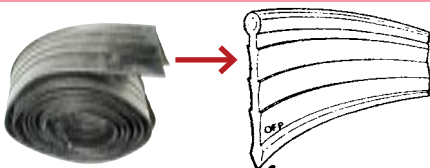

RUBBER FENDER WELTING WITH LOCK EDGES

(5/16" bead) 7ft. roll

Pickup

B-8154-RA each9.95

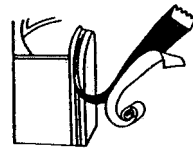

HOT ROD LACING

Rubber, with pressure sensitive adhesive backing. Just peel off and stick. (5/8" x 3/8")

All

HR-8154-CL roll11.95

(5/8" x 7/16")

All

HR-8154-RS roll9.95



HOOD TO COWL SEAL

Woven fabric as original.

1934-36 Pickup

P3436-8154-AS kit17.95

1937-41 Pickup

P3741-8154-AS set.12.95

Rubber

1942-46 Pickup

P4246-8154-AS set.14.95

Rubber, with retaining clips (under rear of hood).

1947-55 Pickup

P4754-8154-HLR each8.95

1955-59 Chevy Pickup

P5559-8154-HLR each9.95

1960-66 Chevy/GMC Pickup

P6066-8154-HLR each9.95

1967-72 Chevy/GMC Pickup

P6772-8154-HLR each9.95

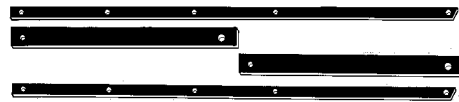

FRONT FENDER TO INNER FENDER GASKET SET

1941-46 Pickup

P4146-8154-IFGS set of 89.95

1947-54 Pickup

P4754-8154-IFG set of 814.95

INNER FENDER LOWER REAR MOUNT PAD SET

1941-46 Pickup

P4146-8154-RMP set6.95

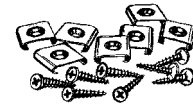

HOOD LACE RETAINER CLIP & SCREW KIT

1947-54 Pickup

P4754-8154-RSS kit5.95



FRONT INNER FENDER TO CAB SEALS

Goes between rear of fender and cab. Includes installation staples.

1955-59 Pickup

P5559-8154-DS pair4.95

1960-63 Pickup

P6063-8154-BS pair6.95

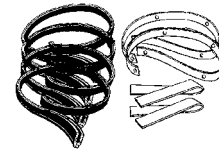

FRONT FENDER MOUNTING GASKETS

1955-59 Pickup

P5559-8154-FMG set of 814.95



INNER FENDER TO FIREWALL RUBBER SEALS

1955-59 Chevy/GMC

P5559-8154-FW pair8.95



FENDER TO HINGE PILLAR SEAL

With staples.

1960-63 Chevy GMC Pickup

P6063-8154-HPS each14.95

1964-66 Chevy

P6466-8154-HPS each14.95



FRONT LOWER SPLASH PAN SEAL

1960-66 Pickup

P6066-8154-BS each3.95

FRONT END SHEET METAL, HEATER PARTS



HOOD TO RADIATOR SEAL KIT

1960-66 Pickup
P6066-8154-HRS set 4.95



COWL SEAL

Under cowl upper grille.
 1967-72 Pickup
P6772-8154-AS pair 1.95



FRONT INNER FENDER DUST SEAL SET

Includes installation staples. (6 pc. kit)
 1967-72 Pickup
 Goes between rear of fender and cab.
P6772-8154-DS set. 29.95



1967-72 Pickup
 Front fender inner shield.
P6772-8154-SHK kit. 14.95



DUST SHIELD & COWL RETAINER

1973-78 Ser. 10-30, Blazer, Jimmy (Arm rest retainer)
 1979-84 2wd 4wd Ser 10-30 (Door panel hole retainer)
F6781-8154-A each 1.95

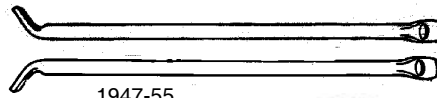

1947-55



1955-59



1955-59 lower 24"

FRONT FENDER BRACE

Rod type as original
 1947-55 Pickup
P4755-8155-A pair 19.95
 1955-59 Chevy GMC Pickup
P5559-8155-A pair 19.95
 1955-59 Pickup
 Left hand, lower 24" of brace
P5559-8155-AL each 44.95
 1955-59 Pickup
 Right hand, Lower 24" of brace
P5559-8155-AR each 44.95
 1960-66 Chevy & GMC
 Left hand, runs along the back side of the fender.
P6066-8155-AL each 39.95
 1960-66 Chevy/GMC Pickup
 Right hand front fender inner brace. Runs along the back side of the fender.
P6066-8155-AR each 39.95



LOWER REAR FENDER PATCH PANEL

Die-stamped steel lower rear fender patch panel. The area often rusted out where running board bolts to front of rear fender shaped to weld in place.
 1947-55 (1st Ser.) Pickup
 Left hand.
P4755-8204-LH each 34.95
 1947-55 (1st Ser.) Pickup
 Right hand.
P4755-8204-RH each 34.95



1947-54

REAR STEEL REPRODUCTION FENDER

Exact duplicate of original.
 Left hand
 1947-54 Chevy/GMC Pickup
P4754-8203-LH each 399.95
 Right hand
 1947-54 Chevy/GMC Pickup
P4754-8203-RH each 399.95



1955-66 Chevy and GMC
 Rear Stepside fender, will fit short or long bed.
P5566-8203-L each 369.95
 1955-66 Chevy or GMC
 Rear Stepside fender, will fit short or long bed.
 Heavy gauge steel.
P5566-8203-R each 369.95



1968-72 Chevy/GMC Pickup
 Left hand Stepside fender
P6872-8203-L each 499.95
 1968-72 Chevy/GMC Pickup
 Right hand Stepside fender
P6872-8203-R each 499.95



CLUTCH HEAD REAR FENDER BOLT KIT

Complete, stainless steel.
 1947-66 Pickup
P4766-8203-K kit 28.95



**Birthday coming up?
 Ask for a Classic Chevrolet Parts
 gift certificate!**



FRONT END SHEET METAL, HEATER PARTS



REAR FENDER BOLT KIT

One kit does two fenders.
Late 1947 - Early 1955
Original stainless steel phillips pan head bolt kit.
P4755-1029-P kit 14.95
Stainless steel phillips truss head w/stand.
1955-59 Pickup (Stepside)
P5559-8203-MB kit 22.95
1960-66 Pickup (Stepside)
P6066-8203-MB kit 19.95
1967-72 Pickup (Stepside)
P6772-8203-MB kit 27.95

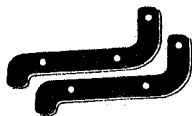

RUNNING BOARD TO REAR FENDER GASKET SET

1947-55 Pickup
P4754-8205-A pair 3.95



RUNNING BOARD SEALS

1947-55 Pickup
Running board to body seals.
P4754-8205-AS pair 19.95
1947-55 Panel, Suburban
Cab to running board seals.
P4754-8205-B pair 24.95

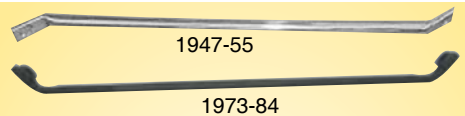

REAR FENDER BRACE

1937-38 Pickup
P3738-8212-A each 66.95
1940-41 Pickup
Original style brace for lower rear of fender.
P4041-8212-A each 32.95
1940-46 Pickup (original on 1946)
Fits under top crown of fender. Original on 1942-46 but will work on all 1940-46 fenders.
P4046-8212-A each 19.95
1947-55 Pickup
Rod type as original.
P4755-8212-A pair 19.95
1967-72 Fleetside
P6772-8212-A set 48.95
1973-84 2wd, 4wd, Ser. 10-30 (Stepside, fender side) 1st design
(14 5/32" o.l.) Curved at both ends.
P7384-8212-B each 14.95

SHOW OFF YOUR TRUCK!

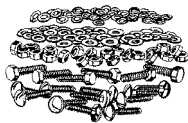

RUNNING BOARD BOLT

Corrosion protected. Kit includes nuts, bolts, and washers.
1936-55 (1/2 ton thru 1 ton)
P4754-8299-MB kit 8.95
1973-78 All
P7378-8228-A each 2.95

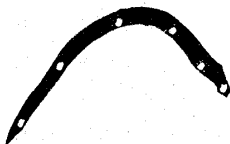

RUNNING BOARD GASKET SET

Running board to fender gaskets.
1939-40 Pickup
P3940-8299-GS set 11.95
1941-46 Pickup
P4146-8299-GS set 11.95



INNER CAB STEP REPAIR PANEL

Does not include rocker panel. Die-stamped steel.
1955-59 Chevy/GMC Pickup
P5559-8299-A each 42.95



INSIDE CAB STEP PLATE AND ROCKER PANEL COMBINATION

Die-stamped steel.
1955-59 Chevy/GMC Pickup
Left hand
P5559-8299-LH each 59.95
1955-59 Chevy/GMC Pickup
Right hand
P5559-8299-RH each 59.95



CAB TO RUNNING BOARD RETAINER SCREW KIT

1947-54 Pickup
P4754-8309-MB kit 1.95



RUNNING BOARD STEP PLATES

(10-7/8" x 5-3/8") Flat style w/bowtie emblem in center.
P-8599-AS pair 49.95



(6-1/2" x 8-1/2") Raised toe plate w/bowtie emblem in center.
P-8599-BS pair 54.95



(11-1/2" x 7-1/2") Raised toe panel, step plate only. Has rubber step inserts. Emblem not included.
P-8599-CS pair 59.95



BOW-TIE RUNNING BOARD STEP PLATE EMBLEM

Fits on step plate.
All
P-8599-C pair 29.95



DEFROSTER CABLE WITH KNOB

Factory fresh air heater, original style.
1947-52 Pickup
P4752-8846-AS each 29.95

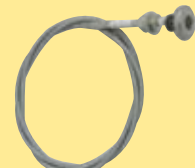

HEATER CABLE WITH KNOB

Recirculator to fresh air, original style.
1953 Pickup
P53-8846-AS each 29.95
1954-55 Pickup
P5455-8846-AS each 29.95

FRONT END SHEET METAL, HEATER PARTS



HEATER DEFROST HOSE KIT

- 2 pcs.
1947-55 1st Series Pickup
P4755-8846-AS kit19.95
1955-59 Pickup
P5559-8846-AS kit14.95
1960-72 Pickup
P6072-8846-AS kit14.95

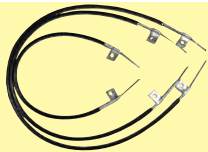

DELUXE HEATER CABLE SET

- Factory control, set of 3.
1955-59 Pickup
P5559-8846-CS set.39.95
1960-63 Pickup
P6063-8846-AS set.49.95
1964-66 Pickup
P6466-8846-AS set.49.95
1967-72 Pickup
P6772-8846-BS set.39.95



SINGLE HEATER CABLE

- E-Z slider cable, non a/c, with economy heater & inner poly liner.
1960-63 Pickup
P6063-8846-BS each16.95



AIR CONDITIONER CONTROL CABLE KIT

- 1967-72 Pickup
P6772-8846-AS kit49.95

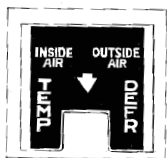

HEATER CONTROL FACE

- 1955-59 Chevy/GMC Pickup
P5559-8849-A each13.95



HEATER CONTROL LENS PLATE

- Deluxe heater control lens metal backing plate. Black.
1955-59 Pickup
P5559-8849-B each3.95



DELUXE SLIDE LEVER CONTROL

- Deluxe slide lever control, with new cables for lever control. Use with factory heater.
1964-66 Chevy Pickup
P6466-8849-AS each229.95

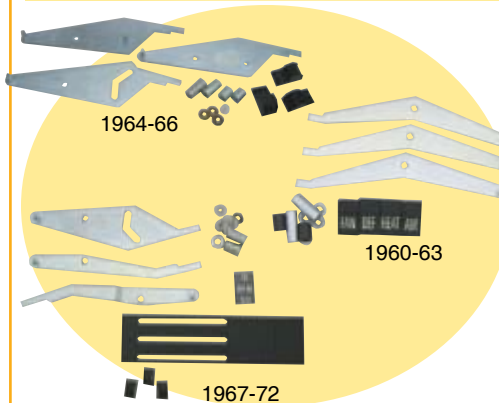

HEATER CONTROL REBUILD KIT

- Replace broken pewter levers with steel, all with 3 slide control.
1960-63 Chevy Pickup
P6063-8849-RK kit59.95
Replace pot metal levers with steel
1964-66 Chevy Pickup
P6466-8849-RK kit59.95
Complete with levers, decals, switches, plates etc. - instructions included.
1967-72 Pickup
Black face.
P6772-8849-RBK kit.49.95
1967-72 Pickup
Chrome plated lever rebuilding kit, without ac.
P6772-8849-RCK set49.95



A/C & HEATER CONTROL ASSEMBLY

- 1967-72 All, Blazer w/ factory air conditioning
P6772-8849-A each189.95



1967-72, chrome

1967-72, black



HEATER CONTROL ASSEMBLY

- 1967-72 Pickup
Chrome faced, rebuilt.
P6772-8849-AS each199.95
1967-72 Pickup
Black faced rebuilt.
P6772-8849-BS each179.95
Heater, defroster, & AC
1974-80 (2wd, 4wd, Ser 10-30, Blazer, Jimmy (exc. H.D.)
P7480-8846-A each99.95

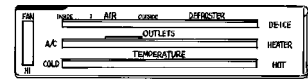

TEMPERATURE CONTROL FACE

- Replacement for factory a/c control w/clips.
1967-72 Chevy/GMC
P6772-8849-B each34.95



SIX WIRE PLUG

- Plugs onto A/C switch in A/C control.
1967-72 Pickup
P6772-8849-PL each2.95



HEATER/AIR CONDITIONER CONTROL SCREW

- 1967-72 Pickup
P6772-8849-SC set.95



WARMER KNOB

- 1947-53 Pickup
Maroon
P4753-8852-K each9.95
1954-55 Pickup
Black
P5455-8852-K each9.95



DELUXE HEATER FAN SWITCH

- 1955-59 Pickup
P5559-8852-A each39.95



FRONT END SHEET METAL, HEATER PARTS



DELUXE HEATER CONTROL LEVERS

- 1955-59 Pickup
P5559-8852-AS pair19.95
 1955-59 GMC only
P5559-8852-GMC pair42.95
 1960-63 Ser 10-30
 Requires 3
P6063-8852-AS each9.95
 1964-66 Ser 10-30 w/ deluxe package
 Air and fan heater control lever.
P6466-8852-AS each19.95
 1964-66 Chevy Pickup
 Complete set of 3 levers.
P6466-8852-AS3 set.29.95



HEAT & A/C CONTROL LEVERS

- 3 piece set
 1967-72 Pickup
P6772-8852-AC3 set32.95

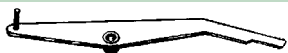

TEMPERATURE CONTROL LEVER

- 1967-72 Ser 10-30 & Blazer (exc. D-D & FFC)
P6772-8852-BS each6.95



DELUXE HEATER LEVER KNOBS

- Set of 4 with screws.
 1955-59 Pickup
P5559-8852-BS set.8.95
 1955-59 GMC only
P5559-8852-KBG set12.95



HEATER CONTROL BEZEL

- Deluxe, chrome .
 1955-59 Pickup
P5559-8852-BZ each49.95

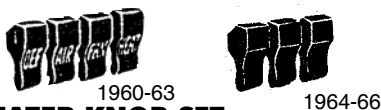

HEATER KNOB SET

- 1960-63 Pickup
 Set of 4, black lettered.
P6063-8852-KBS set9.95
 1964-66 Pickup
 Black heater lever knobs, 3 pcs.
P6466-8852-KBS set7.95



HEATER KNOB

- Auxiliary heater switch knob & defroster lever knob.
 1967-72 Ser 10-20 (Panel & Suburban)
P6772-8852-AS each19.95
 Heater control knob, requires 3.
 1967-72 All & Blazer (exc D-D & factory air)
P7172-8852-AS each4.95

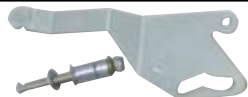

AIR/DE-ICE CONTROL LEVER

- Heat & A/C control top lever, this is the air/de-ice lever.
 1967-72 Pickup w/ AC
P6772-8852-A1 each26.95



HEATER PULL SWITCH CABLE

- Blower switch, replacement pull style with cable.
 1964-66 Chevy Pickup
P6466-8852-B each99.95



BLOWER RESISTORS

- Factory a/c w deluxe heater.
 1964-66 Chevy Pickup
P6466-8852-C each36.95

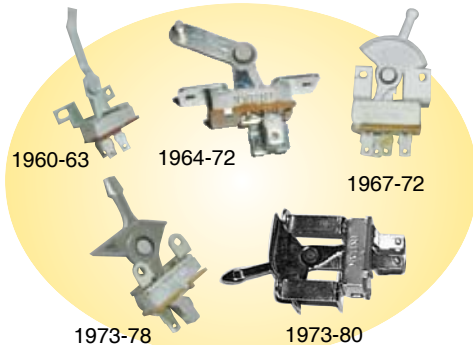

DELUXE HEATER CONTROL SWITCH ASSEMBLY

- 1960-63 Ser 10-30 (Economy & deluxe heater)
P6063-8852-A each59.95
 1964-72 Ser 10-30 (exc. factory air & D-D)
P6472-8852-A each10.95
 1967-72 Ser 10-30 & Blazer (w/ A/C)
P6772-8852-A each16.95
 1973-80 (2wd, 4wd, Ser. 10-30, Blazer, Jimmy (exc. H.D. and Defroster A/C)
P7380-8852-A each10.95
 1973-78 (2wd, 4wd, Ser. 10-30, Blazer, Jimmy w/ H.D. Heater, AC)
 1978-82 (2wd, 3wd, Ser. 10-30, w/ manual AC Temp Control)
P7382-8852-B each15.95



HEATER CORE

- 1960-63 Pickup (w/ recirculating air)
P6063-8854-A each79.95
 1960-66 Pickup (w/ out air)
P6066-8854-A each69.95
 1964-66 Pickup (w/ air)
P6466-8854-A each69.95
 With fittings, w/o air.
 1967-75 Ser 10-30 & Suburban
 1969-72 Blazer, Jimmy
P6772-8854-A each69.95
 With factory air condition.
 1967-72 Pickup (w/ air)
 1969-72 Blazer, Jimmy (w/ air)
P6772-8854-B each69.95



SWITCH CONNECTOR REPAIR KIT

- 3 terminal connector.
 1960-72 Pickup
P6072-8855-RK each12.95

**Can't find it?
 Call us - we'll get it
 for you!**



BLOWER RESISTORS

With non-air economy heater.
 1964-66 Pickup w/o A/C & economy heater
P6466-8855-B each39.95
 1979-84 (2wd, 4wd, Ser. 10-30, w/ HD Heater)
P7984-8855-A each16.95



HEATER BLOWER MOTOR GASKET

1964-72 Pickup
P6472-8855-G each9.95



HEATER BLOWER CASE GASKET

1960-63 Ser 10-30 w/ air flow
P6063-8857-GA each19.95

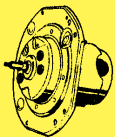

A/C & HEATER BLOWER MOTOR

A/C & heater blower motor (w/integral A/C)
 1964-77 Pickup, Blazer
F6777-8857-A each39.95

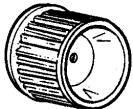

HEATER FAN

This is the squirrel cage.
 1972-77 (exc AC)
 1978-81 (exc HD heater) Pickup, Suburban & Blazer
F6777-8857-AS each19.95

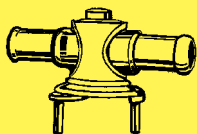

WATER SHUT OFF VALVE

Fits in heater hose. Hose insert type.
 1938-75 All w/ 5/8" Hose
P3872-8866-A each39.95

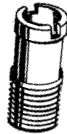

HEATER HOSE COUPLING NIPPLE

Fits in intake.
 1938-72 All, Blazer
P3872-8866-B each19.95

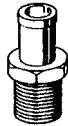

1960-64



1960-70

HEATER VALVE NIPPLE

Fits 1/2" pipe, short style. Fits in intake.
 1960-64 Chevy Pickup (all)
 1969-70 (8 cyl) w/ hex nipple
P6070-8866-A each5.95
 Fits 5/8" hose, long nipple.
 1960-70 Chevy Pickup (8 cyl)
P6070-8866-B each8.95



HEATER HOSE CONNECTOR

"T" type. Fits 3/4 in. hose.
 1964-66 Chevy Pickup
 1965-75 Chevy Pickup ("Auxiliary Heater")
P6475-8866-A each7.95



UNDER HOOD LAMP ASSEMBLY

1977-78 (2wd, 4wd, Ser. 10-30, Blazer, Jimmy)
P7778-8890-A each26.95



A/C COMPRESSOR O-RING KIT

1959-89 All GM products
P-8929-K set12.95

We appreciate your business!

CHEVROLET Ave.

WE USE Genuine CHEVROLET PARTS

CHEVROLET PARKING ONLY

WAXHOME POLISH

Plastic and Emblem Adhesive

WE USE CHEVROLET PARTS

GAS TANK ETCH

MR. BUFFER

Find these great items in our Accessories & Decals section!





BODY MOUNTING, AIR COND., DASH PARTS



ADHESIVE BACKED BODY TO FRAME WEBBING

This is a special body to frame cushion with pressure sensitive adhesive on the back. Just peel & stick. 20 ft x 2" wide.

- B-9023-112 each**26.95
20 ft x 2" wide x 1/8" thick
- B-9023-2 each**28.95

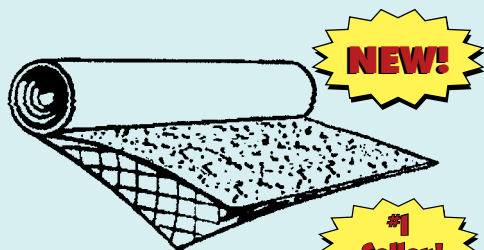

FOIL NOISE AND HEAT INSULATION MATERIAL

Reflective foil insulation consists of two layers of polyethylene bubble film sandwiched between two layers of 99.9% pure aluminum foil, making a structure 5/16" thick. Temperature range: -60°F to 180°F. Works great for insulating firewalls, headliners, floor pans, trunk area, door panels, kick panels, rumble seat area, etc. Cut and form into needed shapes using scissors and contact cement or weatherstrip adhesive. 48"W x 72"L x 5/16"T.

- B-9023-S each**29.95



BODY INSULATION SHEETING

Tar coated sound deadening sheet. 3 ft. wide by 8" long x 1/16" thick.

- B-9023-F30 each**7.95

Nancy keeps our office under control with a smiling face!

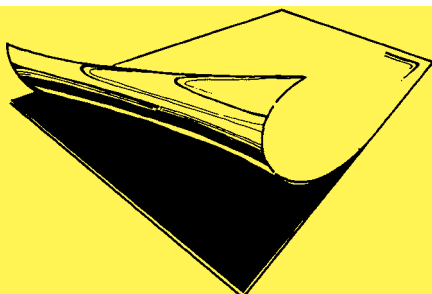

ADHESIVE BACKED FOIL INSULATION SHEETING

Heat resistant & water proof. Sound deadening material installs under any place on the car (headliner, body, door panels, floor, deck lid, trunk, firewall etc.). This is a must for a restoration project that should be done right! Layered foil dampening pad with an adhesive side for easy and quick installation. No other adhesive required. 32" x 54" sheet.

- B-9023-FSS each**29.95



BODY MOUNTING SHIM

Cushion steel shim. (1" hole centered & one 7/8" wide slot in one end).

- 1938-47 All
- P3847-9023-SHA each**4.95



FRONT CAB MOUNT PADS

- 1947-54 Pickup
- P4754-9023-A pair**5.95



REAR CAB MOUNT BUSHINGS

- Set of 8.
- 1947-55 Pickup
- P4754-9023-K kit**10.95



CAB MOUNT BOLT KIT

- Contains correct sized washers, bolts, and nuts).
- 1947-54 Pickup
- P4754-9023-MBA kit**3.95
- 1967-72 Pickup
- P6772-9023-MBA set**19.95



BODY MOUNT PAD KIT

- 1947-54 Panel, Suburban
- P4754-9023-PS kit**14.95

See Street Rod section for urethane bushing kits

- 1939-46
- 1949-55
- 1963-66
- 1955-59
- 1967-72 1/2 Ton

CAB MOUNT SET

Complete with bushings, washers, bolts & blocks.

- 1939-46 Pickup
- P3946-9023-KA set**54.95
- 1947-48 Pickup
- P4748-9023-K set**29.95
- 1949-55 Pickup (1st series)
- P4955-9023-K kit**19.95
- 1955-59 Pickup (2nd Series)
- P5559-9023-AS set**26.95

- 1963-66 Pickup, 2wd (OEM rubber)
- P6366-9023-MK kit**69.95
- 1967-72 Pickup 1/2 ton, 2wd (No bolts included)
- P6772-9023-AS set**59.95
- 1967-72 1/2 Ton Pickup
- P6772-9023-SET set**85.95

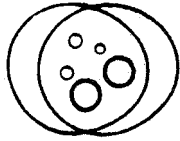

A/C COMPRESSOR SEAL KIT

Consists of 8 seals "o" rings.
1973-78 Ser. 10-30, Blazer, Jimmy (8 cyl)
P6781-9170-SK each17.95



A/C COMPRESSOR SWITCH

Controls a/c compressor 3 terminal. Located under glove box.
1964-66 Chevy Pickup
P6466-9171-BK each59.95
1967-72 Pickup
P6772-9171-BK each59.95



FRONT A/C COMPRESSOR MOUNTING BRACE

Front adjusting bracket.
1967-72 Pickup
F6768-9171-AB each24.95



REAR AIR CONDITIONING COMPRESSOR MOUNTING BRACE

1968-72 Chevy Pickup
F6768-9171-BB each15.95



FUSE BLOCK GASKET

On firewall.
1967-72 Pickup
P6772-9172-G each1.95



CHROME AIR CONDITIONER VENT DEFLECTOR BALL

1967-72 Pickup
P6772-9186-A each9.95



A/C BALL GASKET SET

(4 pc. set)
1967-72 Pickup
P6772-9186-AS set.4.95



A/C CENTER VENT ASSEMBLY

Chrome
1967-72 Chevy Pickup
P6772-9186-C each26.95



CENTER VENT HOSE ADAPTER

1967-72 Pickup
P6772-9186-U each49.95

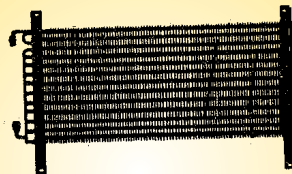

A/C CONDENSER

Condenser only.
1967-72 Pickup
1972 Suburban (w/ single A/C)
P6772-9190-A each199.95

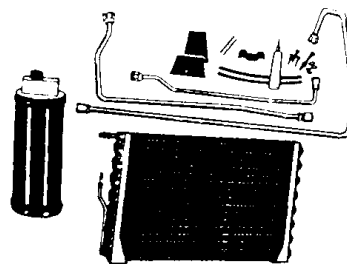

CONDENSER DRIER TUBES KIT

Includes factory A/C condenser, drier, and tube kit. For use with all refrigerants.
1964-66 Chevy/GMC Pickup (w/ factory AC)
P6466-9190-SET set.259.95

See complete air conditioning systems in Street Rod section



POA VALVE UPDATE KIT

Used to convert A/C system to a cycling clutch system as found on late model vehicles.
1967-72 All with factory A/C
For use with **R134A freon.**
P6772-9198-134 Kit114.95
1967-72 Chevy/GMC Pickup, Blazer, and Suburban
For use with **R-12 freon.**
P6772-9198-R12 Kit114.95



A/C WIRING HARNESS & VACUUM HOSE GROMMET

In dash.
1972 All, Blazer (w/ factory AC)
P72-9198-G each1.95

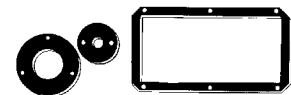

DELUXE HEATER GASKET SET

1947-54 Pickup
P4754-9210-GS set11.95
1963-66 Pickup
P6366-9210-GS set9.95

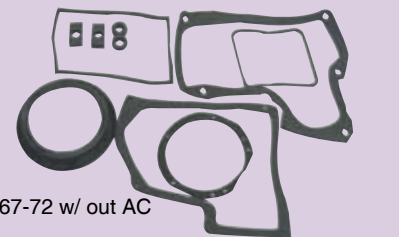

1967-72 w/ out AC

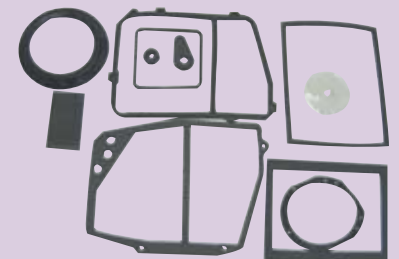

1967-72 w/ AC

HEATER & A/C GASKET SET

Includes blower motor seal.
1967-72 Chevy Pickup w/ out AC
P6772-9210-AS set of 624.95
1967-72 Pickup, Blazer w/ AC
P6772-9210-BS set of 1029.95



BODY MOUNTING, AIR COND., DASH PARTS

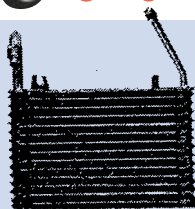

AIR CONDITIONER EVAPORATOR CORE

Includes fittings.

1971-72 Ser 10-30 & Blazer

P7172-9210-A each229.95

1972 Ser 10-20 (Suburban w/ roof mounted air)

1979-84 (2wd, 4wd, Ser 10-20)

1973-78 (2wd, 4wd, Ser 10-30, Suburban (w/ overhead AC))

P72-9210-A each239.95

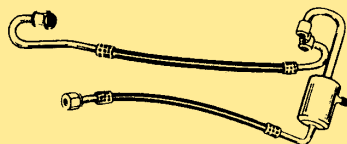

A/C HOSE W/MUFFLER

Use with R12.

1967-72 Pickup

P6772-9211-AS each139.95

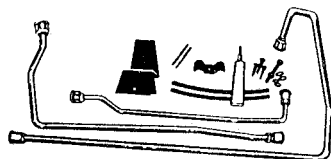

AIR CONDITIONING TUBE KIT

1967-72 Pickup

P6772-9211-TK set.59.95

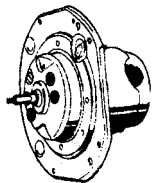

BLOWER MOTOR (NEW)

1960-63 Chevy/GMC Pickup

P6063-9215-A each59.95

1964-72 Chevy/GMC

1973-76 All -front

1977 All front (w/ 7/8" vent hole)

1978-83 All -front (exc HD heater & AC)

P6472-9215-A each29.95

1971-78 All - rear

P7183-9215-A each44.95



A/C COMPRESSOR HIGH PRESSURE HOSE

1967-72 Pickup

P6772-9220-A each32.95

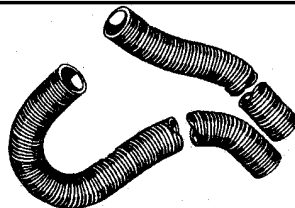

DEFROSTER HEATER FRESH AIR & A/C DUCT HOSE

Flexible wire enforced, comes in 3 foot lengths only.

(1-1/2" Diameter)

B-9260-112 3/ft19.95

(1-3/4" Diameter)

B-9260-134 3/ft19.95

(2" Diameter)

B-9260-200 3/ft19.95

(2 1/2" Diameter)

B-9260-212 each19.95

(2 3/4" Diameter)

B-9260-234 stick24.95

(3" Diameter)

B-9260-300 3/ft24.95

(3 1/2" Diameter)

B-9260-312 3/ft24.95

(3 1/4" Diameter)

B-9260-314 3/ft24.95

(3-3/4" Diameter)

B-9260-334 3/ft27.95

(4" Diameter)

B-9260-400 3/ft29.95

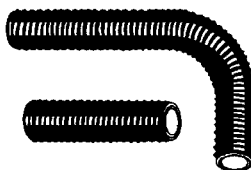

AC DEFROST & HEATER HOSE SET

1967-72 Pickup

P6772-9260-AS set of 659.95

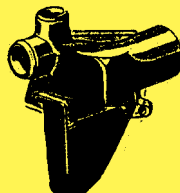

HEAT & AC DUCT

With valve.

1967-72 Pickup (w/ AC)

P6772-9262-A each119.95



CHROME A/C OUTLET HOUSING

Complete with felt liner.

1967-72 Chevy/GMC, All with factory air

Left hand

P6772-9264-CLH each24.95

1967-72 Chevy/GMC All with factory air

Right hand

P6772-9264-CRH each24.95



A/C VENT BALL HOLDER

Black with felt liner.

1967-72 Chevy Pickup

Left hand

P6772-9264-LH each19.95

1967-72 Chevy Pickup

Right hand

P6772-9264-RH each19.95



AC HIGH SPEED FAN RELAY

Replacement

1967-72 Chevy Pickup

P6772-9277-A each19.95



A/C CONTROL BEZEL SET

(3 bezels)

1963-66 Chevy/GMC

P6366-9279-AS set.49.95



A/C VACUUM ACTUATOR

Fits on outer firewall.

1967-72 Chevy Pickup, Suburban

1969-72 Blazer

P6772-9280-A each54.95

We appreciate your business!



FRESH AIR VACUUM ACTUATOR

Metal, fits on passenger side kick panel.
1967-72 Chevy/GMC

P6772-9280-B each54.95



VACUUM CANISTER

1967-72 Chevy Pickup (w/ AC)

F6777-9281-A each24.95

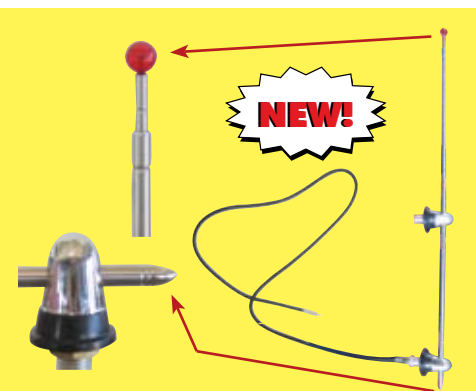

UNIVERSAL SIDE MOUNT ANTENNA

Real nostalgia! Mounts on side of cowl- neat early day accessory. New style with nostalgic red ball, new & improved quality. Has a bullet cap on the bottom of the mast.
Universal - fits all

P-9645-SMA each39.95

Find your t-shirt on page 14!

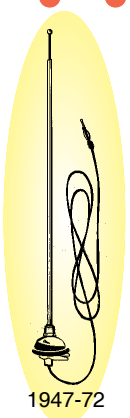

1947-72

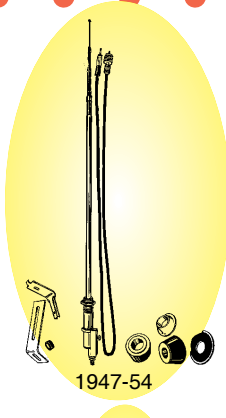

1947-54

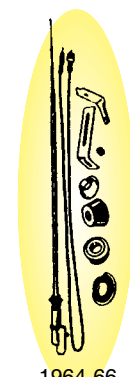

1964-66



1967-72, with whip

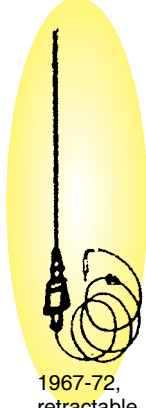

1967-72, retractable

RADIO ANTENNA

1947-54 Chevy Pickup
Telescopic stainless steel radio antenna, complete with mounting hardware.

P4754-9645-A each69.95

1947-72 Chevy Pickup
Replacement, not original.

P5559-9645-RAR each22.95

1955-59 Chevy/GMC Pickup (original style)

P5559-9645-A each69.95

1960-62 Chevy/GMC All (original style)

P6062-9645-A Kit89.95

1963 Chevy/GMC All (original style)

P63-9645-A Kit89.95

1964-66 Chevy Pickup
Includes coaxial cable.

P6466-9645-FA each59.95

1967-72 Chevy Pickup
With stationary whip.

P6772-9645-A each49.95

1967-72 Chevy Pickup, All
Retractable, complete with hardware.

P6772-9645-B each69.95



WINDSHIELD RADIO ANTENNA CABLE

1979-84 Ser 10-30
1973-78 Ser 10-30, Blazer, Jimmy

P7384-9647-A each7.95

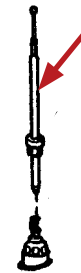

RADIO ANTENNA ROD & MAST

1976-78 Ser 10-30, Blazer, Jimmy (w/ AM/FM)

P7678-9647-A each19.95

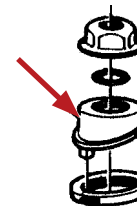

RADIO ANTENNA BEZEL

1979 (2wd, 4wd, Ser 10-30)
1973-78 (2wd, 4wd, Ser 10-30, Blazer, Jimmy)

P7379-9647-A each13.95



RADIO BEZEL GASKETS

1947-53 Chevy Pickup
P4753-9650-BG pair2.95



LOWER RADIO SPACERS

1947-53 Chevy Pickup
P4753-9650-LRP pair3.95



RADIO BEZELS

Between knobs and dash.
1947-53 Chevy Pickup
P4753-9650-RB pair19.95



RADIO KNOB & BUTTON KIT

Tan, 5 pcs.
1947-53 Chevy Pickup
P4753-9650-RBK kit24.95



BODY MOUNTING, AIR COND., DASH PARTS



RADIO DIAL HOUSING

Maroon
1947-53 Chevy Pickup
P4753-9650-RDH each29.95



RADIO FLIPPER

1947-53 Chevy/GMC Pickup
With ears.
P4753-9650-RFA each8.95
1947-53 Chevy/GMC Pickup
Without ears.
P4753-9650-RFB each8.95



RADIO SPEAKER SPONGE GASKET

1947-53 Chevy Pickup
P4753-9650-RSS each11.95

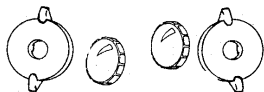

RADIO KNOB KIT

Tan, two knobs and two flippers.
1947-53 Chevy Pickup
P4753-9650-TK kit24.95



UPPER RADIO SPACERS

1947-53 Chevy Pickup
P4753-9650-URP pair.3.95



RADIO SPEAKER COVER

Cardboard.
1947-54 Chevy Pickup
P4754-9650-SCC each8.95



RADIO DASH TRIM PLATE

Cast as original.
1954-55 Chevy Pickup Only
P5455-9650-TP each34.95



RADIO FACE PLATE

1947-49 Chevy Pickup
White letters with tapered back case.
P4749-9650-FPA each19.95
1947-49 GMC Pickup
Red letters with tapered back case.
P4749-9650-FPB each19.95
1950-53 Chevy Pickup only
White letters with flat back case.
P5053-9650-FPB each19.95
1950-53 GMC Pickup
Red letters with flat back case.
P5053-9650-FPG each19.95
1954-55 Chevy Pickup
White letters on glass plate, as original.
P5455-9650-FPC each17.95
1954-59 GMC Pickup
White letters on glass plate, as original.
P5459-9650-FPG each17.95
1955-59 Chevy Pickup
White letters on glass plate, as original.
P5559-9650-FPD each17.95



RADIO KNOB KIT

1954-55 Chevy Pickup
Black
P54-9650-BK set of 429.95
1954-55 GMC Pickup
Grey
P54-9650-GK set of 419.95
1955-59 Chevy Pickup
Chrome, 2 pc kit.
P5559-9650-CK kit19.95
1960-63 Chevy Pickup, Black (stainless steel)
Black & stainless steel.
P6063-9650-DK each6.95
1964-66 Chevy Pickup, Black (stainless steel)
Black & stainless steel.
P6466-9650-DK each8.95



RADIO SPEAKER ASSEMBLY

1955-59 Chevy Pickup
P5559-9650-RS each21.95

Find complete Radios and Speakers in the Street Rod section!



RADIO SPEAKER COVER

Mounts above windshield, as original.
1955-59 Chevy Pickup
Chrome.
P5559-9650-CH each59.95
1955-59 Chevy Pickup
Painted.
P5559-9650-PT each34.95



DASH KNOB

Fits radio, heater & vent, 3/16" hole.
1955-59 Pickup
P5559-9650-DK each9.95



RADIO KNOB FLIPPER

Chromed plastic.
1955-59 Pickup
P5559-9650-RKF pair.19.95

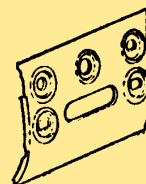

RADIO DASH FACE REPAIR PANEL

Repairs dash to original oval radio cutout. Made of stamped steel.
1955-59 Chevy Pickup
P5559-9650-RP each79.95



RADIO SELECTOR BAR

(am/fm)
1968-72 Chevy/GMC
P6872-9650-RSB each24.95



AM-FM RADIO LENS

AM-FM radio lens w/Delco in script.
1969-72 Pickup
P6972-9650-L each9.95



ACCESSORY VENT SHADES

Fits outside of door above door glass. Stainless steel.

- 1951-55 Pickup
- P5154-9694-PR pair** **39.95**
- 1955-59 Pickup
- P5559-9694-AS pair** **39.95**
- 1960-63 Pickup
- P6063-9694-AS pair** **39.95**
- 1964-66 Pickup
- P6466-9694-AS pair** **39.95**
- 1967-72 Pickup
- P6772-9694-AS pair** **39.95**
- 1973-87 Pickup
- P7387-9694-AS pair** **39.95**



DASH KNOB KIT

Exact duplicate of originals.

- 1930-31 Pickup
- Complete with choke, throttle, lights & spark.
- P3031-9700-K kit** **34.95**
- 1933-35 Pickup
- Complete with choke, throttle, lights & spark.
- P3355-9700-K kit** **29.95**
- 1936-39 Pickup
- Complete with choke, throttle, lights & spark.
- P3639-9700-K kit** **29.95**
- 1940-46 Pickup
- Rose-tan in color. Complete with choke, throttle, lights & spark.
- P4046-9700-K kit** **29.95**
- 1947-49 Chevy Pickup
- Complete with choke, throttle, light, warmer and chrome wiper knob.
- P4749-9700-K kit** **44.95**
- 1950-53 Chevy Pickup
- Maroon. Complete with wiper, warmer, throttle, choke, lights.
- P5053-9700-K kit** **44.95**
- 1954 Pickup
- Complete with choke, throttle, lights & brake.
- P54-9700-K kit** **36.95**
- 1955-59 Pickup
- Black. Complete with choke, throttle, lights & radio.
- P5559-9700-KB kit** **29.95**



CIGARETTE LIGHT KNOB

- Black
- 1954-55 Chevrolet
- P54-9700-C each** **8.95**



CIGARETTE LIGHTER ELEMENT

- 1955-59 Pickup
- P5559-9709-E each** **17.95**
- 1964-66 Pickup
- 1979-84 (2wd, 4wd, Ser 10-30, w/ out knob (Casco)
- 1973-78 All, Blazer and Jimmy
- P6466-9709-A each** **19.95**
- 1979 Ser 10-30
- With cup & screw (Rochester).
- F79-9709-A each** **19.95**
- 1979-84 Ser 10-30
- With knob (Casco)
- P7984-9709-A each** **14.95**

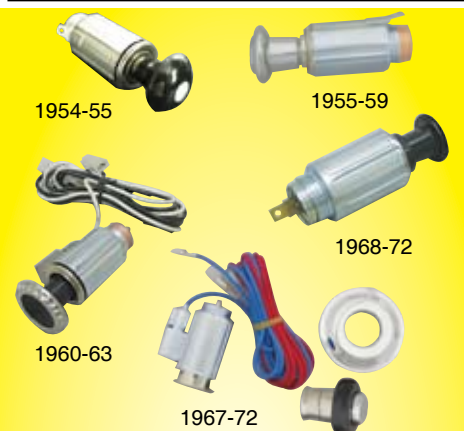

CIGARETTE LIGHTER ASSEMBLY

- Cigarette lighter receptacle with element, 12v, maroon and stainless steel.
- 1947-53 Pickup
- P4753-9709-A each** **19.95**
- Black
- 1954-55 Chevy
- P5455-9709-A each** **19.95**
- Cigarette lighter w/original knob and housing, chrome.
- 1955-59 Pickup
- P5559-9709-K each** **19.95**
- Complete with receptacle and element. Black and stainless.
- 1960-63 Pickup
- P6063-9709-A set** **29.95**
- Complete w/element & knob.
- 1964-66 Pickup
- P6466-9709-B set** **29.95**
- 1967-72 Pickup
- P6772-9709-A each** **19.95**
- 1968-72 Ser 10-30 & Blazer (Exc. FFC & D-D)
- 1978 All (Casco)
- P6872-9709-A each** **14.95**



LIGHTER HOUSING ASSEMBLY

- 1963-72 All & Blazer
- P6372-9709-A each** **12.95**



INSTRUMENT PANEL LIGHT BULB AND SOCKET

- 1967-72 Pickup, Blazer, and Suburban.
- P6772-9744-A each** **2.95**

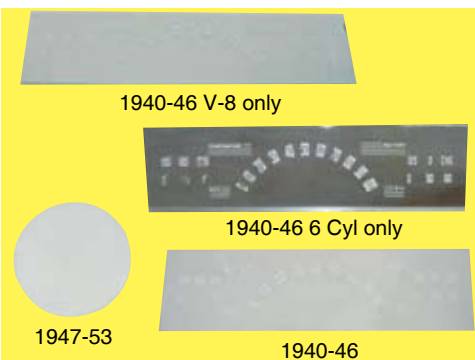

INSTRUMENT CLUSTER LENS

- 1940-46 Chevy Pickup (6 Cyl only)
- Glass, 30 lb. oil - 212 temp.
- P4046-9748-A6 each** **19.95**
- 1940-46 Chevy Pickup (V-8 only)
- Glass, 60 lb. oil - 220 temp.
- P4046-9748-A8 each** **19.95**
- 1940-46 GMC only
- P4046-9748-GMC each** **19.95**
- Circular glass discs.
- 1947-53 Chevy & GMC
- P4753-9748-A each** **4.95**
- 1954-55 Chevy Pickup
- P5455-9748-A each** **5.95**

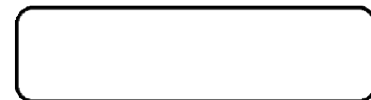

DASH GAUGE GASKET

- 1940-46 Pickup
- P4046-9748-GG each** **2.95**



SPEEDOMETER FACE

- Dash panel lens.
- 1955-59 Chevy Pickup
- P5559-9748-SF each** **39.95**



BODY MOUNTING, AIR COND., DASH PARTS



INSTRUMENT PANEL GAUGE FACE

For use w/warning lights, exact duplicate of original.
1964-66 Pickup

P6466-9748-A each59.95

For use with gauges, exact duplicate of original.
1964-66 Pickup

P6466-9748-B each59.95



1967-72 Ser 10-30 & Blazer
w/ gauges



1967-72 Chevy GMC



1967-72 Chevy/GMC

INSTRUMENT PANEL LENS

1967-72 Chevy/GMC Pickup, Blazer, And Suburban.

For use with 3 hole dash, warning lights.

P6772-9748-3 each49.95

Used with gauge package and tach.

1967-72 Ser 10-30 & Blazer w/ tachometer

P6772-9748-A each49.95

1967-72 Ser 10-30 & Blazer w/ gauges

P6772-9748-B each49.95

1967-72 Chevy GMC

P6772-9748-C49.95

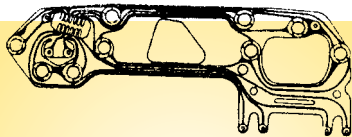

PRINTED CIRCUIT BOARD

Used with gauges. no tach.
1967-72 Pickup

P6772-9748-CA each69.95

For instrument cluster with factory tachometer.
1967-72 Pickup

P6772-9748-CB each69.95

Use w/warning lights (for use with 3 hole dash)
1967-72 Chevy/GMC

P6772-9748-CC each79.95



SPEEDO & GAUGE GASKETS

1947-54 Pickup

P4754-9749-G set.3.95

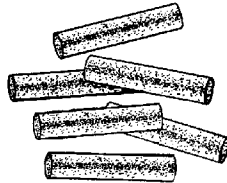

INSTRUMENT BEZEL CUSHIONS

Dash instrument lens bumper, fits between glass and bezel.

1967-72 Pickup

P6772-9749-AS set of 61.95

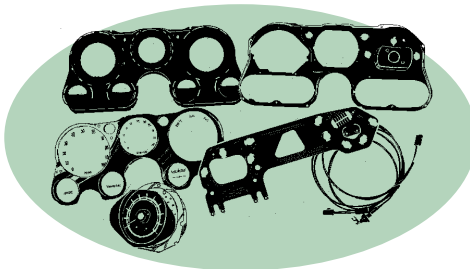

TACHOMETER CONVERSION KIT

Includes: tachometer gauge, wiring harness, hardware, and instructions.

1963-66 Chevrolet

P6366-9750-KT Kit199.95

Comes complete with everything you need to convert your original gauge package to a factory tach. Package includes tach, backing plate, tach rear cover, lens, wiring harness, and instructions, made in the USA.

1967-72 Pickup

P6772-9750-KT kit299.95

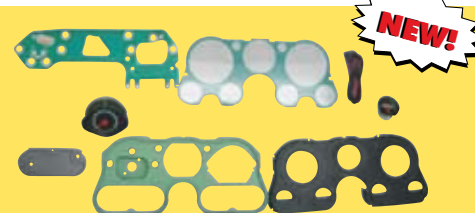

NEW!

TACHOMETER AND VACUUM CONVERSION KIT

This will convert a non tach, and non vacuum dash gauge cluster, to one which will accommodate both gauges.

1967-72 Chevy GMC Pickup

P6772-9750-KTV each329.95

**Why wait?
Don't punish your
truck any longer.
Get it now!**



NEW!

VACUUM GAUGE CONVERSION KIT

Everything you need to convert your gauge cluster accommodations for a vacuum gauge. Lens, gauge, back plate, and housing.

1967-72 Pickup, Blazer, and Suburban

P6772-9750-KV Kit.199.95



TACHOMETER

Factory style tachometer gauge, reproduction of original, made in USA.

1967-72 Pickup (8 cyl)

P6772-9750-TC each129.95

NEW!



VACUUM GAUGE

1967-72 Chevy Pickup

P6772-9760-V each79.95



1950-53

NEW!



1955-59



1967-72

SPEEDOMETER GAUGE ASSEMBLY

Complete with odometer.

1947-49 Chevy Pickup

0-80 mph.

P4749-9761-A each139.95

1950-53 Chevy Pickup

0-90 mph.

P5053-9761-A each139.95

1955-59 Chevy Pickup

P5559-9761-A each139.95

1967-72 Ser. 10-30 & Blazer (Exc. D-D & speed warning systems)

P6772-9761-A each129.95



NEW!



SPEEDOMETER CLUSTER

0-80 MPH. Complete assembly.
1947-49 Chevy Pickup
P4749-9761-ASSY each 199.95
0-90 MPH. Complete assembly.
1950-53 Chevy Pickup
P5053-9761-ASSY each 199.95



CONTROL CABLE USED WITH THE RPO (SPEED WARNING INDICATOR)

High quality reproduction!
1967 All
F6769-9762-SC each 39.95

NEW!



1947-49, 6 volt



1947-49, 12 volt



1950-53, 6 volt



1950-53, 12 volt

GAUGE CLUSTER ASSEMBLY

Cluster assembly. 6 volt, 6 cylinder. 0-30 lbs. oil, 0-220 temperature with red needles.
1947-49 Pickup
P4749-7962-6V each 349.95
Cluster assembly. 12 volt, 8 cylinder. 0-60 lbs. oil, 0-220 temperature with red needles.
1947-49 Pickup
P4749-7962-12V each 349.95
Cluster assembly. 6 volt, 6 cylinder. 0-30 lbs. oil, 0-220 temperature with white needles.
1950-53 Pickup
P5053-7962-6V each 349.95
Cluster assembly. 12 volt, 8 cylinder. 0-60 lbs. oil, 0-220 temperature with white needles.
1950-53 Pickup
P5053-7962-12V each 349.95



SPEEDOMETER CABLE GROMMET

Through firewall.
1936-46 Pickup
P3646-9775-G each 4.95
1947-59 Pickup
P4754-9775-SCG each 1.95



FIREWALL GROMMET

(4-hole)
1947-49 Pickup
P4749-9775-FGA each 3.95
1950-59 Pickup
P5054-9775-FGA each 3.95



HEATER HOSE GROMMET

Deluxe. Through firewall.
1947-54 Pickup
P4754-9775-HG each 3.95



IGNITION WIRE GROMMET

Main supply and ignition wire firewall grommet.
1947-54 Pickup
P4754-9775-IWG each 1.95



WIRING HARNESS GROMMET

Main wiring harness firewall grommet.
1947-59 Pickup
P4754-9775-MWH each 2.95



VACUUM HOSE GROMMET

Firewall grommet
1947-54 Pickup
P4754-9775-VHG each 1.95

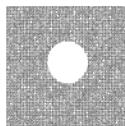

EMERGENCY BRAKE ROD SEAL

Through firewall
1955-59 Pickup
P5559-9775-BRS each 2.95



GROMMET

1955-59 (Speedoflex shaft grommet & ammeter to starting switch wiring harness grommet)
P5559-9775-G each 2.95



GROMMET/BUMPER KIT

Includes firewall, hood, and door grommets and bumpers. (large kit) 34 pieces.
1955-59 Pickup
P5559-9775-GK kit 44.95



LARGE FIREWALL GROMMET

1955-59 Pickup
P5559-9775-LFG each 3.95



SPEEDO CLUSTER GROMMET

(4-hole)
1955-59 Pickup
P5559-9775-SCG each 2.95



FIREWALL GROMMET SET

(6 pcs)
1960-66 Pickup
P6066-9775-AS set 19.95

Check out Street Rod for a large selection of gauges and instrument panels!

Here's Cindy, hard at work in the office.... Service with a smile!





BODY MOUNTING, AIR COND., DASH PARTS



WIRING HARNESS GROMMET

1960-66 Pickup
Large
P6066-9775-LWHG each3.95
1960-66 Pickup
Small
P6066-9775-SWHG each3.95



GROMMET

(See below applications)
1962-69 All & Blazer (dome lamp wire assembly grommet)
1965-69 All & Blazer (radio lead in cable assembly grommet)
1960 Ser 10-30 (exc. 4wd - directional signal grommet)
P6069-9775-G each4.95
Oil pressure gauge pipe grommet
1967-72 Ser 10-30 All, w/ tach, gauges, speedo shaft grommet
1973-77 All, Blazer, Jimmy
P6772-9775-G each1.95
1971-72 Ser 10-30 (parking brake inter. cable grommet)
1973 (2wd, Ser 20 w/ 127" W.B)
1974-78 (2wd, 10-30 (131.5, 135.5, 164.5)
1974-78 (4wd, Ser 30 (4dr cab)
1973 (2wd, Ser 30, w/ 157" w.b.)
1973 (2wd, Ser 30, (stake rack w/ 133" w.b.)
1974-77 (stake rack w/ 159.5" w.b.)
1974-78 (4wd, Ser 30 (159.5 w.b.)
P7172-9775-G each4.95
1971-72 Ser 10-30 w/ AC or Camper wiring (camper harness wire grommet, fuel tank meter selector switch wire grommet)
P7172-9775-GB each4.95
(.97 id x 1.19 od, .64 hole)
1973-77 (2wd, 4wd, Ser 10-30, Pickup, Blazer, Jimmy (tail & stop lamp rear wire, horn wire)
1978-81 All
P7381-9775-A each4.95



SPEEDOMETER SHAFT GROMMET

(2 7/32 x 7/32 x 9/32)
1979-82 (2wd, 4wd, Ser 10-30)
F7681-9775-A each4.95



WIRING GROMMET

(1.25 i.d. x 2 o.d. 1.5 hole .12 pnl)
1979-81 (2wd, 4wd, Ser 10-30)
F7681-9775-B each19.95

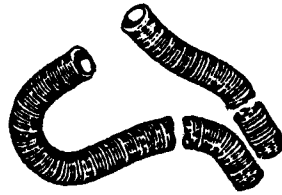

A/C DUCT HOSE KIT

4 pieces
1967-72 Chevy Pickup
P6772-9779-AS kit29.95



DEFROSTER HOSE (3-1/4")

(3-1/4") defroster hose - 6 ft. long
1967-72 All
P6772-9779-EA each49.95



CHROME PLATED DEFROST VENT

1967-72 Chevy/GMC All Ser. 10-30
Left hand
P6772-9779-CLH each12.95
1967-72 Chevy/GMC All Ser. 10-30
Right hand
P6772-9779-CRH each12.95

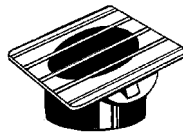

HEATER/DEFROSTER OUTLET

1969-72 Ser 10-30 All (exc. D-D & FFC)
Left hand
P6972-9779-LH each8.95
1969-72 Ser 10-30 All
Right hand
P6972-9779-RH each8.95



HEATER 'S' DUCT FOR A/C

Plastic.
1967-72 Pickup
P6772-9786-D each29.95



COWL VENT KNOB

1940-46 Pickup
Rose tan
P4046-9787-CV each10.95
1947-53 Pickup
Maroon
P4753-9787-CV each6.95
1954-55 (1st Series) Pickup
Black
P54-9787-CV each6.95



SIDE VENT KNOB

1947-50 Pickup
P4750-9787-SV each12.95

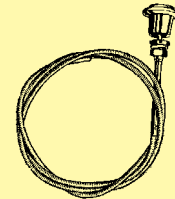

AIR VENT CABLE & KNOB ASSEMBLY

1955-59 Pickup
P5559-9787-AS each29.95



SIDE VENT CONTROL ASSEMBLY

1955-59 Pickup
Left hand, black knob
P5559-9787-BLH each29.95
1955-59 Pickup
Right hand, black knob
P5559-9787-BRH each29.95
1955-59 Pickup
Left hand chrome knob
P5559-9787-CLH each29.95
1955-59 Pickup
Right hand chrome knob
P5559-9787-CRH each29.95
1960-63 Pickup
Left hand black & stainless knob
P6063-9787-BLH each29.95
1960-63 Pickup
Right hand, black & stainless knob
P6063-9787-BRH each29.95



AIR VENT KNOB

Air vent valve operating rod knob. Requires 2.
1969-72 All (exc. FFC & D-D)
P6972-9787-A each5.95



HEATER CONTROL VALVE

1955-58 Truck
B5556-9795-A each52.95

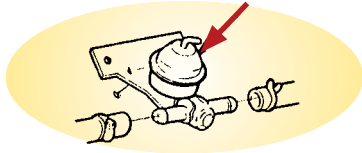

HEATER WATER TEMP VALVE

Heater vacuum water shut-off valve (mounted on skirt).
1970-72 All w/ factory AC
1969-72 Suburban w/ roof AC
F6970-9795-A each39.95



CARGO LIGHT MOUNTING GASKET

1967-72 Pickup
P6772-9988-MTG each11.95



CARGO LAMP SWITCH

1969-72 Chevrolet, GMC
P6972-9988-A each15.95



CARGO LAMP BULB

1970-74 All w/ cargo lamp
P7072-9988-A each3.95



CARGO LAMP SWITCH SCREWS

1970-72 Pickup
P7072-9988-SC set.95



CARGO LAMP LENS GASKET

1973-84 (2wd, 4wd, Ser 10-30)
P7384-9988-A each7.95



CARGO LAMP MOUNTING PAD

1973-84 (2wd, 4wd, Ser 10-30)
P7384-9988-C each5.95

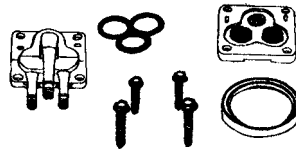

WINDSHIELD WASHER REPAIR KIT

1973-78 Ser 10-30, Blazer
F7081-10150-RK each14.95



WINDSHIELD WASHER PUMP

(w/o recessed blades)
1970 10-30 Ser
1971-72 All, 10-30 Ser, Blazer
F7374-10153-A each39.95



WINDSHIELD WASHER BOTTLE, GLASS

1962-69 all g.m. and 1970 nova glass triangle washer fluid bottle with s/s Bracket and bottle cap.
A6469-10154-A set.44.95



WINDSHIELD WIPER RESERVOIR

Includes reservoir, lid, hose, and filter.
1967-72 Pickup
F6769-10154-A each9.95
1976-78 Ser 10-30, Blazer, Jimmy
1979-84 Ser 10-30
F70-10154-A each28.95



WASHER JAR BRACKET

Black
1967-72 Pickup
F6769-10154-B each8.95



WINDSHIELD WIPER SWITCH

1967 Chevy/GMC Pickup
F6768-10163-A each36.95

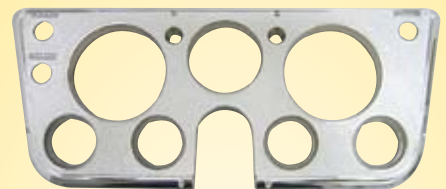

NEW INSTRUMENT BEZEL

For pickups with gauge package and no choke hole, all chrome.
1969-72 Pickup, Blazer, And Suburban
P6772-10250-JC each44.95



THREE HOLE DASH BEZEL

Black/chrome dash bezel, used with warning lights, without manual choke hole.
1969-72 Chevy/GMC Pickup, Blazer, and Suburban
P6972-10250-B3 each79.95
All chrome dash bezel, used with warning lights, without manual choke hole.
1969-72 Chevy/GMC Pickup, Blazer, And Suburban
P6972-10250-C3 each79.95





BODY MOUNTING, AIR COND., DASH PARTS



DASH CLUSTER BEZEL

The large bezel that surrounds the speedometer and gauges.

1940-46 Chevy & GMC

Chromed steel without the brown inside paint.

P4046-10250-A each52.95

1940-46 Chevy & GMC

Chromed steel with brown paint.

P4046-10250-BP each69.95



1955-59 Pickup

Chrome

P5559-10250-CH each69.95

1967-68 Chevy/GMC All

Made for use with a manual choke. Black finish with chrome trim.

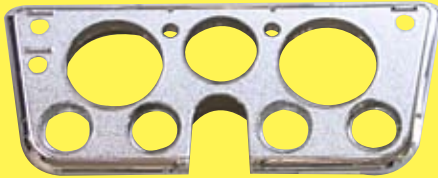

P6768-10250-BAS each79.95

1967-68 Chevy/GMC All

For vehicles with gauges and manual choke, chrome finish.

P6768-10250-CH each79.95

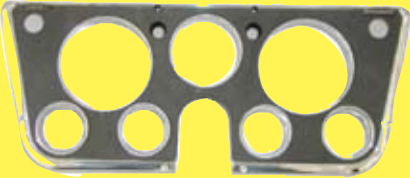

1969-72 Chevy/ GMC Pickup

Black instrument bezel with chrome trim, for pickups with gauge package and no choke hole.

P6772-10250-BAS each44.95

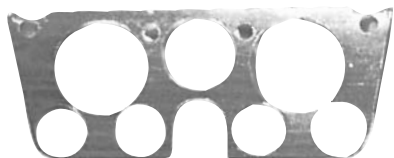

BRUSHED ALUMINUM INSTRUMENT PANEL APPLIQUE

Not a decal.

1969-72 Pickup, Blazer and Suburban

P6972-10250-ALM each21.95

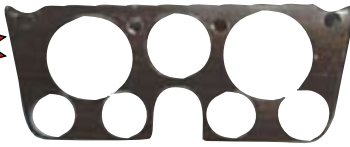

BURL WOODGRAIN INSTRUMENT PANEL APPLIQUE

1969-72 Pickup, Blazer and Suburban

P6972-10250-BUR each21.95

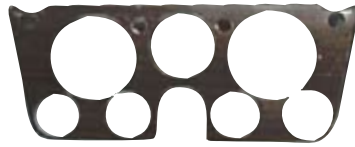

WALNUT INSTRUMENT PANEL APPLIQUE

1969-72 Pickup, Blazer and Suburban

P6972-10250-W each21.95



original black with chrome trim



all black, no trim

GMC INSTRUMENT PANEL BEZEL

1975-77 Chevy/GMC Pickup All pickups with a/c except Silverado, Sierra classic, or wood grain package.

Made as original black with chrome trim.

P7577-10250-A each169.95

1975-77 Chevy/GMC Pickup Fits all with a/c except Silverado, Sierra classic, or woodgrain insert.

All black, no trim.

P7577-10250-B each114.95

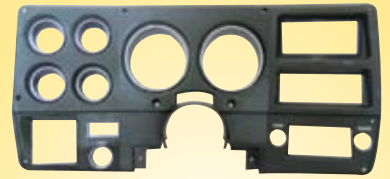

DASH BEZEL

1975-77 Chevy Pickup

With black bezel and silver on letters only.

P7577-10250-BAC each99.95

1975-77 Pickup

With black bezel and silver trim.

P7577-10250-SAC each129.95

1975-77 Chevy/GMC Pickup

Fits all with a/c except Silverado, Sierra classic, or woodgrain insert. Black with silver trim.

P7577-10250-S each129.95



LOWER STEERING COLUMN COVER

1973-77 Pickup

P7577-10250-L each24.95



DASH GAUGE ASSEMBLY

1967-68 Chevy/GMC Pickup

Complete with: bezel w/choke, speedometer, fuel, temp, amp, oil gauge, and circuit board.

P6768-10251-KIT kit449.95

1967-68 Chevy/GMC Pickup, Suburban

Complete with: bezel w/choke, fuel, speedometer, oil, amp, temp, gauge, and tachometer.

Comes ready to install w/circuit board.

P6768-10251-KITT kit499.95

1967-68 Pickup & Suburban

Complete with: tach, vacuum, speedometer, fuel, oil, temp, amp, gauge, bezel w/choke, and circuit board. Comes ready to install.

P6768-10251-KITTV kit599.95

1969-72 Chevy/GMC Pickup, Blazer, Suburban

Complete with: bezel, speedometer, fuel, temp, amp, oil gauge, and circuit board. Comes assembled and ready to install.

P6972-10251-KIT kit449.95

1969-72 Chevy/GMC Pickup, Blazer, Suburban

Complete with: tachometer, fuel, speedometer, amp, temp, oil gauge, circuit board, and black/chrome bezel. Comes ready to install.

P6972-10251-KITT kit499.95

1969-72 Chevy/GMC Pickup, Blazer, Suburban

Complete with: bezel, tach, vacuum, speedometer, fuel, amp, temp, oil gauge, and circuit board. Comes ready to install.

P6972-10251-KITTV kit599.95



BRIGHT LIGHT INDICATOR LENS AND TUNNEL ASSEMBLY

Fits behind dash backing plate. Requires 2 per truck.

1967-72 Chevy/GMC All (Green lens)

P6772-10251-G each2.95

1967-72 Chevy/GMC All (Red lens)

P6772-10251-R each2.95

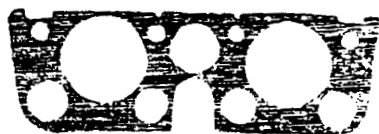

WOODGRAIN INSTRUMENT PANEL DECAL

1967 Pickup

P67-10252-BS each14.95

1967-72 Pickup

P6772-10252-AS each15.95

1968 Pickup

P68-10252-CS each14.95

1969-72 Pickup

P6972-10252-DS each14.95

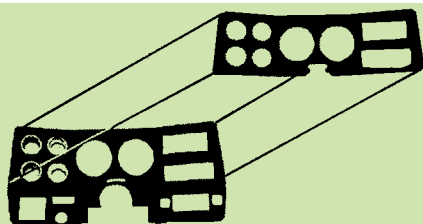

WOODGRAIN BEZEL INSERT

1975-77 Pickup

Burl, not original.

P7577-10252-B each56.95

1975-77 Pickup

Walnut, not original.

P7577-10252-W each56.95

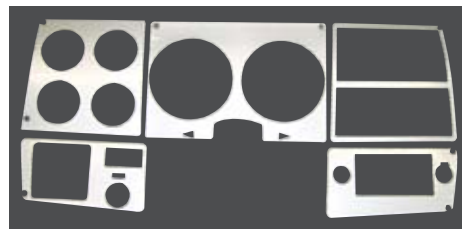

BRUSHED ALUMINUM BEZEL INSERT

Stick-on cover for repairing old bezel, (you must reuse your old bezel), 5 piece kit.

1978-80 Pickup

P7880-10252-KT kit79.95



DASH BEZEL SCREW SET

1955-59 Pickup

P5559-10253-AS set.1.95

1964-66 Pickup

P6466-10253-AS set.1.95

1967-72 Pickup

P6772-10253-AS set.4.95

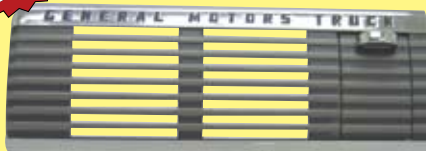

1947-53 GMC Pickup

CENTER DASH SET

Includes painted speaker grill, upper stainless molding with correct lettering, lower stainless molding, and ash tray assembly with chrome knob.

1947-53 Chevrolet Pickup

P4753-10256-CHV each109.95

1947-53 GMC Pickup

P4753-10256-GMC each109.95



RADIO WOODGRAIN

1967-72 Pickup

P6772-10256-AS each5.95

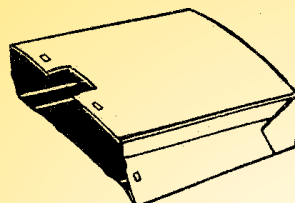

GLOVE BOX ASSEMBLY

Glove box liner

1936-39 Pickup

P3639-10260-A each14.95

1940-46 Pickup

P4046-10260-A each12.95

1947-49 Chevy Pickup

P4749-10260-A each12.95

1947-49 GMC Pickup

P4749-10260-B each12.95

1950-53 Pickup

P5053-10260-A each12.95

1954-55 Pickup (1st Series)

P54-10260-A each12.95

1954 GMC Pickup

P54-10260-GMC each12.95

1955-59 Pickup (2nd Series)

P5559-10260-A each12.95



1967-72



1973-86 w/ air

MOLDED PLASTIC GLOVE BOX

1967-72 Pickup

P6772-10260-P each46.95

1973-86 Chevy / GMC, Blazer, Suburban
Without A/C

P7386-10260-A each39.95

1973-86 Chevy, GMC, Blazer, Suburban
With factory air

P7386-10260-B each39.95

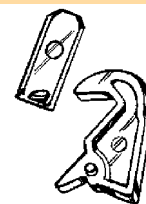

GLOVE BOX LOCK HOOK AND SLIDE

1940-53 Pickup

P4753-10261-A set.4.95



Keep that stuff contained!

1955-59 GMC Pickup

P5559-10260-GMC each12.95

1960-63 Pickup

P6063-10260-A each12.95

1960-66 GMC Pickup

P6066-10260-GMC each12.95

1964-66 Pickup (w/ out AC)

Without air conditioning only.

P6466-10260-A each12.95

1964-66 Pickup (with AC)

With air conditioning only.

P6466-10260-B each12.95

1967-72 Pickup (w/ out AC)

Without air conditioning only (fiberboard).

P6772-10260-A each12.95

1967-72 Pickup (w/ AC)

With A/C

P6772-10260-B each12.95



BODY MOUNTING, AIR COND., DASH PARTS

NEW!



1947-53 with painted accents



1947-53 unpainted

STAINLESS STEEL GLOVE BOX DOOR ASSEMBLY

1947-53 Chevy/GMC Pickup
With painted accents.

P4753-10261-P each89.95

1947-53 Chevy/GMC Pickup
Unpainted.

P4753-10261-SS each89.95



GLOVE BOX SCREW KIT

1947-54 Pickup

P4754-10260-MB kit.1.95



1964-66



1967-68



1969-70

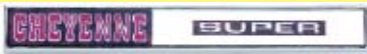

1971



1972

GLOVE BOX DOOR EMBLEM

'Chevrolet', gray w/ black letters.

1964-66 Chevy Pickup

P6466-10261-A each24.95

'Chevrolet', chrome plated.

1964-66 Chevy Pickup

P6466-10261-B each24.95

'Chevrolet'

1967-68 Chevy Pickup

P6768-10261-A each24.95

'Chevrolet Custom'

1969-70 Chevy

1969-72 Blazer

P6972-10261-A each24.95

'Chevrolet Custom'

1969-72 Chevy Pickup

P6972-10261-B each19.95

'GMC Custom'

1969-72 GMC Pickup

P6972-10261-GA each19.95

'Cheyenne Super'

1971 Chevy Pickup

P71-10261-A each64.95

'Cheyenne Super'

1972 Chevy Pickup

P72-10261-A each39.95



BRUSHED ALUMINUM GLOVE BOX APPLIQUE

Not a decal.

1967-72 All except Cheyenne super

P6772-10261-ALUM each21.95

1971-72 Cheyenne super

P7172-10261-ALUM each21.95



BURL GRAINED GLOVE BOX COVER

Not a decal.

1967-72 All except Cheyenne Super

P6772-10261-BURL each.21.95

1971-72 Cheyenne Super

P7172-10261-BURL each.21.95



WALNUT GLOVE BOX COVER

Not a decal.

1967-72 Pickup, Blazer, Suburban (exc. Cheyenne Super)

P6772-10261-WLNT each21.95

1971-72 Cheyenne Super

P7172-10261-WLNT each21.95



NEW!

GLOVE BOX DOOR ASSEMBLY

Painted black.

1967-72 Chevy/GMC Pickup

P6772-10261-B each89.95

Chrome plated.

1967-72 Chevy/GMC Pickup

P6772-10261-C each119.95

1967-72 Pickup

Chrome face complete with wood grain insert, exact replica of the Cheyenne plate.

P6772-10261-CH each69.95



GLOVE BOX DOOR BUMPERS

Lid bumper, Requires 2.

1940-84 Pickup (glove box door bumper)

1955 Pickup (2nd Series) body bumper - Req. 2

1973-77 (2wd, 4wd, Ser 10-30, Blazer, Jimmy, ash tray bumper)

P4754-10263-BM each.95



GLOVE BOX BUMPER SET

Contains correct amount of 3.

1967-72 Pickup

P6772-10263-BM set1.95

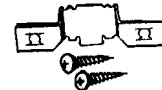

GLOVE BOX STRIKER W/SCREWS

1954-59 Pickup

P5459-10263-A each4.95

1960-66 Pickup

P6066-10263-A each4.95

1967-72 Pickup

P6772-10263-B each4.95



GLOVE BOX DOOR STOP

1967 Ser 10-30 (exc. FFC)

P67-10263-ST each1.95

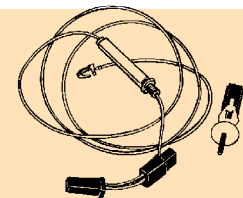

GLOVE BOX LIGHT

Complete assembly.

1967-72 Pickup

P6772-10263-A each15.95



GLOVE BOX SCREW SET

1955-59 Pickup

P5559-10264-AS set.1.95

(8 screws and 4 clips)

1967-72 Pickup

P6772-10264-AS kit2.95

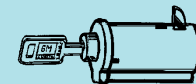

GLOVE BOX LOCK W/KEYS

1947-53 Pickup

P4753-10266-A set.29.95

1954-72 Pickup

P54-10266-A set.25.95



BODY MOUNTING, AIR COND., DASH PARTS



GLOVE BOX LOCK

Glove box lock & keys.

1967-68 Chevy/GMC (original style)

P6768-10266-AS each29.95

1967-72 Chevy/GMC (replacement style)

P6772-10266-BS each24.95

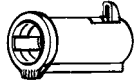

GLOVE BOX DOOR CASE ASSEMBLY

With lock bolt less cylinder, retainer & keys.

1954-72 All

P5472-10266-CA each15.95



1954-72

1973-78

GLOVE BOX LOCK CASE

1954-72 Pickup

P5559-10266-A each3.95

1973-78 Ser 10-30, Blazer, Jimmy

1979-84 Ser 10-30

F7681-10266-C each19.95

GLOVE BOX LOCK GASKET



1947-53 Pickup

P4753-10268-A each95

1954-59 Pickup

P54-10268-A each95

1960-66 Pickup

P6066-10268-LG each95

1960-72 Pickup

P6772-10268-G each95



DOOR LOCK KIT

1974-88 All

F7981-10470-K pair29.95

DOOR LOCK KNOBS, DIE CAST & CHROME PLATED



Chrome interior.

1968-81 Chevy Pass

F6881-10529-PR Pair12.95

FRONT DOOR LOCK CYLINDER RETAINER



1973-81 Ser 10-30, Blazer, Jimmy Front or Rear
1979-84 Ser 10-30

F7275-10551-A each1.95



REMOTE LOCK ROD KNOB

Door remote lock rod knob (all doors)

1965-72 Ser. 10-30 & Blazer

P6572-10559-KN each2.95



DOOR BUMPER SET

(4 pcs)

1967-72 Pickup

P6772-10587-AS set.6.95

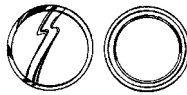

DOOR HOLE PLUG

1967-72 Pickup

P6772-10587-BS pair95



B-10606



SR-10606

VOLTAGE REDUCER

Reducer used when converting 6 volt system to 12 volt and still using 6 volt gauges. 12v down to 6v, ideal for fuel gauge.

B-10606 each4.95

NEW! No need to change gauges or senders.

Just install this electronic voltage reducer on the back of each gauge and the gauges will continue to run even though your truck is on 12 volt.

SR-10606 each4.95



DOOR WINDOW SWITCH

Front door window switch, w/escutcheon, (2 button).

1977-78 (2wd, 4wd, Ser 10-30, Blazer, Jimmy)

1979-81 (2wd, 4wd, Ser 10-30 (Cab 2 Door, Blazer, Jimmy)

F7781-10777-A each99.95



WINDOW REGULATOR ROLLER FOR DOOR WINDOW

1967-72 Pickup

A6465-10792-A each4.95



MOULDING CLIP SET

46 pcs

1955-59 Pickup

P5559-12000-CL set.27.95



DOOR & REAR WINDOW MOULDING SET

Stainless steel.

1955-59 Pickup

P5559-12000-SS set.189.95



REAR QUARTER ARM REST ASH TRAY

1973-76 Ser. 10-30, (four door) - Rear door

F67-12045-A each49.95

sample of each type of piece included



RUBBER BUMPER KITS

Includes 10 hood bumpers of different sizes, 4 door bumpers, and 2 ash tray bumpers.

1947-54 Pickup

P4754-12100-A Kit17.95

1955-59 Pickup

P5559-12100-A Kit17.95

1960-63 Pickup

P6063-12100-A Kit17.95

1964-66 Pickup

P6466-12100-A Kit17.95

1967-72 Narrow bed trucks

P6772-12100-NB Kit.17.95

1967-72 Fleetside

For wide bed trucks.

P6772-12100-WB Kit19.95

PRESSURE RELIEF PLASTIC VALVE FOR DOOR JAMB



1971-72 Pickup

A7072-12942-V each36.95



CARPET

**THE BEST
MONEY CAN BUY!**

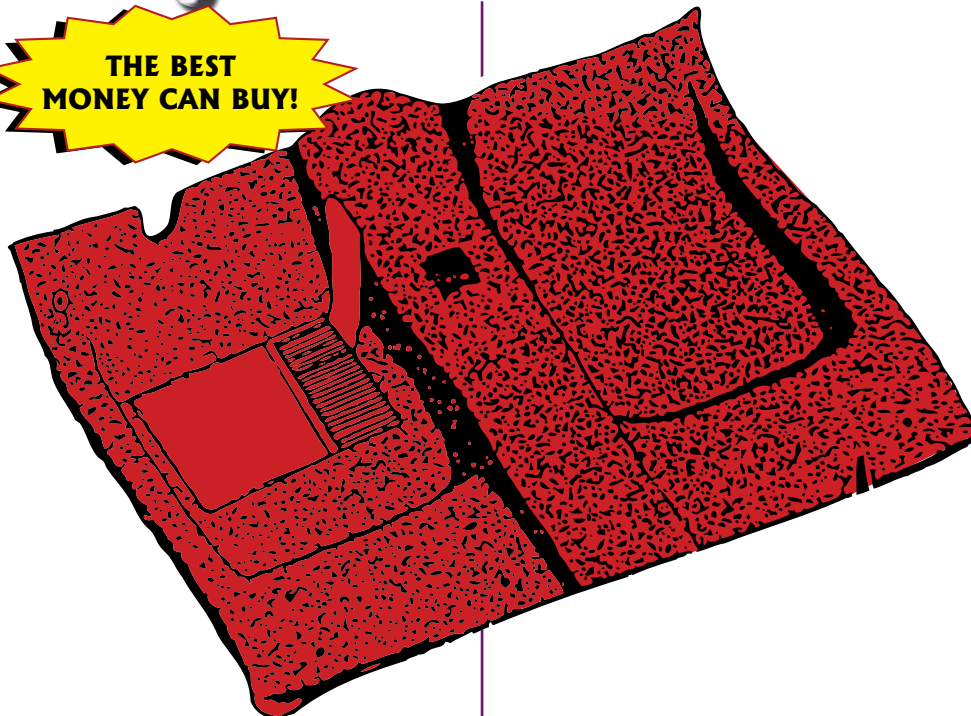

AUTHENTIC MOULDED CARPET

Our carpet is moulded to the original factory specifications. It is made of 80/20 rayon/nylon loop (the best in quality!) Listed below are the most popular colors available which should satisfy the needs of 99% of all trucks. We do want to inform you that we can special order almost any color of your choice that might not be installed. All special order items must be pre-paid. Please allow 10-12 days for delivery.

Carpet details:

- Backing Material (To offer soft, thick cushion effect for comfort as well as appearance. Optional on some sets.)
- Serged edges (Nylon thread or vinyl is used depending on the original style. Prevents fraying and separation from moulding)
- Dimmer switch cutout (Not available for some sets due to difficulty in accurate placement)
- 4 speed cutout (Where applicable)
- Contoured fit over transmission tunnel (Eliminate bulges and wrinkles)

Basic colors available:

- Red • Medium Blue • Emberglow • #13 Blue • Oxblood • Bright Blue • Maroon
- Dark Blue • Teal • Black • Moss Green • Ivy Gold • Silver • Dark Brown • Gold
- Dark Saddle • Light Saddle • Aqua • Sandlewood

When ordering you MUST include the following information:

1. Year
2. Automatic or standard transmission
3. 2WD or 4WD
4. Column or floor shift
5. Bench or bucket seats
6. Console?
7. Color

**Please read
THOROUGHLY
prior to ordering!**

COMPLETE CARPET SETS

Includes passenger section, cargo area, wheel wells.

1947-54 Pickup

Early Pickup carpet set. Comes in black, red, dark blue, med blue, dark saddle & gun metal grey. 80/20 loop.

CARP-13000-ESPO set 139.95

1955-80 Pickup/GMC

Special order.

CARP-13000-PSPO each 139.95

1967-72 Suburban

Complete molded carpet set, front & rear passenger area and cargo area. Special order

Oversize shipping

CARP-13000-SUBSPO each 399.95

1969-72 Blazer

1973-77 Blazer (80/20 or cut pile)

1978-80 Blazer (cut pile)

(Front and cargo area carpet)

CARP-13000-BCSPO set 299.95

1969-80 Blazer (Front area carpet only)

CARP-13000-BPSPO each 139.95

1969-80 Blazer, Jimmy (cargo area w/

wheel wells)

CARP-13000-CJSPO each 139.95

1969-80 Jimmy

CARP-13000-JPSPO each 139.95

CARPET BY LINEAR YARD

72" wide x 36" long. (80/20, cut pile, nylon loop)

CARP-13000-SQY per yard 39.95

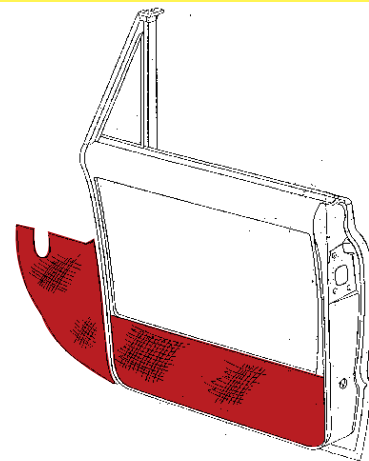

DOOR & KICK PANEL CARPET

(80/20 loop) Lower door, kick panel and gas tank cover carpet set. These are upholstered pieces made to cover your lower doors and kick panels. They are made in carpet colors to match the original interior colors of your truck. (These are a must for everyone wanting that finished look!)

1967-72 Pickup (Black)

P6772-13000-BLK set 159.95

1967-72 Pickup (Medium Blue)

P6772-13000-BLU set 159.95

1967-72 Pickup (Dark Green)

P6772-13000-GR set 159.95

1967-72 Pickup (Red)

P6772-13000-RD set 159.95

1967-72 Pickup (Dark Saddle)

P6772-13000-SD set 159.95



CUSTOM EMBROIDERED FLOOR MATS

These mats are made to be installed on top of the carpet stock with the same care and attention to detail as our moulded carpet sets. The bottoms are made of durable, pliable synthetic material that has ribs formed in it to grip the main carpet set to eliminate slipping. We have a wide variety of embroidered logos available. All sets are sold in stock 2 piece sets. Some are available in 4 piece sets for Extended Cab Pickups, Blazers & Suburbans. Please note these are special order and must be paid for in advance. Allow 10-14 days for delivery.

Listed below are available mat colors in 80/20 rayon nylon loop just like the original carpet sets. There are two colors listed: 1st color being the carpet and the 2nd color being the emblem.

Colors available:

- Black/ Red
- Emberglow/ Ivy Gold
- Dark Green/ Medium Blue
- Aqua/ Dark Blue
- Dark Brown/ Light Saddle
- Dark Saddle/ Maroon
- Moss Green/ Teal
- Silver/ Sandlwood
- Gold/ Baby Blue
- #13 Blue/ Bright Blue

**Please
read
before
ordering!**

If you are unsure of your carpet color, please send us a clean 3 x 3" sample and we will match it for you!

When ordering you MUST include the following information:

1. Year of Pickup
2. Make and model of Pickup
3. Automatic or standard transmission
4. 3 or 4 speed etc.
5. Column or floor shift
6. 2 WD or 4 WD
7. Bench or bucket seats
8. Color
9. Embroider design base color

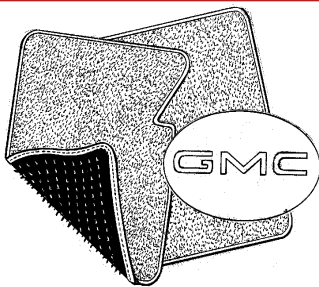

GMC EMBROIDERED FLOOR MAT

2 piece set.
FMAT-13000-ASPO68 set 74.95
 4 piece set.
FMAT-13000-BSP068 set 69.95

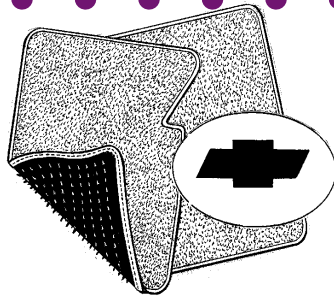

BOWTIE EMBLEM EMBROIDERED FLOOR MATS

2 piece set.
 1947-72 Chevy Pickup
FMAT-13000-ASPO11 pair 74.95



HEARTBEAT USA EMBROIDERED FLOOR MAT

2 piece set.
FMAT-13000-ASPO65 set 99.95
 4 piece set.
FMAT-13000-BSP065 set 109.95



HEARTBEAT OF AMERICA, YESTERDAY'S CHEVROLET EMBROIDERED FLOOR MAT

2 piece floor set.
FMAT-13000-ASPO67 set 99.95

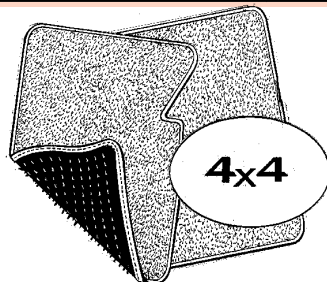

4 X 4' EMBROIDERED FLOOR

2 piece set.
FMAT-13000-ASPO82 set 74.95
 4 piece set.
FMAT-13000-BSP082 set 69.95



FLOOR MAT FELT INSULATION PAD

Cut to fit for earlier years.
 1960-72 Pickup (36" x 70")
P6072-16800-IP each 12.95

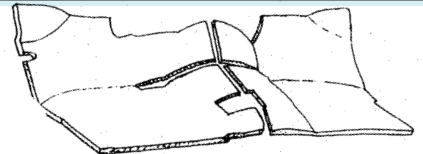

SOUND DEADENER SET

O.E. type sound deadener material. Pre-cut to fit your truck.
 1947-54 Pickup
P4754-13000-A each 44.95
 1955-59 Pickup
P5559-13000-A each 39.95
 1960-66 Pickup
P6066-13000-A each 39.95
 1967-72 Pickup (for small hump)
P6772-13000-A set 39.95
 1967-72 Pickup (for large hump)
P6772-13000-B set 44.95
 1973-80 Pickup
P7380-13000-A each 39.95

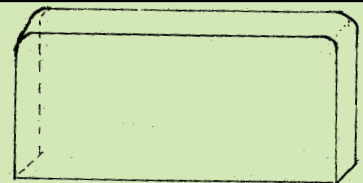

GAS TANK COVER

Original material, rolled into it's own box and is pre-punched for staples which are included for assembly.
 1960-66 Pickup
P6066-13000-OEM each 24.95
 1967-72 Pickup
P6772-13000-OEM each 24.95

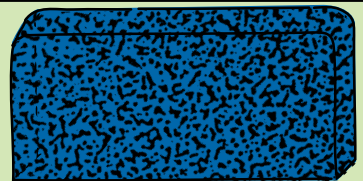

GAS TANK COVER CARPET

80/20 loop, like original.
 1970-72 Pickup (Black)
P7072-13000-BLK each 84.95
 1970-72 Pickup (Blue)
P7072-13000-BLU each 89.95
 1970-72 Pickup (Dark Green)
P7072-13000-GR each 89.95
 1970-72 Pickup (Red)
P7072-13000-RD each 89.95
 1970-72 Pickup (Dark Saddle)
P7072-13000-SD each 89.95

**We appreciate
your business!**



LICENSE PLATE BACK

Polished louvered stainless steel. Finishes off the back where tag is openly exposed.

B-13409-LSS each9.95



"NOTHING WORKS LIKE A CHEVY TRUCK" LICENSE PLATE

Chevy Truck

LP-13409-TRK each6.95



CHEVROLET CROSS FLAG LICENSE PLATE

LP-13409-9 each6.95



GMC TRUCK MOTORSPORT

White

LP-13409-GMW each9.95



USA #1 TODAY'S CHEVROLET

Black

LP-13409-USAB each7.95



"HEARTBEAT OF AMERICA, YESTERDAYS CHEVY TRUCK" LICENSE PLATE

Black w/ white and red letters.
Chevy Truck

LP-13409-YCT each6.95



LP-13409-19



LP-13409-5



LP-13409-26



LP-13409-6

EMBOSSED LICENSE PLATES

"Chevrolet truck"

LP-13409-19 each6.95

"Chevrolet bow-tie"

LP-13409-5 each6.95

"The Heartbeat of America"

LP-13409-26 each6.95

"Chevrolet USA #1"

LP-13409-6 each7.95



LICENSE PLATE FRAME

Chrome plated w/ white letters on blue background.

1932 Pickup **P32-13409 each5.95**

1933 Pickup **P33-13409 each5.95**

1934 Pickup **P34-134095.95**

1935 Pickup **P35-13409 each5.95**

1936 Pickup **P36-13409 each5.95**

1937 Pickup **P37-13409 each5.95**

1938 Pickup **P38-13409 each5.95**

1939 Pickup **P39-13409 each5.95**

1940 Pickup **P40-13409 each5.95**

1941 Pickup **P41-13409 each5.95**

1942 Pickup **P42-13409 each5.95**

1946 Pickup **P46-13409 each5.95**

1947 Pickup **P47-13409 each5.95**

1948 Pickup **P48-13409 each5.95**

1949 Pickup **P49-13409 each5.95**

License plate frames cont...



1950 Pickup

P50-13409 each5.95

1951 Pickup

P51-13409 each5.95

1952 Pickup

P52-13409 each5.95

1953 Pickup

P53-13409 each5.95

1954 Pickup

P54-13409 each5.95

1955 Pickup

P55-13409 each5.95

56 Pickup

P56-13409 each5.95

1957 Pickup

P57-13409 each5.95

1958 Pickup

P58-13409 each5.95

1959 Pickup

P59-13409 each5.95

1960 Pickup

P60-13409 each5.95

1961 Pickup

P61-13409 each5.95

1962 Pickup

P62-13409 each5.95

1963 Pickup

P63-13409 each5.95

1964 Pickup

P64-13409 each5.95

1965 Pickup

P65-13409 each5.95

1966 Pickup

P66-13409 each5.95

1967 Pickup

P67-13409 each5.95

1968 Pickup

P68-13409 each5.95

1969 Pickup

P69-13409 each5.95

1970 Pickup

P70-13409 each5.95

1971 Pickup

P71-13409 each5.95

1972 Pickup

P72-13409 each5.95

1973 Pickup

P73-13409 each5.95

1974 Pickup

P74-13409 each5.95

1975 Pickup

P75-13409 each5.95

1976 Pickup

P76-13409 each5.95

1977 Pickup

P77-13409 each5.95

1978 Pickup

P78-13409 each5.95

1979 Pickup

P79-13409 each5.95

KICK PANELS & HEADLINER PARTS

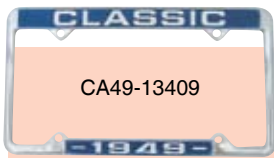

CA49-13409

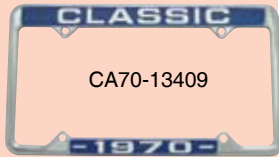

CA70-13409

CLASSIC LICENSE PLATE FRAME

1949 All	
CA49-13409 each	5.95
1950 All	
CA50-13409 each	5.95
1951 All	
CA51-13409 each	5.95
1952 All	
CA52-13409 each	5.95
1953 All	
CA53-13409 each	5.95
1954 All	
CA54-13409 each	5.95
1955 All	
CA55-13409 each	5.95
1956 All	
CA56-13409 each	5.95
1957 All	
CA57-13409 each	5.95
1958 All	
CA58-13409 each	5.95
1959 All	
CA59-13409 each	5.95
1960 All	
CA60-13409 each	5.95
1961 All	
CA61-13409 each	5.95
1962 All	
CA62-13409 each	5.95
1963 All	
CA63-13409 each	5.95
1964 All	
CA64-13409 each	5.95
1965 All	
CA65-13409 each	5.95
1966 All	
CA66-13409 each	5.95
1967 All	
CA67-13409 each	5.95
1968 All	
CA68-13409 each	5.95
1969 All	
CA69-13409 each	5.95
1970 All	
CA70-13409 each	5.95
1971 All	
CA71-13409 each	5.95
1972 All	
CA72-13409 each	5.95



WIRING FRAME CLAMP

Pkg. of 10	
B-14585-K each	2.95

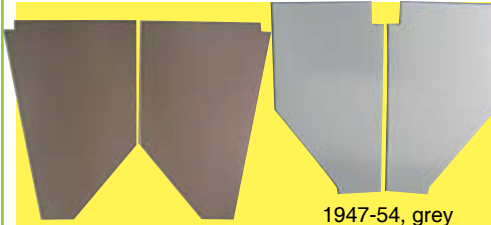

1941-46, brown

1947-54, grey

COWL KICK PANELS

Hand cut cardboard.	
1936-40 Pickup (Black)	
P3640-14630-BLK pair	14.95
1936-40 Pickup (Brown)	
P3640-14630-BRN pair	14.95
1936-40 Pickup (Gray)	
P3640-14630-GRY pair	14.95
1936-40 Pickup (Pearl Beige)	
P3640-14630-PB pair	14.95
1941-46 Pickup (Brown)	
P3946-14630-A pair	14.95
1941-46 Pickup (Black)	
P3946-14630-B pair	14.95
1941-46 Pickup (Grey)	
P3946-14630-GRY pair	14.95
1947-54 Pickup (Black)	
P4754-14630-BLK pair	14.95
1947-54 Pickup (Brown)	
P4754-14630-BRN pair	14.95
1947-54 Pickup (Grey)	
P4754-14630-GRY pair	14.95

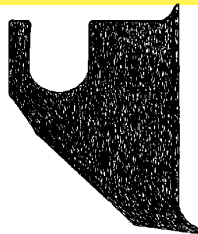

ABS PLASTIC INTERIOR KICK PANELS

May be painted to match.	
1960-66 Pickup, Panel, Suburban (Black)	
P6066-14630-BL pair	46.95
1967-72 Pickup (Black)	
P6772-14630-BL pair	46.95



P7587-14630-LWAC P7587-14630-LWOAC

KICK PANEL

Full cover plastic kick panel. Black, paint to match.	
1975-87 Chevy Pickup (Black, left hand)	
P7587-14630-LWAC each	29.95
1975-87 Chevy Pickup (Black, W/out ac, left hand)	
P7587-14630-LWOAC each	39.95
1975-87 Chevy Pickup (Black, Right hand)	
P7587-14630-RH each	36.95

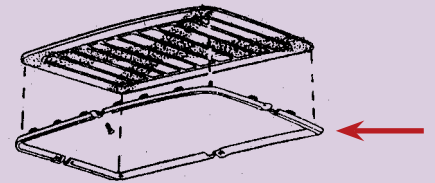

CHROME HEADLINER TRIM KIT

4pc. kit w/ hardware and instructions.	
1967-72 Pickup	
P6772-14640-CHT kit	99.95

Classic Chevrolet Parts Inc.

8723 S. I-35
Oklahoma City, OK 73149

Summer Store Hours:

Monday — Friday
8 a.m. thru 6 p.m.

Saturday
8 a.m. thru 12 p.m.

Winter Store Hours:

Monday — Friday
8 a.m. thru 5 p.m.

Saturday
8 a.m. thru 12 p.m.

(Central Standard Time)

Stop by our showroom!





KICK PANELS & HEADLINER PARTS

Headliners continued

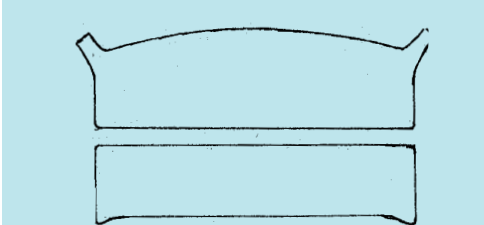

HEADLINERS

Forming with ammonia and water may be necessary.

- 1937-38 Pickup (Black)
P3738-14640-BLK each 44.95
- 1937-38 Pickup (Brown)
P3738-14640-BRN each 49.95
- 1937-38 Pickup (Gray)
P3738-14640-GRY each 49.95
- 1939-41 Pickup (Black)
P3941-14640-BLK each 44.95
- 1939-41 Pickup (Gray)
P3941-14640-GRY each 49.95
- 1942-46 Pickup (Black)
P4246-14640-BLK each 29.95
- 1942-46 Pickup (Brown)
P4246-14640-BRN each 29.95
- 1942-46 Pickup (Gray)
P4246-14640-GRY each 29.95
- 1942-46 Pickup (Pearl Beige)
P4246-14640-PB each 29.95

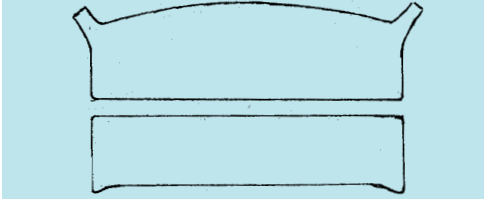

- 1947-49 Pickup, Black (Dye Stamped Headliners)
P4749-14640-BLK each 26.95
- 1947-49 Pickup (Brown)
P4749-14640-BRN each 26.95
- 1947-49 Pickup (Gray)
P4749-14640-GRY each 29.95
- 1947-49 Pickup (Pearl Beige)
P4749-14640-PB each 29.95
- 1949-53 Pickup (Pearl Beige)
P4953-14640-PB each 29.95
- 1949-53 Late Pickup (Black)
P5053-14640-BLK each 26.95
- 1949-53 Late Pickup (Brown)
P5053-14640-BRN each 26.95
- 1949-53 Late Pickup (Grey)
P5053-14640-GRY each 26.95
- 1954-55 Pickup (Black)
P54-14640-BLK each 26.95
- 1954-55 Pickup (Brown)
P54-14640-BRN each 26.95
- 1954-55 Pickup 1st Series (Grey)
P54-14640-GRY each 26.95
- 1954-55 Pickup w/ deluxe cab interior (light Blue)
P5455-14640-LB set 69.95
- 1954-55 Pickup w/dlx cab interior (light metal. Green)
P5455-14640-LMG set 69.95
- 1954-55 Pickup (Pearl Beige)
P5455-14640-PB set 29.95

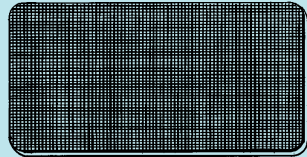

- 1955-59 Pickup (Black)
P5559-14640-BI each 49.95
- 1955-59 Pickup (Cream)
P5559-14640-CI each 49.95

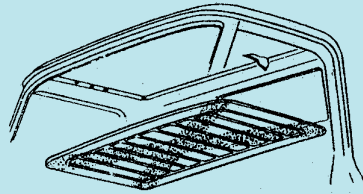

- 1967-72 Chevy/GMC Pickup (Black pleated vinyl)
P6972-14640-BLK each 129.95
- 1967-72 Chevy/GMC Pickup (Dark blue, original style)
P6972-14640-DB each 129.95
- 1967-72 Chevy/GMC (Dark green pleated)
P6972-14640-DGR each 129.95
- 1969-72 Chevy/GMC Pickup (Saddle)
P6972-14640-SD each 129.95
- 1967-72 Chevy/GMC Pickup (White pleated vinyl)
P6972-14640-TN each 129.95



HEADLINER SCREW KIT

- (11 items)
- 1947-55 Pickup
P4755-14640-MB set 2.95
- 1969-72 Pickup
P6972-14640-SC set 2.95



HEADLINER CENTER RETAINER BAR

- Fits between front and rear section.
- 1949-54 Pickup
P4954-14640-RT each 29.95



HEADLINER RETAINER SEAL

- Fits around edge of headliner.
- 1955-59 Pickup (Black)
P5559-14650-A each 19.95
- 1955-59 Pickup (White)
P5559-14650-B each 24.95
- 1955-59 Pickup (Red)
P5559-14650-C each 39.95



ABS VACUUM FORMED HEADLINER

Shell with pre-covered original style cloth. Easy to install, complete with instructions.

Oversize, additional shipping

- 1973-87 Chevrolet Pickup
- (Black) **P7387-14640-BLK each . . . 159.95**
- (Saddle) **P7387-14640-SD each . . . 159.95**
- (Blue) **P7387-14640-BLU each . . . 159.95**
- (Buckskin) **P7387-14640-BS each . . . 159.95**
- (Charcoal) **P7387-14640-CHAR each . 159.95**
- (Md.Green) **P7387-14640-GRN each . . 159.95**
- (Lt.Gray) **P7387-14640-GRY each . . . 159.95**
- (Red) **P7387-14640-RD each . . . 159.95**

ABS VACUUM FORMED HEADLINER

Shell covered with foam back original style cloth. Easy to install, includes instructions.

1988-98 Chevrolet Pickup

- (Dk.Red) **P8898-14640-RD each . . . 159.95**
- (Lt.Saddle) **P8898-14640-LS each . . . 159.95**
- (Dk.Saddle) **P8898-14640-DS each . . . 159.95**
- (Dk.Gray) **P8898-14640-DG each . . . 159.95**
- (Navy) **P8898-14640-NB each 159.95**
- (Md.Blue) **P8898-14640-MB each 159.95**
- (Lt.Gray) **P8898-14640-LG each 159.95**
- (Dk.Beige) **P8898-14640-BG each 159.95**



HEADLINER RETAINER BAR SCREW KIT

- 1947-54 Pickup
P4754-14651-MB kit 2.95

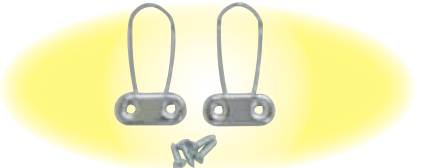

SHOULDER HARNESS RETAINER

- Holds seat belts to roof panel.
- 1964-72 Chevy Pickup
A6472-14875-A Pair 5.95



FRONT SEAT BELT SHOULDER STRAP STORAGE COVER

- 1973-75 (2wd, 4wd, Ser. 10-30, Blazer, Jimmy)
F6970-14875-C each 4.95

DOORS, MIRRORS, WINDSHIELD, INTERIOR PARTS

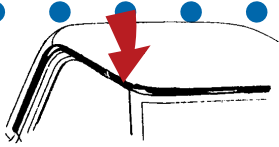

DRIP RAIL MOULDING

Stainless steel moulding set, (goes all the way around the edge of your windshield & doors).
1967-72 Pickup

P6772-16000-DR set179.95

Years 1954-80
are truckline
shipping only



WINDSHIELD GLASS

1932 Pickup Ser. 10 (flat, clear)

P32-16005-A each149.95

1933 Pickup (flat, clear)

P33-16005-A each149.95

1934 Pickup (1/2 Ton to 1-1/2 ton) (flat, clear)

P34-16005-A each149.95

1935 Pickup (flat, clear)

P35-16005-A each149.95

1936 Pickup/Panel (*1st ser.* high roof, sharp corners 14" x 46", one piece flat glass.)

P36-16005-A each149.95

1936 Pickup/Panel (2nd ser.)

Low roof, peanut shaped 14" x 46", 1 piece glass.

P36-16005-B each149.95

1937 Pickup (flat, clear)

P37-16005-A each149.95

1938 Pickup (flat, clear)

P38-16005-A each149.95

1939 Pickup (flat, clear), 2 pieces

P39-16005-A pair199.95

1940 Pickup (flat, clear)

P40-16005-A pair199.95

1941 Pickup (flat, clear)

P41-16005-A pair199.95

1942-46 Pickup (flat, clear)

P4246-16005-A pair199.95

1947-53 Chevy/GMC Pickup (flat) clear does one truck

P4750-16005-A pair199.95

1954-55 Chevy Pickup

P5455-16005-ASPO each299.95

1955-59 Chevy Pickup (specify shaded or clear)

P5559-16005-ASPO each349.95

1960-63 Pickup

P6063-16005-ASPO each599.95

1964-66 Chevy/GMC

P6466-16005-A each359.95

1967-72 Chevy/GMC (shaded)

P6772-16005-A each199.95

1973-74 Pickup

P7374-16005-A each179.95

1973-78 Ser. 10-30, Blazer, Jimmy (Tinted)

1979-84 Ser. 10-30 (Tinted)

P7384-16005-B each279.95

1973-78 (2wd, 4wd, C, K-1, 2, 3, Blazer, Jimmy)

1979-84 (2wd, 4wd, C, K-1, 2, 3)

(Clear with antenna)

P7384-16005-C each319.95

1975-80 Chevy Pickup

P7580-16005-A each179.95



1 PIECE WINDSHIELD

Eliminates the center post.

1947-53 Chevy/GMC Pickup

Clear with shaded top.

P4753-16005-CS each349.95

1947-53 Chevy/GMC Pickup

Green with shaded top.

P4753-16005-GS each349.95



WINDSHIELD GLASS DIVISION BAR

Fits between the 2 pieces of the windshield.

1939-46 Pickup

P3946-16017-A each89.95

1947-53 Pickup

P4753-16017-A each34.95



1955-59 PICKUP DASH GARNISH MOULDING

Painted black, includes installation clips.

1955-59 Pickup

P5559-16018-A each159.95



DASH MOULDING STRIP CLIP SET

1955-59 Pickup

P5559-16018-CLS 8 piece set6.95



WINDSHIELD MOUNTING SCREW SET

1947-53 Pickup

P4753-16020-MB set4.95

1954 Pickup

P54-16020-MB kit.....2.95



WINDSHIELD FRAME TO BODY BUMPERS

1936-46 Chevy/GMC Pickup

P3646-16040-BM pair.....6.95

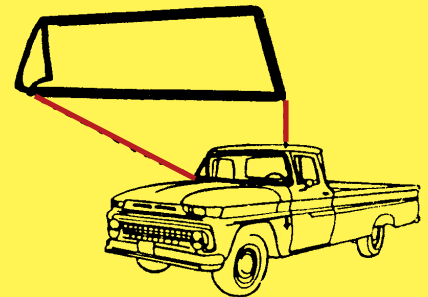

WINDSHIELD RUBBER MOULDING

Standard pickup indicates that there was not an exterior chrome molding on the windshield of your truck. Deluxe pickup indicates that there is an exterior chrome molding around the windshield of your truck thus requiring an additional groove in the gasket.

1936-46 Pickup

PU3646-16040-A each24.95

1947-53 Pickup (Standard - no groove)

PU4753-16040-A each39.95

1947-53 (Deluxe - w/ groove)

PU4753-16040-B each39.95

1954-55 (Standard - no groove)

PU5455-16040-A each39.95

1954-55 (Deluxe - w/ groove)

PU5455-16040-B each26.99

1955 (2nd Series) Thru 59 (Standard - no groove)

PU5559-16040-A each39.95

1955 (2nd Series) thru 59 (Deluxe- w/ groove)

PU5559-16040-B each39.95

1960-63 (Standard - no groove)

PU6063-16040-A each39.95

1960-63 (Deluxe - w/ groove)

PU6063-16040-B each39.95

1964-66 (Standard - no groove)

PU6466-16040-A each39.95

1964-66 (Deluxe - w/ groove)

PU6466-16040-B each39.95

1967-70 (Deluxe - w/ groove)

PU6770-16040-B each39.95

72 (Standard - no groove)

PU6772-16040-A each39.95

1971-72 (Deluxe - w/ groove)

PU7172-16040-A each49.95

1973-91 (Standard - no groove)

PU7391-16040-A each49.95

1973-91 (Deluxe- w/ groove)

PU7391-16040-B each49.95



DOORS, MIRRORS, WINDSHIELD, INTERIOR PARTS

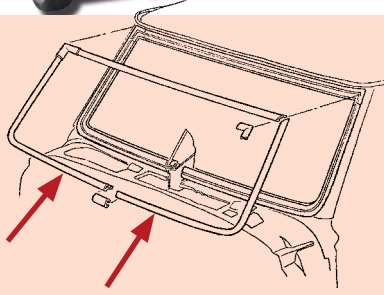

STAINLESS STEEL EXTERIOR WINDSHIELD TRIM SET

1947-53 Chevy/GMC Deluxe cab Pickup
Fits in rubber gasket.

P4753-16041-set**89.95**

1955-59 Chevy

For the deluxe windshield. Includes 4 pieces and 4 clips.

P5559-16041-set**159.95**

1967-70 Chevy/GMC

P6770-16041-S set**59.95**

1971-72 Chevy/GMC

P7172-16041-S set**64.95**



WINDSHIELD LOCKING BEAD

1973-91 All (Chrome)

PU7391-16041-A each**24.95**

1973-91 Pickup (Black)

PU7391-16041-B each**6.95**



WINDSHIELD CRANK

1939-46 Chevy GMC Pickup

P3947-16050-A each**34.95**



1947-53

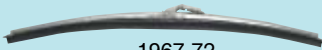

1967-72

WINDSHIELD WIPER BLADE

1929-46 Pickup (8" flat type)

P2946-16062-A each**4.95**

1947-53 Pickup (original type)

P4753-16062-A each**7.95**

1947-53 Pickup (10" new style wiper blade)

Uses spring instead of squeegee, like original.

P4753-16062-NS each**19.95**

1954-59 Pickup (original style)

P5455-16062-A each**14.95**

1955 2nd thru 59 Pickup (12" long, correct for these years)

P5559-16062-A each**19.95**

1960-66 Pickup

P6066-16062-A each**14.95**

1967-72 All (14-7/8" long)

P6772-16062-A each**19.95**



WIPER BLADE REFILL

Rubber insert (14-7/8" long)

1967-72 All

P6772-16062-IN each**12.95**

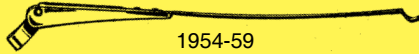

1954-59

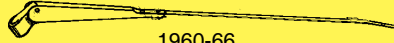

1960-66

WINDSHIELD WIPER ARM

1939-46 Pickup

(Chrome plated) Fits either side - exact as original.

P3946-16063-A each**22.95**

1947-53 Pickup

(Left hand, polished stainless steel)

Original type arms that accept the squeegee type wiper blades as original.

P4753-16063-AL each**15.95**

1947-53 Pickup

(Right hand, polished stainless steel)

Original type arms that accept the squeegee type wiper blades as original.

P4753-16063-AR each**15.95**

1947-53 Pickup (Left hand, new style wiper arm)
New style arms are used when using spring type wiper blades.

P4753-16063-NL each**15.95**

1947-53 Pickup

(Right hand, new style wiper arm)

New style arms are used when using spring type wiper blades.

P4753-16063-NR each**15.95**

1954-59 Pickup (Left hand, windshield wiper arm, polished stainless steel)

P5459-16063-AL each**15.95**

1954-59 Pickup (Right hand, windshield wiper arm, polished stainless steel)

P5459-16063-AR each**15.95**

1960-66 Pickup (Left hand, windshield wiper arm, polished stainless steel)

P6066-16063-AL each**15.95**

1960-66 Pickup (Right hand, windshield wiper arm, polished stainless steel)

P6066-16063-AR each**15.95**

1967-72 Pickup (Fits either side)

P6772-16063-A each**19.95**

1979-80 Ser 10-30 (Fits either side)

P7980-16063-A each**54.95**



CHROME WIPER BEZEL

1936-38 Pickup

P3638-16065-CWB each**19.95**



WINDSHIELD WIPER CHECK VALVE TEE

1946-72 All

P4672-16065-BCVT each**10.95**



WINDSHIELD WIPER TRANSMISSION ARM GROMMETS

Rubber

1947-54 Pickup

P4754-16065-GR pair**1.95**



WINDSHIELD WIPER TRANSMISSION ARM RETAINER

Clip and spring assembly.

1947-54 Pickup (1 7/8 center to center)

P4754-16065-TAR each**2.95**

1954-59 Pickup (2 1/4 center to center)

P5557-16065-WTC each**2.95**



STAINLESS STEEL ELECTRIC WIPER MOTOR KIT

Comes complete w/arm & blade, ideal for street rods. Aftermarket replacement.

1932-36 (6 volt)

B-16065-SS6 kit**39.95**

1932-36 (12 Volt)

B-16065-SSK each**39.95**



6 VOLT ELECTRIC WIPER MOTOR CONVERSION KIT

Replaces original vacuum motors. Complete with switch and wiring.

1947-53 Chevy Pickup

P4753-16065-6V kit**199.95**

1954-55 Pickup

P5455-16065-6V kit**199.95**



WINDSHIELD WIPER MOTOR CONVERSION KIT

Replaces original vacuum unit, 6 or 12 volt.

1954-55 Pickup

P5455-16065-CK kit**239.95**



HEAVY DUTY 12V ELECTRIC WINDSHIELD WIPER MOTOR

1932-72 Pickup (Rebuilt wiper motor)
Complete w/ 2 arms & blades, transmission arms,
2 speed switch, wiring, and mounting hardware.

P6472-16065-A each124.95

1939-46 Chevy/GMC Pickup (12-volt)
Complete with 2 arms and blades, transmission
arms, 2 speed switch, wiring, and mounting
hardware.

P3946-16065-12V kit329.95

Comes with 12 volt motor & switch only
1947-53 Chevy/GMC Pickup (12-volt)

P4753-16065-12V each199.95

1954-55 Pickup (Chevy only) (12-volt)

P5455-16065-12V each199.95

1955-57 Chevy/GMC Pickup (12-volt)

P5557-16065-12V each199.95

1958-59 Chevy Pickup (New, 12-volt)

P5859-16065-12V each199.95

1973-77 Chevy/GMC

P7377-16065-A each199.95

1978-79 Chevy/GMC

P7879-16065-A each199.95

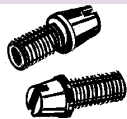

WIPER SQUIRT NOZZLE

Chrome
1955-59 Pickup

P5559-16065-WSN pair5.95

1973-78 Ser 10-30, Blazer, Jimmy

1979-80 Ser 10-30

P7380-16065-A each4.95



WINDSHIELD WASHER JAR HOSE FILTER

1960-78 All, Blazer, Jimmy
1979-84 Ser 10-30

P6072-16065-F each2.95



WINDSHIELD WASHER PUMP TO NOZZLE HOSE GROMMET

1960-72 All

P6072-16065-G each4.95



WINDSHIELD WASHER CAP

1962-72 All & Blazer

1973-84 All

P6272-16065-BC each3.95

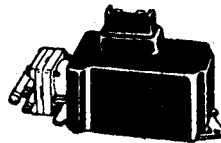

WINDSHIELD WASHER PUMP

1964-83 Chevy/GMC

P6472-16065-BP each39.95



WASHER JAR CONTAINER

1973-75 Ser 10-30, Blazer, Jimmy

P7375-16065-A each15.95

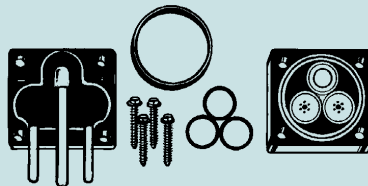

WINDSHIELD WASHER PUMP REPAIR KIT

Universal

1964-83 Chevy/GMC

P6483-16065-RK kit12.95



WIPER OUTER SPACER GASKET

1936-38 Pickup

P3638-16067-SG each95

1939-46 Pickup

P3946-16067-SG each95

1947-53 Pickup

P4753-16067-G pair1.95

1954 Pickup

P54-16067-G pair2.95



1947-53



1954-55



1955-59



1960-63



1964-66



1968-72

WINDSHIELD WIPER KNOB

1947-53 Pickup (Chrome)

P4753-16067-A each8.95

1950-53 Pickup (Maroon)

P5053-16067-A each7.95

1954-55 Pickup 1st Series (Black)

P54-16067-A each9.95

1954-55 GMC Pickup (Grey)

P54-16067-B each7.95

1955-59 Pickup (chrome plated, 9/16" hole)

P5559-16067-DK each9.95

1960-63 Pickup (reproduction, black & stainless
steel combo)

P6063-16067-A each9.95

1964-66 Pickup (black & stainless steel)

P6466-16067-A each7.95

1968-72 Ser 10-30 w/ custom sport package
(req. 1)

P6872-16067-KN each6.95



WIPER CONTROL MOUNTING GASKET

1947-53 Pickup

P4753-16067-MG each95

1954-55 (1st Series) Pickup

P54-16067-MG each95



WIPER TRANSMISSION OUTER SPACER

Chrome.

1947-53 Pickup

P4753-16067-OS pair9.95

1954-59 Pickup

P54-16067-OS pair9.95

1955-59 Pickup

P5559-16067-OS pair19.95



WIPER CONTROL LINK GROMMETS

1947-54 Pickup

P4754-16067-G pair95



DOORS, MIRRORS, WINDSHIELD, INTERIOR PARTS

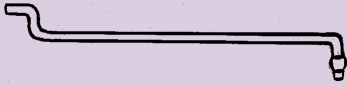

WIPER CONTROL LINK

Fits between knob and motor.
1947-54 Pickup

P4754-16067-WCL each 3.95



WIPER OUTER SPACER NUT

Stainless steel
1947-59 Pickup

P4759-16067-N each 2.95



WIPER OUTER SPACER GASKET

1955-59 Pickup

P5559-16067-AS pair 1.95

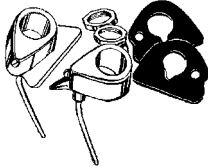

WINDSHIELD WIPER ESCUTCHEON KIT

Includes pair of escutcheons, pair of washer hole screws, pair of gaskets, & pair of lock nuts.
1955-59 Chevy Pickup

P5559-16067-K kit 24.95



1960-63

1968-72

WINDSHIELD WIPER SWITCH

1960-63 Chevy/GMC Pickup (Original style)

P6063-16067-S each 37.95

1968-72 Pickup

P6872-16067-A each 37.95

1973-74 Chevy/GMC

P7374-16067-A each 56.95

1975-77 Chevy/GMC

P7577-16067-A each 74.95

1978-83 (2wd, 4wd, (Ser w/ out pulse wipers)

P7883-16067-A each 29.95

1978-83 (2wd, 4wd, (Ser w/ Pulse wipers)

P7883-16067-B each 49.95

check us out at
www.classicchevroletparts.com



DAY/NIGHT INSIDE REARVIEW MIRROR

1947-53 Pickup (Chrome)

P4753-16068-IRM each 59.95

1954-59 Pickup (Chrome)

P5459-16068-IRM each 59.95

1957-66 Pickup (Stainless steel)

P5766-16068-IRM each 59.95

1965-70 Pickup (Stainless steel back & gray vinyl trim, 10")

P6771-16068-IRM each 44.95

1972-87 Pickup (Stainless steel)

P7287-16068-IRM each 59.95



INSIDE MIRROR

Stainless steel.
1947-59 Pickup

P4754-16068-CIM each 23.95

1960-66 Pickup

P6066-16068-CIM each 24.95

5" ROUND MIRROR HEAD

Chrome, smooth
1955-70 Truck

P5570-16068-C each 12.95



1947-70



1947-54

MIRROR HEAD

5" round

1947-54 Pickup (chrome, ribbed)

P4754-16068-C each 11.95

1947-54 Pickup (painted black, ribbed)

P4754-16068-P each 9.95

1947-70 Pickup (round, painted black)

P5559-16068-RP each 7.95

1947-70 Pickup (5 x 8" square, stainless steel)

P5559-16068-SQ each 12.95

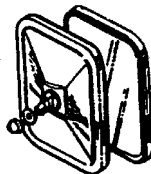

SQUARE PAINTED EXTERIOR REARVIEW MIRROR

(5" x 8") Black

1947-70 Pickup

P4770-16068-SQP each 12.95



1947-53

1954-55

1960-66

INTERIOR MIRROR BRACKET

1947-53 Pickup (Stainless steel)

P4753-16069-CMB each 7.95

1947-53 Pickup (Painted)

P4753-16069-PMB each 4.95

1954-55 Pickup (Painted)

P54-16069-PMB each 19.95

1954-55 (1st Series) (Chrome plated)

P5455-16069-CMB each 19.95

1955-59 Pickup

P5559-16069-IMB each 19.95

1960-66 Pickup (Chrome plated)

P6066-16069-CHIMB each 19.95

1969-71 Pickup (chrome, w/black cover)

P6971-16069-BIMB each 29.95

1971-72 Pickup (Left hand)

P7172-16069-BL each 14.95

1971-72 Pickup (Right hand)

P7172-16069-BR each 14.95

TRAFFIC LIGHT VIEWER

Chrome plated mounting bracket. Reproduction of early day accessory. Mounts on dash.
1947-56 Pickup

P5158-16068-TLV each 49.95



OUTSIDE MIRROR ASSEMBLY

Original style, chrome plated. Includes gasket, mounting plate & screws.

1970-72 Pickup (Left hand)

P7072-16068-LH kit 39.95

1970-72 Pickup (Right hand)

P7072-16068-RH kit 39.95



OUTSIDE MIRROR ARM

Fits on door hinge.

1936-38 Pickup (Left hand)

P3638-16069-AL each 24.95

1936-38 Pickup (Right hand)

P3638-16069-AR each 24.95

1939-46 Pickup (Left hand)

P3946-16069-AL each 24.95

1939-46 Pickup (Right hand)

P3946-16069-AR each 24.95



DOORS, MIRRORS, WINDSHIELD, INTERIOR PARTS



OUTSIDE REARVIEW MIRROR BRACKET

- 1947-50 Chevy Pickup
(Left hand, chrome plated)
- P4750-16069-CL each**29.95
- 1947-54 Chevy Pickup (Right hand)
- P4750-16069-CR each**29.95
- 1947-50 Chevy Pickup (Left hand, plain)
- P4750-16069-PL each**17.95
- 1947-50 Chevy Pickup (Right hand, black)
- P4750-16069-PR each**17.95



OUTSIDE MIRROR BRACKET

- Chrome
- 1955-59 Pickup (Left hand)
- P5559-16069-CL each**29.95
- 1955-59 Pickup (Right hand)
- P5559-16069-CR each**29.95
- Black
- 1955-59 Pickup (Left hand)
- P5559-16069-OMBL each**24.95
- 1955-59 Pickup (Right hand)
- P5559-16069-OMBR each**24.95

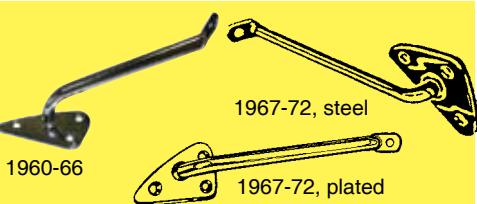

OUTSIDE REAR VIEW MIRROR BRACKET

- 1960-66 Pickup (Left hand chrome plated outside rearview)
- P6066-16069-CL each**24.95
- 1960-66 Pickup (Right hand chrome plated outside rearview)
- P6066-16069-CR each**24.95
- 1960-66 Pickup (Left hand black outside rearview)
- P6066-16069-PL each**19.95
- 1960-66 Pickup (Right hand black outside rearview)
- P6066-16069-PR each**19.95
- 1960-66 Chevy/GMC Pickup (Left hand, stainless steel)
- P6066-16069-SL each**29.95
- 1960-66 Chevy/GMC Pickup (Right hand, stain steel)
- P6066-16069-SR each**29.95
- 1967-72 Pickup (Left hand s-steel outside, just like original)
- P6772-16069-CL each**27.95
- 1967-72 Pickup (Right hand plated outside, stainless steel)
- P6772-16069-CR each**27.95
- 1967-72 Pickup (Left hand black, like original)
- P6772-16069-PL each**19.95
- 1967-72 Pickup (Right hand black, like original)
- P6772-16069-PR each**19.95

REAR VIEW MIRROR SCREWS

- (For support bracket) For inside or outside mirror.
- 1947-72 Pickup
- P4754-16069-MB each**1.95
- 1947-72 Pickup
- P4772-16068-SK kit**2.95
- 1955-59 Pickup
- P5559-16069-SC set.**95
- 1960-66 Pickup
- P6066-16069-SC set.**95
- 1967-71 Pickup
- P6771-16069-SC set.**1.95
- 1967-72 Pickup (sport mirror)
- P6772-16069-SM set**95

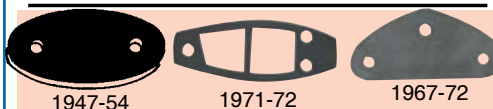

MIRROR ARM GASKET

- For outside rearview mirror.
- 1947-54 Pickup (Left hand)
- P4754-16069-G each**95
- 1955-59 Pickup
- P5559-16069-OMG each**95
- 1960-66 Chevy/GMC (Left hand with molded lip)
- P6066-16069-LG each**1.95
- 1960-66 Chevy/GMC (Right hand with molded lip)
- P6066-16069-RG each**1.95
- 1960-66 Pickup (Exterior)
- P6062-16069-MAG each**95
- 1967-72 Pickup (Exterior w/ molded lip, fits either side)
- P6772-16069-MAG each**95
- 1971-72 Pickup (Left hand)
- P7172-16069-GL each**5.95
- 1971-72 Pickup (Right hand)
- P7172-16069-GR each**5.95

MIRROR TO REINFORCEMENT RETAINER

- 1973-84 Ser 10-30
- P7384-16069-D each**16.95

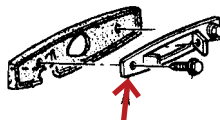

SUNVISOR CORNER EDGE CLIPS

- Stainless steel (finishing edging on visors)
- 1947-59 Pickup
- P4759-16070-ECL pair**1.95



SUNVISOR SCREW SET

- Req. 2 sets per vehicle, does both sunvisors and hooks.
- 1955-59 Pickup
- P5559-16070-AS set.**1.95
- 1967-72 Pickup
- P6772-16070-AS set.**2.95



INTERIOR SUNVISOR BRACKET

- Not chrome.
- 1947-53 Pickup (Left hand)
- P4753-16070-LBRK each.**24.95
- 1947-53 Pickup (Right hand)
- P4753-16070-RBRK each**24.95
- 1954-55 Pickup (Left hand)
- P5455-16070-BRKL each.**24.95
- 1954-55 Pickup (Right hand)
- P5455-16070-BRKR each**24.95
- 1955-59 Pickup (Left hand)
- P5559-16070-BRKL each.**24.95
- 1955-59 Pickup (Right hand)
- P5559-16070-BRKR each**24.95
- 1960-66 Pickup (Left hand)
- P6066-16070-BRKL each.**24.95
- 1960-66 Pickup (Right hand)
- P6066-16070-BRKR each**24.95
- 1967-72 (Fits Left hand or Right hand)
- P6772-16070-BRKT each.**29.95



SUNVISOR HOOKS

- Moulded plastic, black.
- This is what the visors hook to when in normal position.
- 1967-72 Chevy/GMC
- P6772-16071-BLK pair.**9.95



INTERIOR SUNVISOR PADS

- Brackets not included.
- 1947-53 Pickup (Brown)
- P4753-16070-BRN each.**24.95
- 1947-53 Pickup (Gray)
- P4753-16070-GRY each.**24.95
- 1947-54 Pickup (Black)
- P4754-16070-BLK each**24.95
- 1947-53 Pickup (Dark gray)
- P4753-16070-DGRY pair**24.95
- 1947-53 Pickup (Tan)
- P4753-16070-TAN pair.**24.95
- 1954 Pickup
- 1955 Pickup (1st Series) (Black)
- P5455-16070-BLK each**26.95
- 1954 Pickup
- 1955 Pickup (1st Series) (Brown)
- P5455-16070-BRN each.**26.95
- 1954 Pickup
- 1955 Pickup (1st Series) (Dark grey)
- P5455-16070-DGRY each**26.95
- 1954 Pickup
- 1955 Pickup (1st Series) (Tan)
- P5455-16070-TAN each**29.95
- 1955 Pickup (2nd Series) (Black)
- P5559-16070-BLK each**26.95

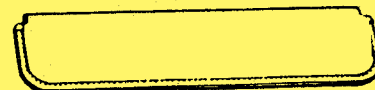



DOORS, MIRRORS, WINDSHIELD, INTERIOR PARTS

Sunvisor pads cont...



- 1955 Pickup (2nd Series)
1959 Pickup
(Brown)
P5559-16070-BRN each26.95
- 1955 Pickup (2nd Series)
1959 Pickup
(Dark grey)
P5559-16070-DKG each26.95
- 1955 Pickup (2nd Series)
1959 Pickup
(Tan)
P5559-16070-TAN each26.95
- 1960-66 Pickup (Beige)
P6066-16070-BGE each26.95
- 1960-66 Pickup (Black)
P6066-16070-BLK each32.95
- 1960-66 Pickup (Gray)
P6066-16070-GRY each32.95



GRAINED VINYL SUNVISORS

Original style walrus grain vinyl. Does not include rod or mounting brackets. You may slip on old visor rods.

- 1967-72 Chevy Pickup (Black)
P6772-16070-BLK pair69.95
- 1967-72 Chevy Pickup (Blue)
P6772-16070-BLU pair89.95
- 1967-72 Chevy Pickup
(Dark green sunvisor, correct oxen grain)
P6772-16070-DGR pair89.95
- 1967-72 Chevy/GMC Pickup, Blazer, Suburban
(Dark saddle. Correct color for 1970-72 only.)
P6772-16070-DS pair89.95
- 1967-72 Chevy Pickup (Off white)
P6772-16070-OW pair89.95
- 1967-72 Chevy/GMC Pickup, Blazer, & Sub (Red)
P6772-16070-RD pair89.95
- 1973-87 Pickup and Suburban (Black)
P7387-16070-BLK pair69.95
- 1973-87 Pickup, Blazer, and Sub (Dark saddle)
P7387-16070-DKSD pair69.95
- 1973-87 Pickup, Blazer, and Sub (Medium green)
P7387-16070-GRN pair69.95
- 1973-87 Pickup and Suburban (Light buckskin)
P7387-16070-LBKS pair69.95
- 1973-87 Pickup, Blazer, and Sub (Light gray)
P7387-16070-LGRY pair69.95
- 1973-87 Pickup, Blazer, and Suburban (Maroon)
P7387-16070-MAR pair69.95
- 1973-87 Pickup, Blazer, and Sub (Medium blue)
P7387-16070-MBL pair69.95
- 1973-87 Pickup, Blazer, and Sub (Medium gray)
P7387-16070-MGRY pair69.95
- 1973-87 Pickup, Blazer, and Sub (Navy blue)
P7387-16070-NBL pair69.95
- 1973-87 Pickup, Blazer, Suburban (Off white)
P7387-16070-OWH pair69.95



DASH PANEL

- Die stamped steel.
1947-53 Chevy
P4753-16080-DP each349.95



INSTRUMENT PANEL STEERING COLUMN LOWER COVER

- 1973-78 Ser 10-30, Blazer, Jimmy
1979-84 Ser 10-30
P7384-16081-A each8.95



DASH PAD MOUNTING CLIP

- 1973-91 Dash pad clip
P7391-16090-CLP each2.95



DASH PAD APPLIQUE

- 1978 Pickup (w/ AC) exc deluxe instrument panel
1979-80 Pickup (w/ AC)
P7880-16090-D each79.95



DASH PAD MOUNTING KIT

- Contains all correct screws, nuts, and j-nuts to attach the dash pad.
1967-72 Pickup
P6772-16100-K kit2.95



GLOVE BOX DOOR

- Black, die stamped steel.
1955-59 Chevy GMC
P5559-16110-A each84.95



ASH TRAY KNOB

- 1940-46 Pickup (Rose tan)
P4046-16120-A each9.95
- 1947-53 Pickup (Chrome)
P4753-16120-C each9.95
- 1960-63 Pickup
P6063-16120-KN each11.95
- 1964-66 Pickup
P6466-16120-KN each11.95
- 1967-72 Pickup (Woodgrain)
P6772-12016-AS each5.95

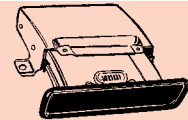

COMPLETE DASH ASHTRAY

- 1967-72 Chevy Pickup
1967-72 Truck, Blazer, Suburban
P6772-16120-A each39.95
- 1967-72 Chevrolet/GMC Truck (chrome)
P6772-16120-C each49.95



ASH TRAY BUMPERS

- 1967-72 Pickup
P6772-16120-BM pair1.95



ASH TRAY

- Console and rear seat armrest.
1967-78 Chevy Pickup w/ Bucket seats
1979-84 Pickup & Suburban
P6972-16120-A each21.95



COWL SCREEN

- 1973-80 Chevy / GMC (plastic)
P7380-16125-CS each39.95

DOORS, MIRRORS, WINDSHIELD, INTERIOR PARTS

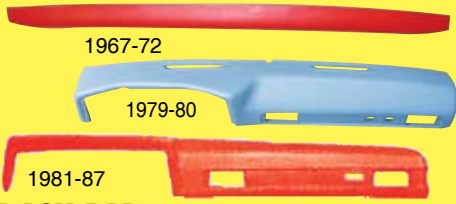

DASH PAD

Exact reproduction.

1967-72 Chevy Pickup, Suburban, Blazer
(Bright blue w/ hardware)

P6772-16090-BL each69.95

1967-72 Ser 10-30 (Cab, Suburban, Blazer)
(Black, with mounting hardware)

P6772-16090-BLK each69.95

1967-72 Pickup, Sub, Blazer (Green w/hardware)

P6772-16090-GR each69.95

1967-72 Chevy Pickup (Gray)

P6772-16090-GRY each69.95

1967-72 Pickup (Red w/ hardware)

P6772-16090-RD each69.95

1967-72 Chevy Pickup, Suburban, Blazer (Saddle)

P6772-16090-SD each69.95

1967-72 Pickup (Sandlewood w/ hardware)

P6772-16090-SND each69.95

1973-78 Pickup (Black)

P7378-16090-BLK each239.95

1973-78 Pickup (Buckskin)

P7378-16090-BS each249.95

1973-78 Pickup (Light blue)

P7378-16090-LB each239.95

1973-78 Chevy/GMC (Med. gray)

P7378-16090-MG each239.95

1973-78 Chevy Pickup (Black, original style vinyl)

P7378-16090-OB each269.95

1973-78 Pickup (Carmine red)

P7378-16090-RD each239.95

1979-80 Pickup (Black, w/vehicle identification
number plate cutout)

P7980-16090-BLK each239.95

1979-80 Pickup, Blazer, Suburban
(Buckskin, with correct vin cutout)

P7980-16090-BS each239.95

1979-80 Pickup, Blazer, Sub (Med blue w/ vin cutout)

P7980-16090-MB each239.95

1979-80 Pickup, Blazer, Suburban (Med. gray, used
w/custom tweed int., comes w/correct vin cutout)

P7980-16090-MG each239.95

1979-80 Pickup, Blazer, Suburban (Medium red)

P7980-16090-MR each239.95

1979-80 Chevy Pickup (Black, original style vinyl)

P7980-16090-OB each269.95

1979-80 Pickup, Blazer, Sub

(Carmine red w/ correct vin cutout)

P7980-16090-R each239.95

1981-87 All (Dark blue)

P8187-16090-BLU each289.95

1981-87 All (Dark brown)

P8187-16090-BR each289.95

1981-87 All (Medium gray)

P8187-16090-GRY each289.95

1981-87 Pickup

1981-91 Blazer, Suburban

(Replace old dash pad with original style dash
pad of vinyl over foam)

P8187-16090-OB each269.95

1981-87 All models (Carmine red)

P8187-16090-R each289.95

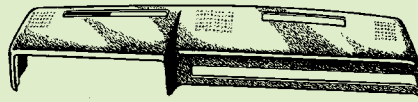

DASH CAP

ABS moulded plastic made to snap over and
completely cover your existing dash, black in
color but may be dyed.

1967-72 Pickup

P6772-16080-CAP each49.95

1973-80 Pickup

P7380-16080-CAP each89.95

1981-87 Pickup

P8187-16080-CAP each89.95



COWL VENT DRAIN HOSE

1933-46 Pickup

P3346-16127-A each3.95

1947-54 Pickup

P4754-16127-DH each3.95

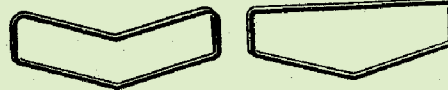

COWL VENT GASKET

Foam type as original.

1936-46 Pickup

P3946-16140-A each5.95

1947-53 Pickup

P4753-16140-A each5.95

1954-55 Pickup

P54-16140-A each5.95

1960-66 Pickup (2 pcs.)

P6066-16140-A set5.95



SIDE VENT GASKET

Foam type as original.

1947-50 Pickup

P4750-16140-A each3.95

Through outside of cowl, 2 pcs.

1955-59 Pickup

P5559-16140-AS pair4.95

**Don't punish
your truck any
longer.
Why wait?
Get it now!**



INSIDE COWL VENT GASKET

Inside vent door.

1955-59 Pickup

P5559-16140-BS pair3.95

1960-66 Chevy & GMC

P6066-16140-BS set7.95

1967-72 Pickup

P6772-16140-BS pair5.95

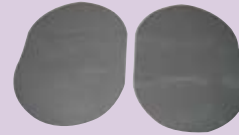

COWL VENT VALVE SEAL

1967-72 Pickup

P6772-16140-AS pair4.95

A/C SHUT OFF VALVE



1967-72 Pickup

P6772-16140-F each49.95

**We appreciate
your business!**



**Gotta tough
question?
Joe is ready
to help!**



DOORS, MIRRORS, WINDSHIELD, INTERIOR PARTS

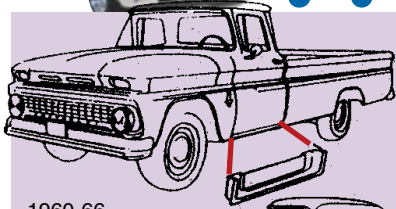

1960-66

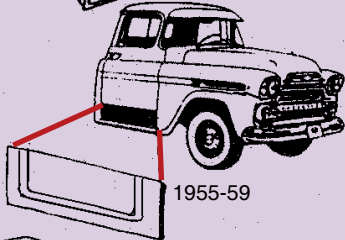

1955-59

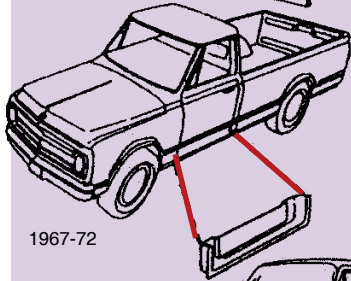

1967-72

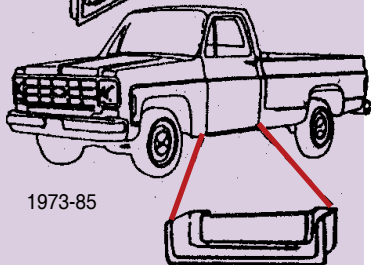

1973-85

INNER DOOR BOTTOM

Perfectly fits your original doors. Dye stamped with curved edges.

- 1936-38 Pickup (Left hand)
- P3638-16150-IDBL each 99.95**
- 1936-38 Pickup (Right hand)
- P3638-16150-IDBR each 99.95**
- 1939-46 Pickup (Left hand)
- P3946-16150-IDBL each 99.95**
- 1939-46 Pickup (Right hand)
- P3946-16150-IDBR each 99.95**
- 1947-55 Chevy / GMC (Fits 35 1/2 x 10 1/2, left hand)
- P4755-16150-IDBL each 34.95**
- 1947-55 Chevy / GMC (Fits 35 1/2 x 10 1/2, right hand)
- P4755-16150-IDBR each 34.95**
- 1955-59 Chevy/ GMC Pickup (Left hand)
- P5559-16150-IDBL each 89.95**
- 1955-59 Chevy/GMC Pickup (Right hand)
- P5559-16150-IDBR each 89.95**
- 1960-66 Pickup, Suburban, Panel (Left hand)
- P6066-16150-IDBL each 49.95**
- 1960-66 Pickup, Suburban, Panel (Right hand)
- P6066-16150-IDBR each 49.95**
- 1967-72 Pickup, Suburban, Blazer, Jimmy (Left hand)
- P6772-16150-IDBL each 39.95**
- 1967-72 Pickup, Suburban, Blazer, Jimmy (Right hand)
- P6772-16150-IDBR each 39.95**
- 1973-85 Pickup, Suburban, Blazer, Jimmy (Left hand)
- P7385-16150-IDBL each 39.95**
- 1973-85 Pickup, Suburban, Blazer, Jimmy (Right hand)
- P7385-16150-IDBR each 39.95**

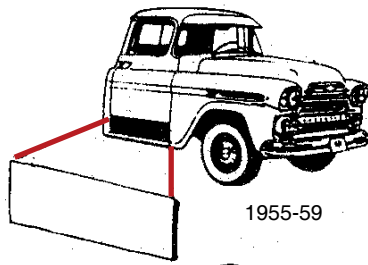

1955-59

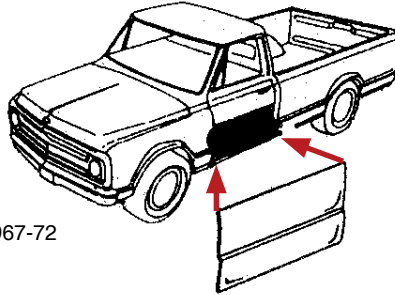

1967-72

OUTER LOWER DOOR SKIN

Extends up to beltline & includes 3 right angle edges to bend over your door frame.

- 1936-38 Pickup (Left hand)
- P3638-16150-LLDS each 119.95**
- 1936-38 Pickup (Right hand)
- P3638-16150-RLDS each 119.95**
- 1939-46 Pickup (Left hand)
- P3946-16150-LLDS each 119.95**
- 1939-46 Pickup (Right hand)
- P3946-16150-RLDS each 119.95**
- 1947-55 Chevy, GMC
- Fits 35 3/4 x 10 1/2, left hand.
- P4755-16150-LLDS each 29.95**
- 1947-55 Chevy / GMC
- Fits 35 3/4 x 10 1/2, right hand
- P4755-16150-RLDS each 29.95**
- 1955-59 Pickup & Panel (Left hand, 11" high)
- P5559-16150-LLDS each 36.95**
- 1955-59 Pickup, Panel (Right hand, 11" high)
- P5559-16150-RLDS each 36.95**
- 1960-66 Chevy/GMC Pickup
- 11" high, fits left hand or right hand door. Uni-versal.
- P6066-16150-LDS each 24.95**
- 1967-72 Pickup, Panel, Suburban, Blazer, Jimmy
- Right hand
- P6772-16150-RLDS each 39.95**
- 1967-72 Pickup, Panel, Suburban, Blazer, Jimmy
- Left hand
- P6772-16150-LLDS each 39.95**
- 1973-85 Pickup, Suburban, Blazer, Jimmy
- Left hand
- P7385-16150-LLDS each 39.95**
- 1973-85 Pickup, Suburban, Blazer, Jimmy
- Right hand
- P7385-16150-RLDS each 39.95**

We accept Visa, Master Card, and Discover.



NEW!



DOOR ASSEMBLY, DIE STAMPED STEEL

Just like original. Must be shipped truck line.

- 1947-50 Chevy Pickup (Left hand)
- P4750-16150-LH each 499.95**
- 1947-50 Chevy Pickup (Right hand)
- P4750-16150-RH each 499.95**
- 1952-55 Chevy/GMC Pickups (Left hand)
- P5255-16150-LH each 449.95**
- 1952-55 Chevy/GMC Pickup (Right hand)
- P5255-16150-RH each 499.95**
- 1955-59 Pickup (Left hand)
- P5559-16150-LH each 499.95**
- 1955-59 Pickup (Right hand)
- P5559-16150-RH each 499.95**

NEW!



DOOR ASSEMBLY, DIE STAMPED STEEL

Just like original. Must be shipped by truck.

- 1964-66 Pickup (left hand)
- P6466-16150-LH each 559.95**
- 1964-66 Pickup (right hand)
- P6466-16150-RH each 559.95**
- 1967-72 Chevy/GMC Pickup (left hand)
- P6772-16150-LH each 299.95**
- 1967-72 Chevy/GMC Pickup (right hand)
- P6772-16150-RH each 299.95**
- 1969-71 Blazer (left hand)
- P6971-16150-BLH each 299.95**
- 1969-71 Blazer (right hand)
- P6971-16150-BRH each 299.95**
- 1973-76 Pickup (Left hand)
- P7376-16150-LH each 129.95**
- 1973-76 Pickup (Right hand)
- P7376-16150-RH each 129.95**
- 1977-89 Pickup (Left hand)
- P7789-16150-LH each 129.95**
- 1977-89 Pickup (Right hand)
- P7789-16150-RH each 129.95**

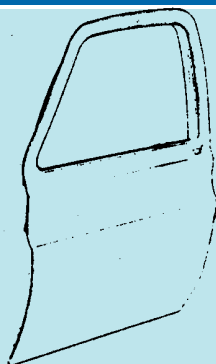

FULL DOOR SKIN

This is the outer skin. Die stamped steel.
1973-87 Pickup, Blazer, Jimmy (left hand)
P7387-16150-LH each99.95
1973-87 Pickup, Blazer, Jimmy (right hand)
P7387-16150-RH each59.95



ARM REST TRIM

Stainless steel, 3 pcs w/ clips.
1955-66 Pickup
P5559-16155-SSK each15.95



COMPLETE ARM REST

Fully upholstered & assembled, complete w/template and screws, fits either side.
1955-66 Pickup (Beige)
P5566-16155-BG each39.95
1955-66 Pickup (Black)
P5566-16155-BLK each39.95
1955-66 Chevy/GMC Pickup (Brown)
P5566-16155-BRN each39.95
1955-66 Pickup (Gray)
P5566-16155-GRY each39.95
1955-66 Chevy/GMC Pickup (Parchment)
P5566-16155-PAR each39.95
1955-66 Pickup (Red)
P5566-16155-RD each39.95



ARM REST SCREW

1972 Pickup
P72-16155-SC each95
1974-78 (2wd, 4wd, Ser. 10/30 Blazer, Jimmy)
P7478-16155-S each4.95

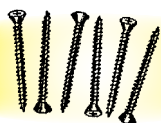

ARM REST SCREW SET

1967-72 Pickup
P6772-16155-SC set.2.95

Arm Rests



1967-71, red



1964-67



1947-55, brown

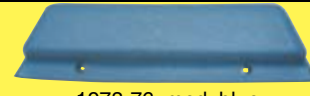

1973-76, med. blue

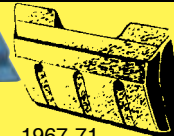

1967-71



1971-72, blue



1977-80

ARM REST

Complete with mounting hardware.
1947-55 Pickup (Black, fits either side)
P4754-16155-BLK each39.95
1947-54 Pickup (Brown, fits either side)
P4754-16155-BRN each39.95
1947-55 Pickup (Maroon, fits either side)
P4754-16155-MAR each44.95
1947-55 Pickup (Gray, fits either side)
P4754-16155-RPG each39.95
1964-67 Pickup (Black, fits either side)
P6467-16155-BLK each24.95
1967-71 Pickup (Black, fits either side)
P6770-16155-A each24.95
1967-71 Chevy Pickup (Blue, fits either side)
P6770-16155-BL each24.95
1967-71 Chevy Pickup (Green, fits either side)
P6770-16155-GR each24.95
1967-71 Chevy Pickup (Parchment, fits both sides)
P6770-16155-PARCH each24.95
1967-71 Pickup (Red, fits either side)
P6770-16155-RD each26.95
1967-71 Chevy Pickup (Saddle, fits either side)
P6770-16155-SD each24.95
1967-71 Pickup, Blazer, Suburban, Crew Cab Black, (fits either side)
P6771-16155-BLK pair.19.95
1969-72 Chevrolet/GMC Blazer and Suburban (Left hand. For rear bench seat. Black.)
P6972-16155-RL each24.95
1969-72 Blazer and Suburban (Right hand. For rear bench seat. Black.)
P6972-16155-RR each24.95
1971-72 Chevy Pickup Deluxe (Blue, fits left hand)
P72-16155-BLL each24.95
1971-72 Chevy Pickup Deluxe (Blue, fits right hand)
P72-16155-BLR each24.95
1971-72 Chevy Pickup Deluxe (Green, left hand)
P72-16155-GRL each24.95
1971-72 Chevy Pickup Deluxe (Green, right hand)
P72-16155-GRR each24.95
1971-72 Chevy Pickup Dlx (Parchment, left hand)
P72-16155-PARR each24.95
1971-72 Chevy Pickup Dlx (Parchment, right hand)
P72-16155-PARR each24.95
1971-72 Chevy Pickup Deluxe (Saddle, left hand)
P72-16155-SADL each24.95
1971-72 Chevy Pickup Deluxe (Saddle, right hand)
P72-16155-SADR each24.95
1972 Chevy (Red, left hand)
P72-16155-RL each24.95
1972 Chevy (Red, right hand)
P72-16155-RR each24.95
1972 Chevy Pickup (Gray, left hand)
P72-16155-GRY each19.95
1972 Chevy Pickup (Gray, right hand)
P72-16155-RGRY each19.95

1972 Pickup (Black, fits left hand)
P72-16155-BL each24.95
1972 Pickup (Black, fits right hand)
P72-16155-BR each24.95
1972 Chevy/GMC (Gray left hand)
P72-16155-GL each24.95
1972 Chevrolet/GMC (Gray right hand)
P72-16155-GR each24.95
1973-76 Pickup, Blazer, Suburban, Crew Cab (Black, fits left hand or right hand, front or rear)
P7376-16155-BLK each34.95
1973-76 Pickup, Blazer, Suburban (Buckskin, fits left hand or right hand side)
P7376-16155-BS each34.95
1973-76 Pickup, Blazer, Suburban (Carmine red, fits lh or rh side)
P7376-16155-LR each34.95
1973-76 Pickup, Blazer, Suburban (Medium blue. Fits either right or left side)
P7376-16155-MB each34.95
1973-76 Pickup, Blazer, Suburban (Med. gray arm rest pad. Fits left or right side.)
P7376-16155-MG each34.95
1973-76 Pickup, Blazer, Suburban (Carmine red, fits either left or right.)
P7376-16155-R each34.95
1972-73 Pickup, Blazer, Suburban (For front or rear, gray in color, can dye to match. Fits either right or left side)
P7376-16155-PR pair.49.95
1977-80 Pickup, Blazer, Suburban, Crew Cab (Front) (Black armrest pad, fits lh or rh)
P7780-16155-BLK each34.95
1977-80 Pickup, Blazer, Suburban (Buckskin armrest pad, fits lh or rh side)
P7780-16155-BS each34.95
1977-80 Pickup, Blazer, Suburban (Medium blue. Fits either right or left side)
P7780-16155-MB each34.95
1977-80 Pickup, Blazer, Suburban (Medium gray. Fits either right or left side)
P7780-16155-MG each34.95
1977-80 Pickup, Blazer, Suburban (Medium red arm rest pad. fits right or left)
P7780-16155-MR each34.95
1977-80 Pickup, Blazer, Suburban (Carmine red. Fits right or left side.)
P7780-16155-R each34.95
1977-80 Pickup, Blazer, Suburban (Front, gray, dye to match. Fits right or left side)
P7780-16155-PR pair.49.95
1977-80 Suburban, Crew Cab (Rear, black. Fits either right or left side)
P7780-16155-RBLK each.49.95
1977-80 Suburban, Crew Cab (Rear, gray, dye to match. Fits either right or left side)
P7780-16155-RPR pair.54.95



DOORS, MIRRORS, WINDSHIELD, INTERIOR PARTS

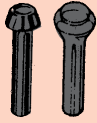

DOOR LOCK BUTTON

- 1967-68 Pickup (Black)
- P6768-16157-BL each3.95**
- 1967-68 Pickup (Medium brown)
- P6768-16157-BR each3.95**
- 1967-68 Pickup (Medium blue)
- P6768-16157-MB each3.95**
- 1967-68 Pickup (Off white)
- P6768-16157-OW each3.95**
- 1967-68 Pickup (Red)
- P6768-16157-R each3.95**
- 1967-68 Pickup (Saddle)
- P6768-16157-SDL each3.95**
- 1969-72 Pickup (Black)
- P6972-16157-BLK each3.95**
- 1969-72 Pickup (Medium brown)
- P6972-16157-BRN each3.95**
- 1969-72 Pickup (Medium blue)
- P6972-16157-MB each3.95**
- 1969-72 Pickup (Off white)
- P6972-16157-OW each3.95**
- 1969-72 Pickup (Red)
- P6972-16157-RD each3.95**
- 1969-72 Pickup (Saddle)
- P6972-16157-SAD each3.95**



INTERIOR DOOR PANEL SCREW SET

- Phillips screw set with special washers
- 1947-53 Pickup
- P4753-16165-SCA set11.95**



Brown



Gray

INTERIOR STANDARD DOOR PANELS

- 1947-54 Pickup (Black)
- P4754-16165-BLK pair14.95**
- 1947-54 Pickup (Brown)
- P4754-16165-BRN pair11.95**
- 1947-54 Pickup (Gray)
- P4754-16165-GRY pair14.95**



1947-55 Maroon



1947-55 Black

DELUXE INTERIOR DOOR PANELS

- 1947-55 Pickup (Black)
- P4755-16165-DB pair26.95**
- 1947-55 Pickup (Maroon - as original on 1947-53)
- P4755-16165-DM pair26.95**
- 1947-53 Pickup (Med. brown - as original on 1947-53)
- P4755-16165-DMB pair26.95**
- 1954-55 Pickup (Dark blue)
- P5455-16165-DDB pair69.95**
- 1954-55 Pickup (w/ deluxe cab interiors, Dark green)
- P5455-16165-DDG pair69.95**



INTERIOR DOOR PANEL

- Interior door panel. Die stamped steel.
- 1955-59 Chevy (left hand)
- P5559-16165-L each79.95**
- 1955-59 Pickup (right hand)
- P5559-16165-R each79.95**

Dig Camaros?

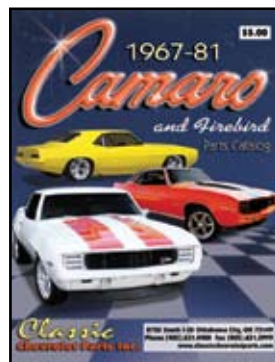

Don't miss our NEW Camaro catalog! Order yours today!

CHEVROLET Ave. WE USE Genuine CHEVROLET PARTS CHEVROLET PARKING ONLY

Mr. Buffer Gas Tank Etch

Find these great items in our Accessories & Decals section!

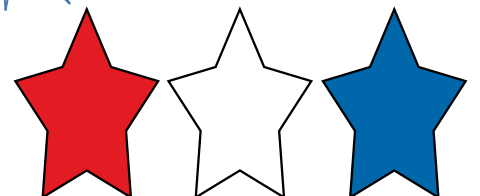



INTERIOR DOOR PANELS



1967-68

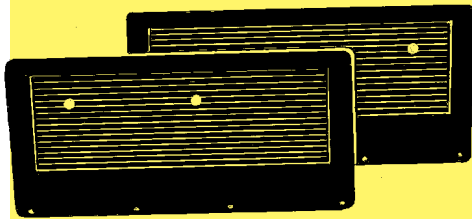

1967-71 Black



1972 Walnut



1972 Woodgrain

INTERIOR DOOR PANELS

ABS plastic vacuumed-formed backing plates. Ready for installation, pre assembled.

- 1967-68 Pickup (Aqua)
- P6768-16165-AQ pair199.95**
- 1967-68 Chevy Pickup (Bright blue)
- P6768-16165-BB pair199.95**
- 1967-68 Chevy Pickup (Black)
- P6768-16165-BK pair199.95**
- 1967-68 Chevy Pickup (Bright red)
- P6768-16165-BR pair199.95**
- 1967-68 Chevy Pickup (Dark aqua)
- P6768-16165-DA pair204.95**
- 1967-68 Chevy Pickup (Light green)
- P6768-16165-LG pair199.95**
- 1967-68 Chevy Pickup (Light saddle)
- P6768-16165-LS pair199.95**
- 1967-68 Chevy Pickup (Metallic green)
- P6768-16165-MG pair199.95**
- 1967-68 Chevy Pickup (Off white)
- P6768-16165-OW pair204.95**
- 1967-68 Chevy Pickup (Red)
- P6768-16165-RD pair199.95**
- 1967-71 Pickup, Blazer, Suburban (black)
- P6771-16165-BLK pair99.95**
- 1967-71 Chevy/GMC Pickup, Suburban, Panel, and Blazer (Metal)
- P6771-16165-M pair104.95**
- 1967-72 Pickup (Colonial walnut, plastic)
- P6772-16165-CW pair89.95**
- 1967-72 Pickup (Woodgrain, aluminum)
- P6772-16165-WGP pair149.95**



1969



1970-71



1972

- 1969 Chevy Pickup (Aqua)
- P69-16165-AQ pair269.95**
- 1969 Chevy Pickup (Bright blue)
- P69-16165-BB pair269.95**
- 1969 Chevy Pickup (Black)
- P69-16165-BLK pair269.95**
- 1969 Chevy Pickup (Dark aqua)
- P69-16165-DA pair269.95**
- 1969 Chevy Pickup (Dark blue)
- P69-16165-DB pair269.95**
- 1969 Chevy Pickup (Red)
- P69-16165-RD pair269.95**
- 1969 Chevy Pickup (Saddle)
- P69-16165-SD pair269.95**
- 1970-71 Pickup (Blue)
- P7071-16165-BL pair269.95**
- 1971-72 Pickup (black)
- Vinyl w/chrome & woodgrain trim.
- P7071-16165-BLK pair269.95**
- 1970-71 Pickup (green)
- Vinyl w/chrome & woodgrain trim.
- P7071-16165-GR pair269.95**
- 1970-71 Pickup (Parchment)
- P7071-16165-PAR pair269.95**
- 1970-71 Pickup (Red)
- Vinyl w/chrome & woodgrain trim.
- P7071-16165-RD pair269.95**
- 1970-71 Pickup (saddle)
- Vinyl w/chrome & woodgrain trim.
- P7071-16165-SD pair269.95**
- 1972 Pickup (Black)
- Has correct inlaid scroll pattern.
- P72-16165-BL pair159.95**



1973-76



1977-80



1977-80

- 1973-76 Pickup, Blazer, Suburban, Crew Cab, Silverado
- Front door panel without power.
- P7376-16165-A pair149.95**
- 1973-76 Suburban, Crew Cab, Silverado
- Rear door panels, without power windows.
- P7376-16165-AR pair139.95**
- 1973-76 Chevy Pickup
- Front door panel with power windows.
- P7376-16165-B pair149.95**
- 1976 Chevy Pickup, Suburban, Crew Cab
- Rear door panel with power windows.
- P7376-16165-BR pair139.95**
- 1977-80 Pickup, Blazer, Suburban, Crew Cab, Cheyenne
- Front door panels, w/out power windows, black.
- P7780-16165-A each149.95**
- 1977-80 Suburban, Crew Cab, Cheyenne
- Rear door panels without power windows.
- P7780-16165-AR each139.95**
- 1977-80 Chevy
- Front door panels with power windows.
- P7780-16165-B pair159.95**
- 1977-80 Chevy Pickup, Suburban, Crew Cab
- Rear door panels, with power windows.
- P7780-16165-BR pair139.95**
- 1977-80 Chevy/GMC Pickup
- Molded ABS plastic door panels for front doors. Works with Silverado type doors only.
- P7780-16165-C pair159.95**
- 1977-80 Chevy Pickup Sierra CLA, Cheyenne, High Sierra, Silverado
- For Chevy full size. Must reuse old trim. Silverado style, black.
- P7780-16165-S pair169.95**



DOORS, MIRRORS, WINDSHIELD, INTERIOR PARTS



1967-68



1968

DOOR EMBLEMS

'Custom' w/ fasteners
1967-68 Chevy Pickup

P6768-16165-A pair49.95

'CST' w/ fasteners
1968 Chevy Pickup
1969-72 Blazer

P68-16165-AS pair49.95



FRONT DOOR TRIM PANEL SEAL

1970-72 Ser 10-30 (Panel & Suburban)
1973-78 Ser 10-30, Blazer, Jimmy

P7072-16165-DPS each4.95



INTERIOR DOOR PANEL INSERT

Replacement style.

1977-80 Pickup, Blazer, Suburban (burl grained)

P7780-16165-BURL pair99.95

1977-80 Pickup (silver)

P7780-16165-SLV pair79.95

1977-80 Pickup, Blazer, Suburban (walnut grain)

P7780-16165-WLNT pair99.95

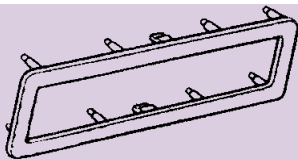

INTERIOR DOOR TRIM PANEL MOULDING

1977-80 Ser 10-30 (Cab 2-dr) Scottsdale, Sierra Grande
Front door moulding

P7780-16166-FT each39.95

1977-80 C10-30 & K10-30 (Cab 2-dr.) Blazer, Jimmy (Cheyenne, High Sierra)
Front moulding, chrome with black insert. Fits right or left side.

P7780-16166-FTA each109.95

1977-80 Pickup

Black, for trucks without pull strap. Fits left or right Cheyenne or High Sierra, can be used with Silverado with pull straps to without pull straps.

P7780-16166-FTB each39.95

1977-80 Cheyenne or High Sierra

All chrome for trucks without pull straps, fits left or right side.

P7780-16166-FTC each69.95

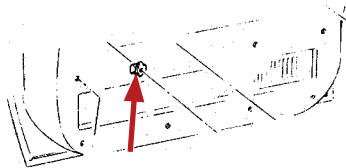

TRIM PANEL RETAINER

Side front, side rear trim panel retainer (screw type).

1977-78 Pickup, Blazer, Jimmy

1979-84 Pickup

P7784-16165-R each95

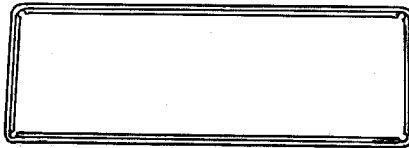

INTERIOR DOOR PANEL METAL FRAMES

Cardboard metal frames w/ union clip.

1947-55 Pickup (Plain steel)

P4754-16166-AM pair.29.95

1947-54 Pickup (Stainless steel)

P4754-16166-ASS pair.69.95

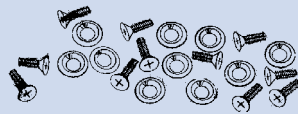

INTERIOR DOOR PANEL SCREW KIT

1947-53 Pickup

P4752-16166-MB kit.4.95

1955 (2nd Series) Pickup

P55-16166-SCA set6.95

1956-66 Pickup

P5666-16166-MB set7.95

1967-71 Pickup

P6771-16166-MB set5.95



DOOR PANEL FRAME CLIPS

1947-54 Pickup (Cardboard clips (at bottom center))

P4754-16166-CL pair3.95

1947-55 Pickup (Metal frame mounting clips)

P4755-16166-CL pair3.95



DOOR PANEL RETAINER CLIPS

1953-54 Pickup

P5354-16166-CL kit3.95



DOOR PANEL FOAM SPACERS

(12 pc. set)

1947-55 Pickup

P4755-16166-SP each9.95



GARNISH MOLDING FASTENERS

Inner door window garnish molding screw set.

1955-59 Pickup

P5559-16166-GMB set.14.95



DOOR PANEL FASTENER KIT

Contains screws and 16 clips

1971-72 Pickup

P7172-16166-K kit7.95



DOOR PANEL CLIP

1972 Pickup

P72-16166-CLA each4.95

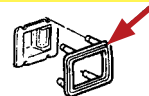

FRONT DOOR HANDLE ACCESS HOLE MOULDING

1977-80 Ser 10-30, Blazer, Jimmy (Cheyenne, High Sierra, Silver Sierra Classic)

P7780-16166-A each18.95

1977-80 (2wd. 4wd. Ser. 10-30 (Cab, 2-dr)

Scottsdale, Sierra Grande)

P7780-16166-B each17.95

Don't punish your truck any longer. Why wait? Get it now!





VENT WINDOW HANDLE PIN & WASHER KIT

1968-72 Pickup
P6872-16172-PWK set19.95



DOOR VENT GLASS

1939 Pickup (Clear)
P39-16174-A each39.95
 1941 Pickup (Clear)
P41-16174-A each39.95
 1951-54 Pickup (Clear)
P5154-16174-A each39.95
 1955-59 Pickup (Clear)
P5559-16174-A each39.95
 1960-63 Pickup (Clear)
P6063-16174-A each39.95
 1964-66 Pickup (Clear)
P6466-16174-A each39.95
 1967-72 Chevy/GMC Pickup, Blazer, and Suburban
 (Clear glass with hole for latch. Fits either side.)
P6772-16174-C each24.95
 1967-72 Chevy/GMC Pickup, Blazer, and Suburban
 (Fits either side, tinted glass with hole for latch.)
P6772-16174-T each24.95
 1973-79 Chevy (This is a curved glass.)
P7379-16174-AL each99.95
 1973-79 Chevy (This is a curved clear glass.)
P7379-16174-AR each99.95
 1973-80 Pickup (Tinted)
P7380-16174-B each169.95



VENT WINDOW RIVET TOOL

Special tool for installing vent rubber rivets.
 All
B-16175-RT each4.95



VENT WINDOW GLASS SETTING

Rubber
 1947-54 Pickup
P4754-16175-GSR pair3.95

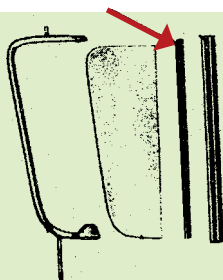

VENT WINDOW REAR EDGE SEAL

Rubber
 1947-55 Pickup
P4754-16175-RAS pair5.95
 1955-66 Pickup
P5559-16175-AS pair5.95
 1967-72 Pickup
P6772-16175-AS pair17.95
 1975-80 Ser 10-30 (left hand)
P7580-16175-LH each59.95
 1975-80 (2wd, 4wd, Ser. 10-30 (right hand)
P7580-16175-RH each59.95



VENT WINDOW PIVOT RIVETS

1951-72 Pickup
P5172-16175-R pair2.95



VENT WINDOW FRAME WITH GLASS ASSEMBLY

1955-59 Pickup
 (Chrome plated frame, comes w/ green tinted glass.)
P5559-16175-A pair279.95
 1955-59 Pickup
 (Painted frame , comes with tinted glass.)
P5559-16175-B pair219.95

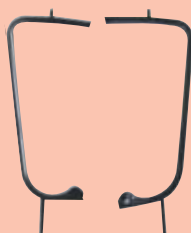

VENT WINDOW FRAME

Painted. Without glass.
 1955-59 Chevy
P5559-16175-BWO pair79.95

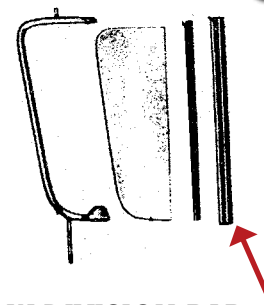

WINDOW DIVISION BAR

With felt, no holes or brackets.
 1955-59 Pickup
P5559-16175-DB each39.95
 1960-63 Pickup
P6063-16175-DB each39.95



1960-63



1951-54

VENT WINDOW SEAL SET

Rubber, 4 pieces. Includes back edge seals.
 1951-54 Pickup
P4754-16175-A pair32.95
 1955-59 Pickup (2nd Series)
P5559-16175-VWS set29.95
 1960-63 Pickup
P6063-16175-VWS set27.95
 1964-66 Pickup
P6466-16175-VWS set29.95
 1967-72 Pickup, Suburban
 1969-72 Blazer
P6772-16175-VWS set29.95
 1973-80 vent window seal set
 1973-80 Chevy GMC
P7380-16175-VWS set49.95
 1981-87 Chevy/GMC all models
 1981-91 Blazer and Suburban
P8191-16175-VWS set49.95



We accept Visa, Master Card, and Discover.



DOORS, MIRRORS, WINDSHIELD, INTERIOR PARTS

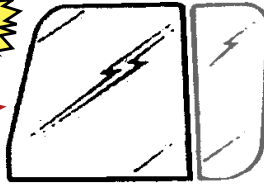

PICKUP DOOR GLASS

Cut to exact specs. Clear glass, will fit either side.

- 1941 Pickup
P41-16180-A each 99.95
- 1942-46 Pickup
P4246-16180-A each 99.95
- 1947-50 Pickup
P4750-16180-A each 99.95
- 1951-55 Pickup (1st Ser)
P5154-16180-A each 99.95
- 1955-59 (2nd Ser) Pickup
P5559-16180-A each 69.95
- 1960-63 Pickup
P6063-16180-A each 99.95
- 1964-66 Pickup
P6466-16180-A each 99.95
- 1967-72 Pickup
P6772-16180-A each 99.95
- 1973-80 Pickup
P7380-16180-A each 99.95
- 1973-80 Pickup (Factory green tint)
P7380-16180-B each 99.95

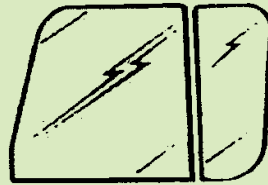

WINDOW GLASS PATTERNS

- 1936-38 Pickup
P3638-16180-PAT set 24.95
- 1939-46 Pickup
P3946-16180-PAT set 24.95
- 1947-50 Pickup
P4750-16180-PAT set 24.95
- 1951-55 Pickup
P5155-16180-PAT set 24.95

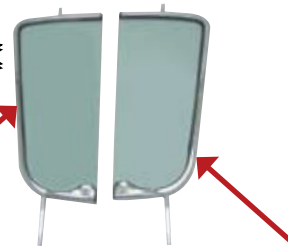

1955-59 SIDE CHROME WINDOW FRAME

Does not come with glass.
1955-59 Chevy (left side)

- P5559-16181-L each** 44.95
- 1955-59 Chevy (right side)
P5559-16181-R each 44.95



VENT WINDOW ASSEMBLY

Complete with division bar, chrome frame, vent window rubber, clear glass, vent handle, and all hardware.

- 1968-72 Pickup, Blazer, and Suburban (left hand)
P6872-16175-CLH each 199.95
- 1968-72 Pickup, Blazer, and Suburban (right hand)
P6872-16175-CRH each 199.95



VENT WINDOW HANDLE

1947-55 Pickup (1st Series) (Chrome plated, left hand)

- P4754-16176-AS pair** 14.95
- 1947-54 Pickup (right hand)
P4754-16176-BS each 14.95
- 1955-59 Pickup (2nd Series) (left hand)
P5559-16176-LH each 14.95
- 1955-59 Pickup (right hand)
P5559-16176-RH each 14.95
- 1960-66 Pickup (left hand)
P6066-16176-LH each 14.95
- 1960-66 Pickup (right hand)
P6066-16176-RH each 14.95
- 1968-72 Pickup (left hand, complete with shaft, pin, and washers)
P6872-16176-LH each 14.95
- 1968-72 Pickup (right hand, complete with handle, shaft, pin, and washers)
P6872-16176-RH each 14.95
- 1973-78 Chevy/GMC Pickup (left hand, includes all hardware)
P7378-16176-LH kit 19.95
- 1973-78 Chevy/GMC Pickup (right hand, includes all hardware)
P7378-16176-RH kit 19.95



VENT WINDOW PILLAR SCREW

- 1967-72 Pickup
P6772-16176-SC set 2.95



OUTER WINDOW SEAL

Rubber. Fits on outside edge of door opening for the glass.

- 1947-50 Pickup
P4750-16183-CS pair 7.95
- 1951-54 Pickup
P5154-16183-DS pair 5.95

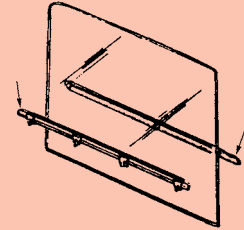

DOOR WINDOW FELT & WIPER KIT

Does both doors with inner and outer wipers, reproduction. 4 piece set

- 1939-46 Pickup
P3946-16183-AS 4 pcs. 19.95
- 1947-50 Pickup (inners only)
P4750-16183-AS pair 39.95
- 1951-55 Pickup (inners only)
P5154-16183-AS pair 34.95
- 1955-59 Pickup
P5559-16183-AS 4 pcs. 39.95
- 1960-63 Pickup
P6063-16183-AS 4 pcs. 44.95
- 1964-66 Pickup
P6466-16183-AS 4 pcs. 49.95
- 1967-72 Pickup
P6772-16183-AS 4 pcs. 44.95
- 1967-72 Suburban
Dye formed w/clips, easy installation, front doors or third door.
P6772-16183-BS 4 pcs. 39.95
- 1973-91 Chevy Pickup
P7391-16183-AS 4 pcs. 44.95



WINDOW RIM SETTING RUBBER

- 1947-50 Pickup
P4750-16183-GLR pair 7.95

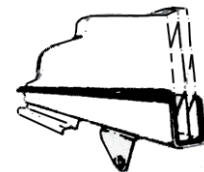

LOWER WINDOW SEAL

- Requires 2.
1955-59 Pickup
P5559-16183-LW each 4.95



DOOR WINDOW STOP BUMPER

Requires 4. Fits on bottom of window track.
1947-55 All (1st Series)

P4755-16190-BM each 1.95

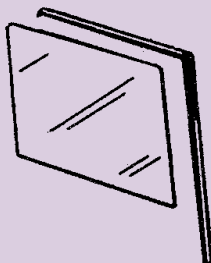

PICKUP TOP AND REAR SIDE DOOR GLASS RUN

Fits either side
1964-66 Chevy/GMC Pickup

P6466-16190-A each 14.95

1967-72 Pickup

P6772-16190-A each 14.95

Top and rear glass run channel. Fits either side.

1973-80 Chevy/GMC

P7380-16190-A each 24.95

1981-87 Chevy/GMC (left hand)

P8187-16190-LH each 29.95

1981-87 Chevy/GMC (right hand)

P8187-16190-RH each 29.95



REAR DOOR GLASS CHANNEL RUNS

1969-72 Blazer

P6972-16190-PR pair 49.95

Check this out!

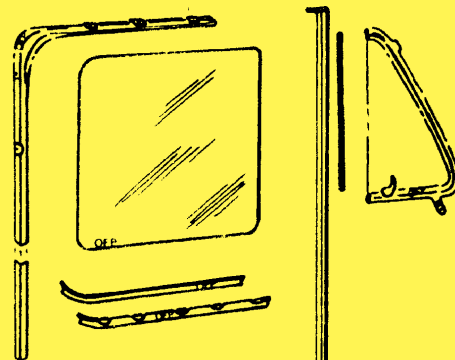

DOOR ANTI-RATTLER KIT

These are the super kits. Each kit includes all the felt pieces above, around and on the sides of the door, the u-shaped felt, all necessary installation clips and or staples. All kits include items for both doors. Each application may vary. This simplifies buying several different pieces into one easy purchase so you save money! Includes upper glass runs - along front and back of glass, inner and outer rubber window seals along bottom of window. Note: 1 kit does both doors.

1939-46 Pickup

P3946-16200-AK kit 49.95

1947-50 Pickup

P4750-16200-AK kit 109.95

1951-55 Pickup (1st Series)

P5155-16200-AK kit 84.95

1955-59 Chevy Pickup

P5559-16200-AK kit 99.95

1960-63 Pickup (w/metal frame around window)

P6063-16200-AK kit 89.95

1960-63 Pickup (w/ out metal frame around glass)

P6063-16200-BK kit 109.95

1964-66 Pickup (w/ safety glass - no frame around window)

P6466-16200-BK kit 89.95

1967-72 Pickup (Exc. 67-70 Suburban, 69-70 Blazer w/ Removable Top)

P6772-16200-AK kit 84.95

1973-80 Chevy/GMC Pickup

P7380-16200-AK set 69.95

1981-87 Pickup

P8187-16200-AK kit 69.95



DOOR RAIL CLIP SET

(4 pc. set)

1955-59 Pickup

P5559-16200-CK set 14.95

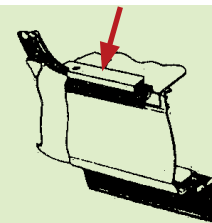

LOWER DOOR SEALS

Cab to door lower rubber seal

1936-46 Pickup

P3646-16225-LA pair 11.95

1947-49 Pickup

P4749-16225-LA pair 14.95

1950-54 Pickup

P5054-16225-LA pair 14.95



LOWER WINDLACE RETAINER

Fits on cab at the bottom of the door opening.

1947-49 Pickup

P4749-16225-RT pair 42.95

1950-54 Pickup

P5054-16225-RT pair 26.95

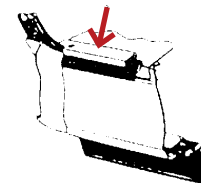

LOWER DOOR SEAL RETAINER ON CAB

Stainless steel

1947-49 Pickup

P4749-16225-RTSS pair. 72.95

1950-54 Pickup

P5054-16225-RTSS pair. 64.95



WINDLACE RUBBER

(Fits on cab)

1947-50 Pickup

P4750-16225-AS pair 24.95

1951-54 Pickup (Black)

P5154-16225-AS roll 29.95

1951-54 Pickup (Brown)

P5154-16225-BS roll 59.95

Service
with a



All-American
Deals



DOORS, MIRRORS, WINDSHIELD, INTERIOR PARTS

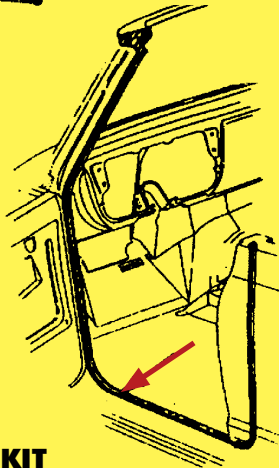
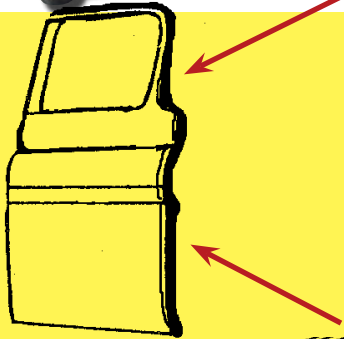

DOOR SEAL KIT

Molded, exactly like original, Super Quality! One kit does both doors.

1947-54 Pickup (Fits on door - glue on)

P4754-16225-AS pair19.95

1955-59 Chevy/GMC Pickup (Fits on door edge, w/clips)

P5559-16225-AS pair29.95

1960-66 Chevy Pickup (Fits on cab)

P6066-16225-BS kit29.95

1967-72 Pickup (w/corner, glues on cab)

P6772-16225-AS set39.95

1967-72 Suburban (does all 3 front doors)

P6772-16225-BS set39.95

1969-72 Blazer (For both front doors)

P6972-16225-AS set69.95

1973-91 Pickup

Snaps over channeling for a snug no leak fit - no clips necessary for installation.

P7391-16225-AS set69.95



FRONT UPPER RUBBER DOOR CAP

Mounts at the top edge of the vent window post.

1973-75 Blazer/Jimmy (Left hand)

P7375-16225-ULH each39.95

1973-75 Blazer/Jimmy (Right hand)

P7375-16225-URH each39.95

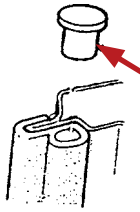

BLAZER DOOR SEAL PLUG

Goes with part #P6972-16225-AS (Blazer front door seal kit)

1969-72 Blazer

P6972-16225-PLG each7.95

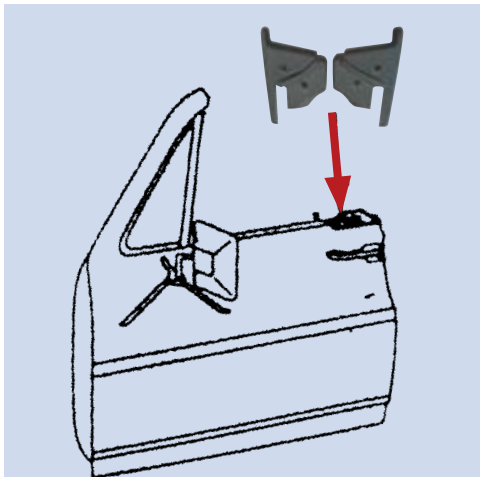

BLAZER REAR OF DOOR END CAPS

Fits on latch side.

1969-72 Blazer/Jimmy

P6972-16225-LC Pair49.95

1973-75 Blazer/Jimmy

P7375-16225-LC pair29.95



SIDE FRONT DOOR WEATHERSTRIP

On door

1979-82 (2wd, 4wd, Ser. 10-30, Cheyenne, High Sierra, Silverado, Sierra Classic) (left hand)

P7982-16225-LH each47.95

1979-82 (2wd, 4wd, Ser. 10-30 Cheyenne, High Sierra, Silverado, Sierra Classic) (right hand)

P7982-16225-RH each47.95

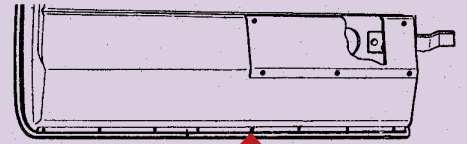

Retainer

LOWER DOOR SEAL RETAINER

Holds rubber in place on bottom of door.

1947-55 Chevy/GMC Pickup (Plain steel)

P4755-16230-A each10.95

1947-55 Pickup (Stainless steel, requires 1 per door)

P4755-16230-SS each13.95

1955-59 Chevy/GMC Pickup (Plain steel)

P5559-16230-A each10.95

1955-59 Pickup (Stainless steel, requires 1 per door)

P5559-16230-SS each13.95

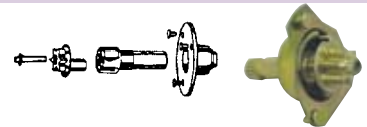

WINDOW REGULATOR REPAIR KIT

1936-46 Pickup

P3646-16260-RBK kit24.95

1955-59 Pickup

P5559-16260-RBK kit24.95

1967-71 Pickup (left hand)

P6771-16260-LRBK kit22.95

1967-71 Pickup (right hand)

P6771-16260-RRBK kit22.95

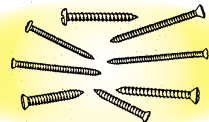

INDOOR DOOR MOULDING SCREW SET

1947-54 Pickup

P4754-16290-MB set2.95



Gotta question?
Ask Mike! He's here to help.

We accept Visa, Master Card, and Discover.

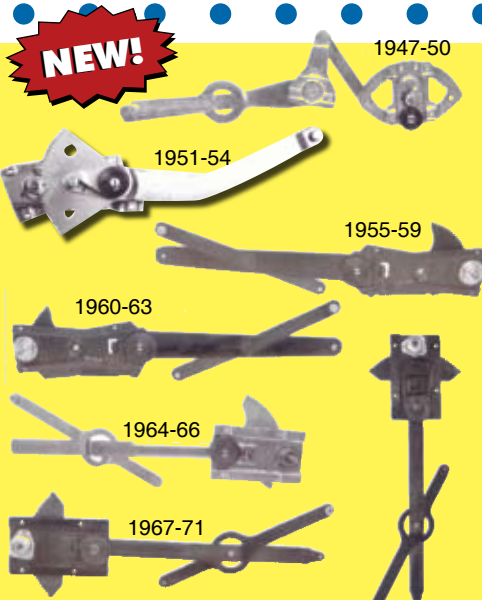

WINDOW REGULATOR

Original style, great quality!
1947-50 Pickup (left hand)

P4750-16260-L each 99.95
1947-50 Pickup (right hand)

P4750-16260-R each 99.95
1951-54 Pickup (left hand)

P5154-16260-L each 79.95
1951-54 Pickup (right hand)

P5154-16260-R each 79.95
1955-59 Pickup (left hand)

P5559-16260-L each 69.95
1955-59 Pickup (right hand)

P5559-16260-R each 69.95
1960-63 Pickup (left hand)

P6063-16260-L each 89.95
1960-63 Pickup (right hand)

P6063-16260-R each 89.95
1964-66 Pickup (left hand)

P6466-16260-AL each 59.95
1964-66 Pickup (right hand)

P6466-16260-AR each 59.95
1967-71 All & Blazer w/ removable top

(left hand)

P6771-16260-L each 39.95
1967-71 All & Blazer (w/ removable top)

(right hand)

P6771-16260-R each 39.95
1972 Ser 10-30 & Blazer (left hand)

P72-16260-L each 39.95
1972 Chevy/GMC Pickup, Blazer, and Suburban

1972 Chevy/GMC (right hand)

P72-16260-R each 39.95

OUTER RUBBER WINDOW SEAL

Fits inside channel, keeps window from rattling around. Just like original.

1936-46 Pickup

P3646-16261-AS set 14.95
1947-50 Pickup

P4750-16261-AS pair 14.95
1951-55 Pickup

P5155-16261-AS pair 8.95



WINDOW CRANK

Clear knob

P6772-16270-CLR each 7.95

1977-Up Pickup

P77-16270-A each 9.95



INSIDE WINDOW CRANK

1939-47 Chevy GMC Pickup

P3947-16270-A each 39.95



WINDOW REGULATOR HANDLE

With black knob, includes screw.

1947-66 All

P4754-16270-BLK each 12.95



INSIDE WINDOW HANDLE

With wire clip, chrome plated with black knob.

1967 All body styles

P67-16270-A each 21.95

1967-76 Chevy/GMC

P6772-16270-A each 7.95



blue



gray



tan

INSIDE DOOR AND WINDOW CRANK HANDLE ESCUTCHEON

Plate behind handle, will also fit behind door handle.

1967-71 Ser 10-30 (Black)

P6769-16270-ESC each 2.95

1967-71 Pickup, Blazer, Suburban (Blue)

P6771-16270-BE each 2.95

1967-71 Pickup, Blazer, Suburban (Gray)

P6771-16270-GYE each 1.95

1967-71 Pickup, Blazer, Suburban (Tan)

P6771-16270-TE each 2.95

1967-71 Chevy (Green)

P6771-16270-GR each 2.95



INSIDE DOOR & WINDOW CRANK HANDLE WASHER

1972 Pickup, Blazer, Suburban

P72-16260-ESC each 1.95



NEW!

INTERIOR DOOR WINDOW GARNISH MOLDING METAL FRAME

1952-55 Chevy/GMC Pickup (Left hand)

P5255-16290-LH each 69.95

1952-55 Chevy/GMC Pickup (Right hand)

P5255-16290-RH each 69.95

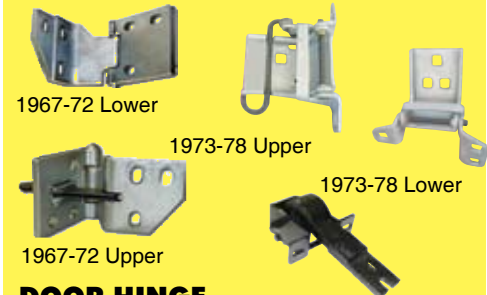

DOOR HINGE

1955-59 Chevy GMC Pickup

Lower, fits either side, requires 2

P5559-16320-LH each 69.95

1955-59 Chevy Pickup

Upper, fits either side, req. 2

P5559-16320-UH each 69.95

1960-66 Chevy Pickup (left hand, upper & lower)

P6066-16320-LH set 129.95

1960-66 Chevy/GMC Pickup (right hand, upper & lower)

P6066-16320-RH set 129.95

1967-72 Ser 10-30

Lower, left hand

P6772-16320-LSL each 39.95

1967-72 Ser 10-30 (Lower, right hand)

P6772-16320-RSL each 39.95

1967-72 All Ser. 10-30 (Upper, left hand)

P6772-16320-LSU each 39.95

1967-72 Ser 10-30 & Blazer (Upper, right hand)

P6772-16320-RSU each 39.95

1973-78 (2wd, 4wd, Ser. 10-30, Blazer, Jimmy)

1979-84 (2wd, 4wd, Ser. 10-30)

(left hand, front)

P7384-16320-LLH each 46.95

1973-78 (2wd, 4wd, Ser. 10-30, Blazer, Jimmy)

1979-84 (2wd, 4wd, Ser. 10-30)

(right hand, front)

P7384-16320-LRH each 49.95

1973-78 (2wd, 4wd, Ser. 10-30, Blazer, Jimmy)

1979-84 (2wd, 4wd, Ser. 10-30)

(left hand, front)

P7384-16320-ULH each 49.95

1973-78 (2wd, 4wd, Ser. 10-30, Blazer, Jimmy)

1979-84 (2wd, 4wd, Ser. 10-30)

(right hand, front)

P7384-16320-URH each 57.95



DOORS, MIRRORS, WINDSHIELD, INTERIOR PARTS



1947-55

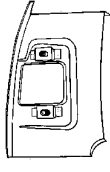

1955-59

LOWER DOOR HINGE REPAIR PANEL

Die stamped steel. Fits outside of door.

1947-55 Chevy Pickup (1st ser.) (left hand)

P4755-16320-LRP each39.95

1947-55 Chevy Pickup (1st ser.) (right hand)

P4755-16320-RRP each39.95

1955-59 Pickup (left hand)

P5559-16320-LRP each49.95

1955-59 Pickup (right hand)

P5559-16320-RRP each49.95



LOWER DOOR HINGE BRACKET

Fits inside of door.

1955-59 Chevy Pickup (left hand)

P5559-16320-DL each49.95

1955-59 Chevy Pickup (right hand)

P5559-16320-DR each49.95



DOOR HINGE REBUILDING KIT

Oversized pin & bushings, req. 2 per door.

1947-55 Pickup

P4755-16320-RK each5.95

1955-59 Pickup

P5559-16320-RK set29.95



DOOR HINGE SPRINGS

1947-54 Pickup

P4754-16323-AS pair4.95



DOOR HINGE SPRING

Require 2 per door.

1955-59 Pickup

P5559-16323-A each1.95



DOOR HINGE SIDE PIN BUSHING

(nylon)

1955-67 All

1973-78 Ser 10-30, Blazer, Jimmy

1979-84 Ser 10-30

1973-74 Ser 10-30, Blazer, Jimmy-tailgate hinge bushing

P5567-16323-BSH each95



UPPER DOOR HINGE PIN

1969-72 Ser 10-30 & Blazer

P6972-16323-A each4.95



REAR DOOR HINGE GROMMETS

1947-54 Panel Truck

P4754-16325-PHG set27.95



DOOR HINGE BOLT

Upper hinge and upper and lower to body hinge pillar bolt.

1947-55 All (1st Series)

P4755-16325-A each1.95



CARGO DOOR HINGE GROMMET SET

(4 pc set)

1960-72 Suburban

P6072-16325-AS set.59.95



REAR HATCH HINGE GROMMET

Double wall shell.

1969-72 Blazer

P6972-16325-DW pair29.95



REAR HATCH HINGE COVER GASKET

Single wall shell.

1969-72 Blazer

P6972-16325-SW pair6.95



EXTERIOR DOOR LOCK CYLINDER AND KEYS SET

Complete with 2 keys. does one side only.

1947-51 Pickup

P4751-16328-A each36.95

1952-55 1st Ser. Pickup, Panel, and Suburban

P5254-16328-A each39.95

1955-59 Pickup, Panel, and Suburban

P5559-16328-A each39.95

1960-66 Pickup

P6066-16328-A each39.95

1967-68 Chevy

P6768-16328-AS pair29.95

1967-72 Chevy

P6772-16328-AS pair19.95



MATCHING OUTSIDE DOOR LOCK BUTTON AND CYLINDER ASSEMBLIES

With keys

1952 54 Pickup

P5254-16328-PR pair89.95

1955-59 Pickup

P5559-16328-PR pair89.95

1960-66 Pickup

P6066-16328-PR pair89.95



LOCK CYLINDER TUMBLER SPRING RETAINER

1973-78 All, Blazer, Jimmy

1979-80 (2wd, 4wd, Ser. 10-30)

(spring type)

P7380-16328-B each4.95

1973-78 All, Blazer, Jimmy

1979-84 (2wd, 4wd, Ser. 10-30)

(bar type)

P7384-16328-A each8.95

check us out at www.classicchevroletparts.com

DOORS, MIRRORS, WINDSHIELD, INTERIOR PARTS



DOOR LATCH SCREWS

- 1947-51 Pickup
- P4751-16330-A set**2.95
- 1952-59 Pickup
- P5259-16330-A set**2.95
- 1960-72 Pickup
- 1960-72 Pickup
- P6072-16330-A set**4.95



1947-51 1960-63 1967-72



1955-59 1964-66 1952-55

DOOR LATCH ASSEMBLY

- 1947-51 Chevy (left hand)
- P4751-16330-LDL each**39.95
- 1947-51 Chevy (right hand)
- P4751-16330-RDL each**39.95
- 1952-55 Pickup (left hand)
- P5255-16330-LDL each**39.95
- 1952-55 (1st Series) Pickup (right hand)
- P5255-16330-RDL each**39.95
- 1955-59 Pickup (left hand)
- P5559-16330-LDL each**36.95
- 1955-59 door latch, panel rear door
- 1955-59 Panel Truck (left hand)
- P5559-16330-PDL each**44.95
- 1955-59 Pickup (right hand)
- P5559-16330-RDL each**36.95
- 1960-63 Chevy/GMC Pickup (left hand)
- P6063-16330-LSL each**79.95
- 1960-63 Chevy/GMC Pickup (right hand)
- P6063-16330-RSL each**79.95
- 1960-63 Chevy PU (right hand)
- P6366-16330-RDL each**79.95
- 1964-66 Pickup, GMC, Suburban (left hand)
- P6466-16330-LSL each**79.95
- 1964-66 Chevy GMC Suburban (right hand)
- P6466-16330-RSL each**79.95
- 1967-72 Ser 10-30
- 1969-72 Blazer (left hand)
- P6772-16330-LSL each**49.95
- 1967-72 Ser 10-30 (right hand)
- P6772-16330-RSL each**49.95
- 1973-78 (2wd, 4wd, C10-30, Blazer, Jimmy)
- 1979-81 (2wd, 4wd, C10-30) (left hand)
- P7381-16330-LH each**199.95
- 1973-78 (2wd, 4wd, C10-30, Blazer, Jimmy)
- 1979-81 (2wd, 4wd, C10-30) (right hand)
- P7381-16330-RH each**199.95



DOOR LATCH CONTROL & LINK

- Fits inside door. Connects door latch to door handle.
- 1947-55 (1st Series) Pickup (left hand)
- P4755-16330-LH each**19.95
- 1947-55 (1st Series) Pickup (right hand)
- P4755-16330-RH each**19.95
- 1955-59 Pickup (left hand)
- P5559-16330-LH each**19.95
- 1955-59 Pickup (right hand)
- P5559-16330-RH each**19.95
- 1960-63 Pickup (left hand)
- P6063-16330-LH each**24.95
- 1960-63 Pickup (right hand)
- P6063-16330-RH each**24.95
- 1964-66 Pickup (left hand)
- P6466-16330-LH each**24.95
- 1964-66 Pickup (right hand)
- P6466-16330-RH each**24.95



INSIDE DOOR LATCH CONTROL

- Does not include rod.
- 1967-71 Chevy/GMC (left hand)
- P6771-16330-LH each**19.95
- 1967-71 Chevy Chevy/GMC (right hand)
- P6771-16330-RH each**19.95
- 1972 Chevy Chevy/GMC (left hand)
- P72-16330-LH each**19.95
- 1972 Chevy Chevy/GMC (right hand)
- P72-16330-RH each**19.95



DOOR PAWL

- Fits on back of door lock cylinder.
- 1967-72 Pickup (left hand)
- P6772-16330-LH each**2.95
- 1967-72 Pickup (right hand)
- P6772-16330-RH each**2.95



DOOR LOCK T-KNOB SHAFT

- (3/16" shaft)
- 1934-40 Pickup
- P3440-16335-A each**6.95
- 1941-46 Pickup
- P4146-16335-B each**9.95

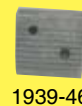

1939-46



1947-54



1955-59



1967-72



1952-55



1964-66

DOOR STRIKER PLATE

- 1939-46 Pickup (fits either side)
- P3946-16335-A each**14.95
- 1947-54 Pickup
- P4754-16335-A pair**19.95
- 1952-55 Pickup (left hand)
- P5255-16335-L each**19.95
- 1952-55 Pickup (right hand)
- P5255-16335-R each**19.95
- 1955-59 Pickup (left hand)
- P5559-16335-LDS each**19.95
- 1955-59 Pickup (right hand)
- P5559-16335-RDS each**19.95
- 1964-66 Pickup (left hand)
- P6466-16335-L each**18.95
- 1964-66 Pickup (right hand)
- P6466-16335-R each**18.95
- 1967-72 Pickup (left hand)
- P6772-16335-L each**24.95
- 1967-72 Pickup (right hand)
- P6772-16335-R each**24.95
- 1973-78 (2wd, 4wd, Ser. 10-30, Blazer, Jimmy)
- 1979-84 (2wd, 4wd, Ser. 10-30) (front or rear)
- P7384-16335-D each**9.95



DOOR STRIKER SCREWS

- 1947-51 Pickup (req. 2 per veh.)
- P4751-16335-S set**3.95
- 1952-59 Pickup (does 2 strikers)
- P5259-16335-S set**4.95



DOOR LOCK REMOTE CONTROL

- 1977-78 (2wd, 4wd, Ser. 10-30, Blazer, Jimmy)
- 1979-80 (2wd, 4wd, Ser. 10-30) (left hand)
- P7780-16341-LH each**34.95
- 1977-78 (2wd, 4wd, Ser. 10-30, Blazer, Jimmy)
- 1979-80 (2wd, 4wd, Ser. 10-30) (right hand)
- P7780-16341-RH each**31.95



Birthday coming up?

Ask for a Classic Chevrolet Parts gift certificate!



DOORS, MIRRORS, WINDSHIELD, INTERIOR PARTS

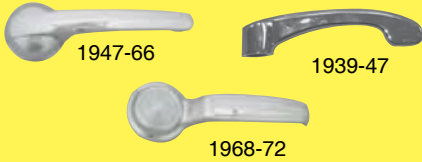

INSIDE DOOR HANDLE

- 1939-47 Chevy Pickup
P3947-16345-A each39.95
- 1947-66 Pickup
P4754-16345-A each12.95
- 1967 All
P67-16345-A each19.95
- 1968-72 All
P6872-16345-A each5.95



DOOR & WINDOW CRANK HANDLE RETAINING CLIP

- All
B-16166-CL each95



DOOR HANDLE SPRING

- Eliminates drooping handle. Fits on door latch.
1947-51 Pickup
P4751-16345-A each7.95



INSIDE DOOR HANDLE GASKET SET

- 8 pcs: 4 sponge & 4 fiber washers.
1947-54 Pickup
P4754-16345-AS pair4.95
- 1955-59 Pickup
P5559-16345-AS set.3.95



INSIDE DOOR HANDLE SCREW

- 1947-59 Pickup
P4754-16345-MB each95



DOOR LOCK REMOTE CONTROL ROD CLIP

- 1973-76 Ser 10-30, Blazer, Jimmy
P7376-16345-CL each4.95



INSIDE DOOR HANDLE CUP

- Black, dye to match.
1977-80 Pickup
P7780-16345-CUP pair.14.95



1947-51

1952-59

NEW!



1960-66

1967-72

EXTERIOR DOOR HANDLES

- Chrome plated, complete with all hardware and gaskets.
1947-51 Truck
P4751-16350-PR pair59.95
- 1952-59 Pickup
P5259-16350-AS pair59.95
- 1960-66 Pickup
P6066-16350-AS pair59.95
- 1967-72 Chevy/GMC All
P6772-16350-PR pair59.95
- 1973-78 (2wd, 4wd, Ser. 10-30, Blazer, Jimmy) left hand, with black knob
P7378-16350-LH each29.95
- 1973-78 (2wd, 4wd, Ser. 10-30, Blazer, Jimmy) right hand, with black button
P7378-16350-RH each29.95



EXTERIOR DOOR HANDLE FERRULE

- Includes stainless ring & rubber ferrule. (req. 2)
1938-46 Pickup
P3846-16353-DF each9.95



OUTSIDE DOOR HANDLE & LOCK GASKETS

- 1942-46 Pickup
P4246-16353-DLG each95
- 1942-51 Pickup
P4751-16353-AS set.3.95
- 1952-66 Pickup
P5254-16353-AS pair1.95
- 1967-72 Pickup
P6772-16353-AS set.2.95



OUTSIDE DOOR HANDLE GASKET

- Cut to fit either side of handle
1973-78 (2wd, 4wd, Ser. 10-30, Blazer, Jimmy)
1979-84 (2wd, 4wd, Ser. 10-30) (left hand)
P7384-16353-LH each5.95
- 1973-78 (2wd, 4wd, Ser. 10-30, Blazer, Jimmy)
1979-84 (2wd, 4wd, Ser. 10-30) (right hand)
P7384-16353-RH each5.95



HANDLE SCRATCH SHIELDS

- Stainless steel
1952-59 Pickup
P5559-16353-SSH pair.19.95



DOOR LOCK SHIMS

- 1947-59 Pickup
P4754-16385-AS pair5.95



ROUND DOOR BUMPER

- 1930-46 Pickup
P3046-16400-A each1.95



DOOR STRAP CHECK BRACKET

This is made of thicker steel than original. Made to last!

1939-46 Chevy-GMC

P3946-16400-CB each24.95



DOOR BUMPER SET

Does both doors.

1936-46 Pickup

P3646-16400-K kit10.95

1947-51 Pickup

P4751-16400-AS set.3.95

1952-55 Pickup

P5255-16400-AS set.1.95

1955-59 Pickup

P5559-16400-AS set.4.95

1960-63 Pickup

P6063-16400-AS set.4.95

1967-72 Pickup

P6772-16400-AS set.7.95



FRONT SIDE DOOR BUMPER

(on pillar) - req. 4

1960-65 All

1979-84 (2wd, 4wd, Ser. 10-30 (front or rear)

P6072-16400-BM each1.95



REAR DOOR BUMPERS

Requires 4.

1967-72 Ser 10-20 (Panel, Suburban)

1973-78 (2wd, 4wd, Suburban, w/ Panel doors)

1979-84 (2wd, 4wd, Ser 10-20, Suburban (exc end gate)

P6772-16400-BM each3.95

Here's Cindy, hard at work in the office.... Service with a smile!



DOOR "HOLD OPEN" BRACKETS

(w/rubber block, pin & tension spring) Does one door.

1939-46 Pickup

P3946-16400-BRK set26.95



DOOR CHECK RETAINER

1960-66 Pickup

P6066-16437-A each12.95

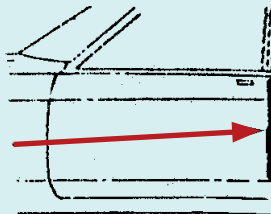

DOOR EDGE GUARDS

Stamped from stainless steel and formed to fit and remain on the door edge contour without screws or cement, the guards protect paint and prevent nicks and chips.

1967-72 Pickup

P6772-16445-AB pair.44.95

1973-78 (2wd, 4wd, Ser. 10-30, Blazer, Jimmy)

1979-83 (2wd, 4wd, Ser. 10-30)

(left hand), steel

P7383-16445-LH each9.95

1973-78 (2wd, 4wd, Ser. 10-30, Blazer, Jimmy)

1979-83 (2wd, 4wd, Ser. 10-30)

(right hand), steel

P7383-16445-RH each9.95

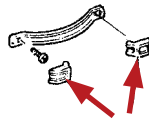

FRONT DOOR ASSIST STRAP COVER

1977-80 (Ser. 10-30, Blazer, Jimmy)

1979-80 (Ser. 10-30)

P7780-16450-A each12.95

FRONT DOOR ASSIST STRAP BRACKET

1977-78 (2wd, 4wd, Ser. 10-30, Blazer, Jimmy)

1979-84 (2wd, 4wd, Ser. 10-30)

(left hand)

P7784-16450-LH each14.95

1977-78 (2wd, 4wd, Ser. 10-30, Blazer, Jimmy)

1979-84 (2wd, 4wd, Ser. 10-30)

(right hand)

P7784-16450-RH each14.95

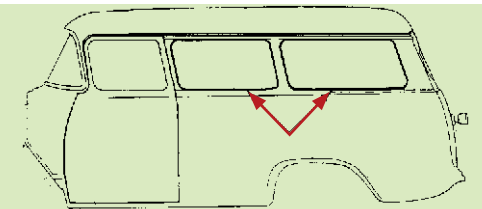

SUBURBAN SIDE WINDOW GASKET

Requires 2 per vehicle.

1955-66 Suburban (with stationary side windows)

P5566-16460-A each29.95

1955-66 Suburban (with sliding side windows)

P5566-16460-B each49.95

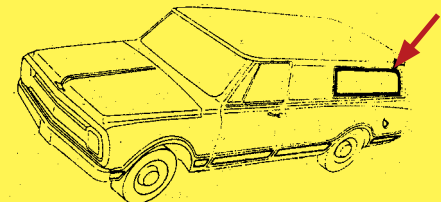

REAR QUARTER WINDOW GASKETS

1967-72 Suburban

P6772-16460-A pair189.95

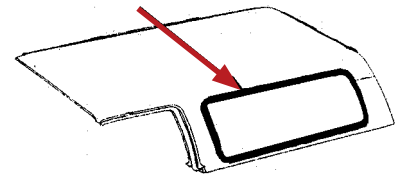

STATIONARY SIDE WINDOW GASKET

Double-wall top, fits either side.

1969-72 Blazer

P6972-16460-A each59.95

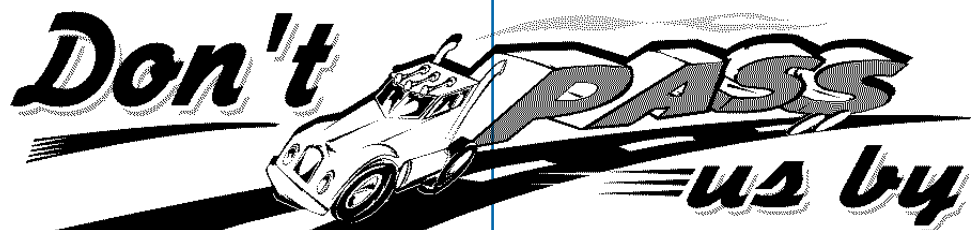



DOORS, MIRRORS, WINDSHIELD, INTERIOR PARTS

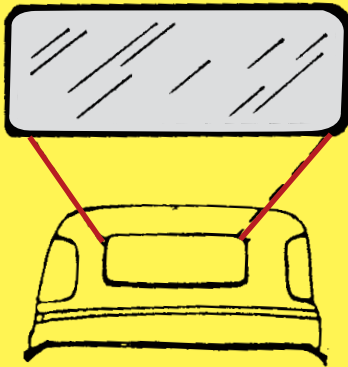

REAR WINDOW GLASS

Cut to exact specs, clear glass (tinted also available, call for quote)

- 1932 Pickup
- P32-16464-A each99.95**
- 1933 Pickup
- P33-16464-A each99.95**
- 1934 Pickup
- P34-16464-A each99.95**
- 1935 Pickup
- P35-16464-A each99.95**
- 1936 Pickup
- P36-16464-A each99.95**
- 1936 Pickup (2nd series w/ low roof, peanut shaped corners on windshield)
- P36-16464-B each99.95**
- 1937-38 Pickup
- P3738-16464-A each99.95**
- 1939 Pickup
- P39-16464-A each99.95**
- 1940 Pickup
- P40-16464-A each99.95**
- 1947-54 Pickup
- P4750-16464-A each99.95**
- 1955-59 Chevy and GMC (clear)
- P5559-16464-A each54.95**
- 1955-59 Chevy and GMC (tinted)
- P5559-16464-AG each69.95**
- 1955-59 Chevy and GMC (clear)
- P5559-16464-WC each214.95**
- 1955-59 Pickup (green tint as original)
- P5559-16464-WG each299.95**
- 1960-66 Pickup (w/ standard small window)
- P6063-16464-A each129.95**
- 1960-66 Pickup (w/ deluxe large window)
- P6063-16464-B each129.95**
- 1967-72 Pickup (w/ standard small window)
- P6772-16464-A each129.95**
- 1967-72 Pickup (w/ deluxe large window)
- P6772-16464-B each129.95**



REAR CAB CORNER GLASS

- 1947-54 Chevy/GMC Pickup (Left hand, clear glass)
- P4754-16464-CL each49.95**
- 1947-54 Chevy/GMC Pickup (Right hand, clear glass)
- P4754-16464-CR each49.95**
- 1947-54 Chevy/GMC (Left hand, light green tint)
- P4754-16464-TL each54.95**
- 1947-54 Chevy/GMC Pickup (Right hand, tinted quarter glass)
- P4754-16464-TR each54.95**



SLIDING BACK WINDOW LATCH

- 1973-83 Pickup
- P7383-16464-A each26.95**

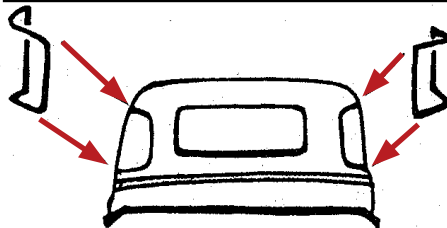

CORNER GLASS RUBBER KIT

- 1947-55 Pickup (with black filler strip)
- P4755-16469-A pair19.95**
- 1947-55 Pickup (with chrome filler strip)
- P4755-16469-B kit29.95**



LOCK BEAD INSTALLATION TOOL

Special tool designed to assist in installing window gasket locking bead.

- All
- B-16471-TL each14.95**



REAR WINDOW BEAD

- 1955-59 Pickup (Large)
- P5559-16471-LCB each15.95**
- 1955-59 Pickup (Small)
- P5559-16471-SCB each12.95**

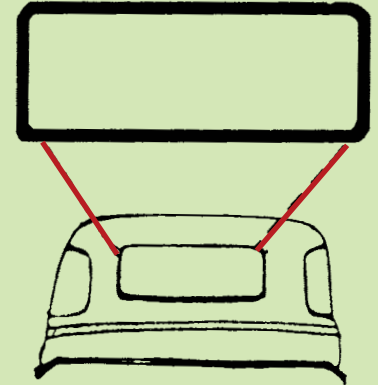

REAR WINDOW RUBBER

- Molded exactly like original.
- 1936-41 Chevy/GMC Pickup
- 1936-41 Chevy/GMC Pickup
- P3641-16470-A each24.95**
- 1942-66 Pickup (Standard)
- P4266-16470-A each19.95**
- 1955-61 Pickup (std large back window)
- PU5566-16470-A each34.95**
- 1967 Pickup (std small back window)
- PU67-16470-A each29.95**
- 1968-72 Pickup (std large back window)
- PU6872-16470-A each32.95**
- 1968-72 (Dlx large window w/ groove for outer chrome moulding)
- PU6872-16470-B each34.95**
- 1973-91 (Std. No outer chrome moulding on window)
- PU7391-16470-A each39.95**
- 1947-54 Panel Truck (rear doors)
- P4754-16470-B set34.95**
- 1942-66 Pickup (deluxe small back glass)
- P4266-16470-B each22.95**
- 1955-66 Pickup (deluxe large back glass, with chrome filler strip)
- P5566-16470-B each39.95**
- 1960-66 Panel (Rear Doors)
- P6066-16470-AS pair34.95**

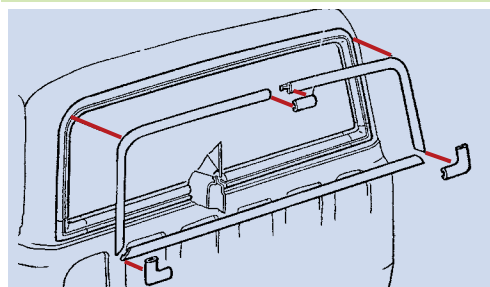

REAR WINDOW STAINLESS TRIM

- Inserts into rubber gasket, (6 pc. set)
- 1968-72 Chevy
- P6872-16471-S set59.95**

Please allow 2-4 weeks for delivery on most special order items.

We appreciate your business!



NEW!



CUSTOM SCRIPT CAB SIDE MOULDINGS

1960-63 Chevy Pickup with custom cab
P6063-16475-A Pair219.95



BACK WINDOW REVEAL CAP

1973-84 (2wd, 4wd, Ser. 10-30 (cab, exc rear sliding glass))
P7384-16475-C each7.95

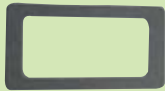

DOMELIGHT LENS GASKET

1947-54 Pickup
P4754-16494-G each95



DOMELAMP HOUSING

1973-83 Cab (2-door)
P7383-16494-B each7.95
 1973-78 Blazer
P7384-16494-A each6.95



DOMELAMP SWITCH

On door jamb.
 1973-78 Ser 10-30, Blazer, Jimmy
 1979-84 Ser 10-30
P7378-16494-SW each6.95



1955-59



1960-72



1973-78

DOMELAMP LENS

Original pattern
 1955-59 Pickup
P5559-16495-A each6.95
 1960-72 Pickup
P6066-16495-A each1.95
 1973-78 All
P7384-16495-A each1.95



1947-55



1955-72



1960-72

DOMELAMP ASSEMBLY

1947-55 Pickup
 w/painted base (includes base, lens, wiring and 6 & 12v bulbs)
P4755-16494-AS each49.95
 1947-55 Truck
 Chrome complete includes 6v & 12v bulb
P4755-16494-CH59.95
 1955-59 Pickup
 (plastic chrome with original lens & wiring)
P5559-16494-AS each24.95
 1955-72 Pickup
 White
P5559-16494-WA each.9.95
 1960-72 Pickup
 w/ chrome base (includes base, lens) Does not include wiring.
P6072-16494-AS each10.95
 1968-70 Ser 10-20 (Panel, Suburban)
 (white base, has wires)
P6870-16494-A each14.95



DOMELAMP HOUSING SPACER

1973-84 (2wd, 4wd, Ser. 10-30 (cab))
P7384-16494-S each4.95



DOMELAMP BULB CLIP

(req. 2)
 1960-68 All
P6068-16495-WC each.95

DOMELIGHT BULB

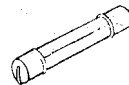

1967-72 Pickup
P6772-16495-A each2.95

CAB FLOOR WITH 8 INCH TOEBOARD



Die stamped steel
 1947-54 Chevy/GMC Pickup (left hand)
P4754-16545-LH each69.95
 1947-54 Chevy/GMC Pickup (right hand)
P4754-16545-RH each69.95



NEW!

1947-54



1955-59

COMPLETE ONE PIECE FLOOR PAN, DIE STAMPED STEEL

Transmission and battery cover sold separately.
 1947-54 Chevy/GMC Pickup. Also fits 1955 1st Ser.

P4754-16545-100 each.479.95
 1955-59 Chevy/GMC Pickup (Complete with all braces and cutouts)
P5559-16545-100 each.629.95



CENTER CAB FLOOR PAN

Goes from bottom of firewall to rear of cab.
 Center piece only.

1955-59 Pickup
P5559-16545-CFP each149.95



INNER COWL KICK PANEL

Stamped steel
 1955-59 Pickup (left hand)
P5559-16545-CL each29.95
 1955-59 Pickup (right hand)
P5559-16545-CR each29.95



DOORS, MIRRORS, WINDSHIELD, INTERIOR PARTS

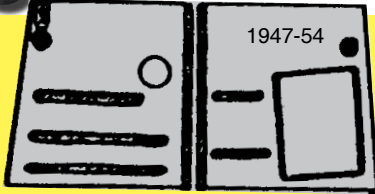

1947-54

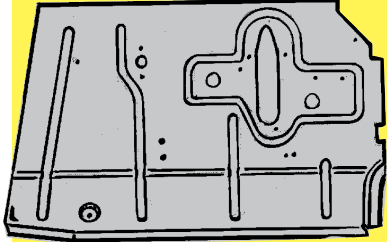

1955-59, left hand



1960-66



1967-72



1973-85

STEEL FRONT SECTION FLOOR PAN

- 1947-54 Pickup (right hand)
P4754-16545-A each69.95
- 1947-54 Pickup (left hand)
P4754-16545-B each69.95
- 1955-59 Pickup (right hand, with toe panel)
P5559-16545-FA each99.95
- 1955-59 Pickup (left hand, with toe panel)
P5559-16545-FB each99.95
- 1960-66 Pickup (right hand, 27"l x 25"w)
P6066-16545-FA each39.95
- 1960-66 Pickup (left hand, 27"l x 25"w)
P6066-16545-FB each39.95
- 1967-72 Pickup (right hand, 27"l x 27"w)
P6772-16545-FA each39.95
- 1967-72 Pickup (left hand, 27"l x 27"w)
P6772-16545-FB each39.95
- 1973-85 Pickup (left hand)
P7385-16545-CFPL each39.95
- 1973-85 Pickup (right hand)
P7385-16545-CFPR each39.95

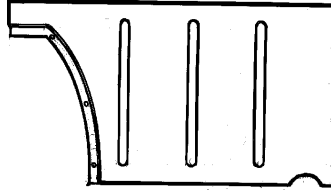

FRONT FLOOR LOWER SECTION

- Die-stamped steel
- 1955-59 Pickup (left hand)
P5559-16545-LL each59.95
- 1955-59 Pickup (right hand)
P5559-16545-LR each59.95



CAB FLOOR OUTER REAR SECTION

- 1960-72 Pickup (right hand, 28"l x 9"h)
P6066-16545-RA each34.95
- 1960-72 Pickup (left hand, 28"l x 9"h)
P6066-16545-RB each34.95



TRANSMISSION COVER

- Exact metal reproduction. (3 spd trans. only)
- 1947-54 Pickup
P4755-16547-A each49.95
- 1955-59 Pickup
P5559-16547-A each79.95



TRANSMISSION COVER MOUNTING SCREWS

- 1947-55 Pickup (11 pc. kit)
P4755-16547-MB set3.95
- 1955-59 Pickup (9 pc. set)
P5559-16547-MB set3.95

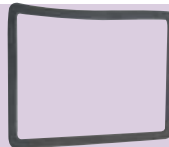

BATTERY HOLE INSPECTION COVER SEAL

- Rubber
- 1947-55 Pickup
P4755-16547-RS each4.95



FLOOR PANEL PLUG

- Vacuum power brake air cleaner hole plug.
- 1960-64 All
P6064-16547-PL each95



TRANSMISSION COVER GASKET SET

- (4 pc. set)
- 1947-55 Pickup
P4755-16549-G set7.95

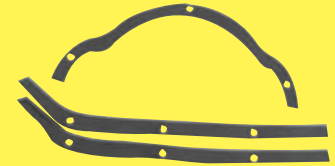

TRANSMISSION COVER FLOOR GASKET

- 1955-59 Chevy Pickup
P5559-16549-G set4.95

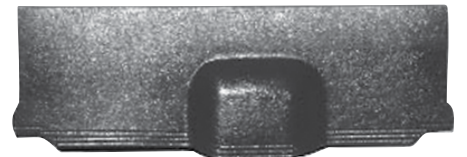

OEM STYLE FIREWALLS

- OEM style with padding on the backside. These are made from ABS black plastic with a medium embossed leather grain. This is vacuum formed to match your firewall. Instructions included.
- 1937-46 Pickup
P3746-16550-QR set159.95
- 1947-54 Pickup
P4754-16550-QR each159.95
- 1955-59 Pickup
P5559-16550-QR set159.95
- 1960-63 Pickup
P6063-16550-QR set159.95
- 1964-66 Pickup
P6466-16550-QR set159.95
- 1967-72 Pickup
P6772-16550-QR set159.95
- 1973-79 Pickup
P7379-16550-QR set159.95
- 1980-86 Pickup
P8086-16550-QR set159.95

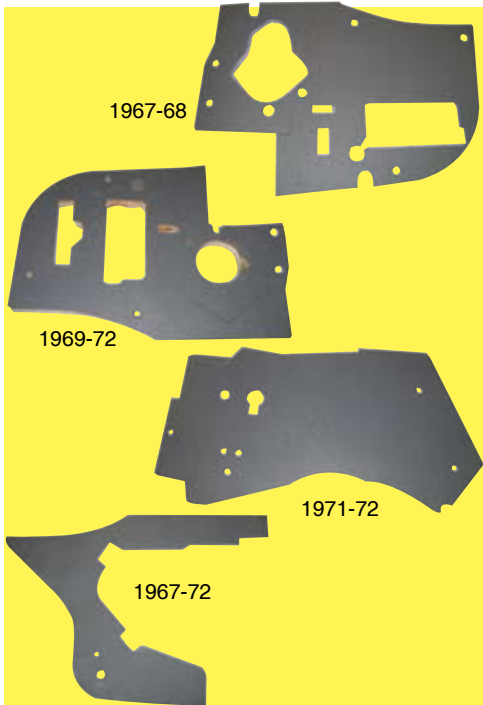

FIREWALL COVER

Die stamped with pad, like original. Fits on inside of firewall, under dash.

- 1960-66 Pickup (2 pieces) **P6066-16550-PI set**56.95
- 1967-70 Pickup (Center) **P6770-16550-CAS each**29.95
- 1967-72 Pickup (w/ out AC) (Right hand) **P6772-16550-RBS each**14.95
- 1967-68 Pickup (Left hand) **P6768-16550-LAS each**29.95
- 1969-72 Pickup (Left hand) **P6972-16550-LAS each**29.95
- 1971-72 Pickup (Center) **P7172-16550-CAS each**29.95

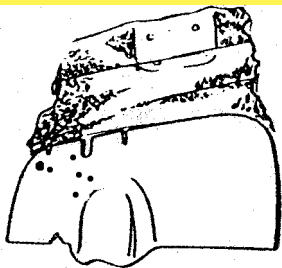

FIREWALL INSULATION PAD SET

This is the pad that goes under firewall cover. 1947-54 Pickup

- P4754-16550-IP set**19.95
- 1960-66 Pickup (2 pieces) **P6066-16550-PI set**56.95



NEW!

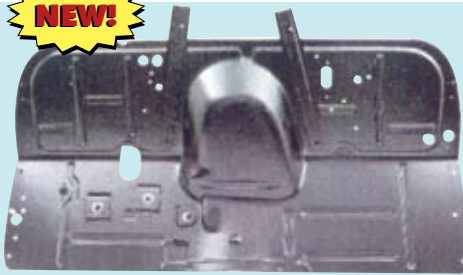

COMPLETE FIREWALL ASSEMBLY

Holes punched and reinforcement stamped as original. 1947-54 Chevy/GMC Pickup, also fits 1955 1st Ser.

P4754-16550-100 each289.95

NEW!



COMPLETE COWL PANEL, DIE STAMPED STEEL

1947-53 Chevy, GMC

P4754-16550-TOP each299.95

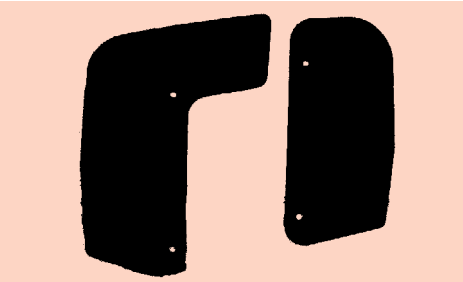

FIREWALL TO FENDER FILLER PANELS

1947-55 Pickup

P4755-16550-FP pair12.95



NEW!

OUTER CAB COWL PANEL, DIE STAMPED STEEL

Black primered

1947-55 1st Chevy Pickup (left hand)

P4755-16550-LH each139.95

1947-55 1st Chevy Pickup (right hand)

P4755-16550-RH each139.95

NEW!



UPPER FLOOR BOARD SECTION

Die stamped steel. Tapered metal panel between firewall & floorboard. 13 1/2" x 53 1/2" with proper bends and ridges.

1947-55 Pickup (1st Series, below firewall)

P4755-16550-TB each219.95



FIREWALL PAD FASTENER SET

Set of 12, replacement type.

1955-72 Pickup

P5572-16550-MB kit6.95



FIREWALL PAD FASTENER TOOL

This is the tool that installs P5572-16550-MB.

1955-72 Pickup

P5572-16550-TL each12.95



NEW!

CAB FRONT DOOR PILLER OUTER REPAIR PANEL

1967-72 Chevy/GMC all body styles (left hand)

P6772-16550-OPL each19.95

1967-72 Chevy/GMC all body styles (right hand)

P6772-16550-OPR each19.95

Don't pass us by!
Stop in and check us out!
8723 South Interstate 35
Oklahoma City, OK





DOORS, MIRRORS, WINDSHIELD, INTERIOR PARTS



FRONT COWL REPAIR PANEL

- 1947-55 Pickup (left hand)
P4755-16551-LH each39.95
- 1947-55 Pickup (right hand)
P4755-16551-RH each39.95

INNER TO OUTER COWL PANEL

- Perfectly replaces the area that usually rusts out behind front wheel. Welds to inner and outer cowl panels.
- 1947-55 Pickup (left hand) **NEW!**
P4755-16551-IOL each64.95
 - 1947-55 Pickup (right hand) **NEW!**
P4755-16551-IOR each64.95



INSIDE FIREWALL COVER CLIP KIT

- 10 pieces
- 1947-59 Pickup
P4759-16551-CL kit6.95



1967-72



1947-55

INNER COWL RUST REPAIR KICK PANEL

- Steel reproduction
- 1947-50 Pickup (Left hand, with louvers)
P4750-16551-IL each39.95
 - 1947-55 Pickup (Right hand, with louvers)
P4755-16551-IR each39.95
 - 1951-55 Pickup (Left hand, with louvers)
P5155-16551-IL each39.95
 - 1967-72 Chevy Pickup (Left hand)
P6772-16551-IL each26.95
 - 1967-72 Chevy Pickup (Right hand)
P6772-16551-IR each26.95



Special order

BLAZER REAR INNER SIDE INTERIOR TRIM PANELS

- 1969-72 Blazer (Black)
P6972-16575-BLK pair499.95
- 1969-72 Blazer (Blue)
P6972-16575-BL pair499.95
- 1969-72 Blazer (Green)
P6972-16575-GR pair499.95
- 1969-72 Blazer (Red)
P6972-16575-RD pair499.95
- 1969-72 Blazer (Saddle)
P6972-16575-SD pair499.95
- 1969-72 Blazer (White)
P6972-16575-WH pair499.95



NEW! Outer



NEW! Inner

REAR CAB PANEL FOR FIVE WINDOW DELUXE CAB

- Great for converting 3 window to a 5 window cab. Die stamped steel.
- 1947-53 Chevy/GMC Pickups (Outer)
P4753-16585-5W each399.95
 - 1947-53 Chevy/GMC Pickup (Inner)
P4753-16589-5W each249.95



1947-53



1955-59

EXTERIOR STEEL SUNVISOR

- Adjustable to fit many models from 30 to early 50s. Reproduction of the fulton accessory visor.
- 1947-53 Chevy/GMC Pickup
P4753-16585-VA each449.95
 - 1955-59 Pickup
P5559-16585-VA each149.95



DOUBLE WALL ROOF RAIL SEAL

- Seals door glass to top.
- 1969-71 Blazer (left hand)
P6971-16585-LH each59.95
 - 1969-71 Blazer (right hand)
P6971-16585-RH each59.95



HATCH TO GLASS SEAL

- 1967-72 Suburban
P6772-16585-LG each79.95



DRIP DEFLECTOR SEAL

- Fits camper shell at front corners.
- 1969-72 Blazer
P6972-16585-DDS each29.95

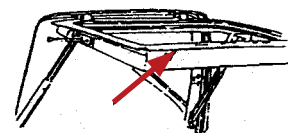

WINDOW LIFT GATE SEAL

- 1969-72 Blazer (Seals gate to top)
P6972-16585-LGW each44.95
- 1976-91 Blazer
Fits in top, complete with molded ends and all clips installed.
P7691-16585-A each99.95



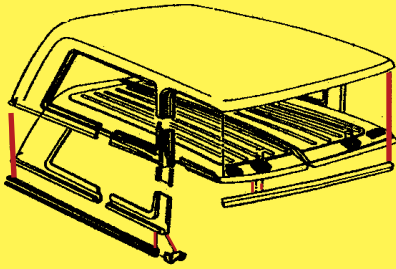

TOP TO BED SEALS

- 1969-72 Blazer (double wall top)
P6972-16585-PR pair79.95
 1969-72 Blazer (left hand, single wall top)
P6972-16585-SLH each29.95
 1969-72 Blazer (right hand, single wall top)
P6972-16585-SRH each29.95
 1973-75 Blazer
P7375-16585-BS pair109.95

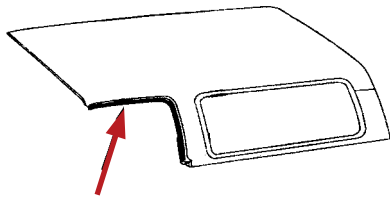

BLAZER ROOF-RAIL SEALS

- Single wall top (fits in metal channel)
 1969-72 Blazer
P6972-16585-SW each129.95
 1973-75 Blazer/Jimmy
P7375-16585-RF pair69.95

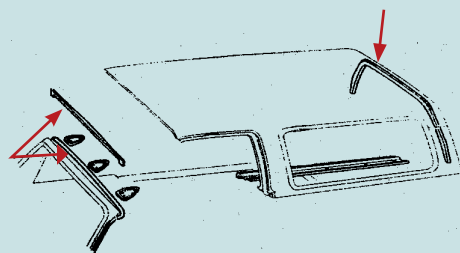

BLAZER/JIMMY TOP WEATHERSTRIP ASSEMBLY

- Mounts on windshield
 1973-75 Blazer/Jimmy (inner)
 Mounts on shell
P7375-16585-I each99.95
 1973-75 Blazer/Jimmy (outer)
 Mounts on shell
P7375-16585-O each99.95
 1976-82 Blazer/Jimmy
 Mounts on shell
P7682-16585-O each29.95
 1976-78 Blazer, Jimmy (2 door cab) with removable top
 1979-82 All (w/ 106.5 W.B. and 131.5 W.B.)
 Blazer, Jimmy (2 door cab) with removable top
 Removeable/soft folding or hard top front inner weatherstrip assembly, on cab.
P7682-16585-A each59.95

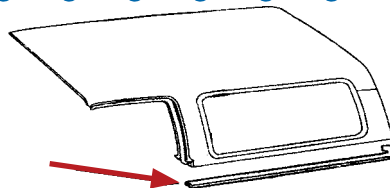

ROOF SIDE LOWER WEATHERSTRIP

- Removeable/soft folding or hard top.
 1976-78 Blazer, Jimmy
 1979-82 All (CK-1, w/ 106.5 W.B. and 131.5 W.B.) Blazer, Jimmy
 (left hand)
P7682-16585-LH each69.95
 1976-78 Blazer, Jimmy
 1979-82 All (CK-1, w/ 106.5 W.B. and 131.5 W.B. (Blazer, Jimmy 2 door cab)
 (right hand)
P7682-16585-RH each69.95



CAB REAR OUTER PANEL

- Repairs all rusted areas from door to door, bottom to approx 36 inches high, must ship truck lines. This is the complete lower back of cab panel.
 1947-54 Chevy/GMC Pickup. will also fit 1955 1st ser.
P4754-16587-100 each379.95



1947-55

INNER CAB CORNER

- 1947-55 First Chevy GMC Pickup (left hand)
P4754-16587-ILCC each34.95
 1947-55 First Chevy GMC (right hand)
P4754-16587-IRCC each34.95
 1947-55 Chevy Pickup (left hand)
P5559-16587-ILCC each89.95
 1947-55 Chevy Pickup (right hand)
P5559-16587-IRCC each89.95
 1973-87 Pickup (left hand)
P7387-16587-IL each29.95
 1973-87 Pickup (right hand)
P7387-16587-IR each29.95

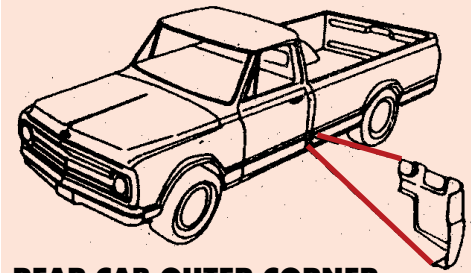

REAR CAB OUTER CORNER REPLACEMENT PANEL

- **Make note of year fit** Die stamped steel.
 1947-54 Chevy Pickup (left hand)
P4654-16587-LCC each29.95
 1947-54 Chevy Pickup (right hand)
P4654-16587-RCC each29.95
 1955-59 Chevy Pickup (left hand)
P5559-16587-LCC each29.95
 1955-59 Chevy Pickup (right hand)
P5559-16587-RCC each29.95
 1960-66 Chevy Pickup (left hand)
P6066-16587-LCC each19.95
 1960-66 Chevy Pickup (right hand)
P6066-16587-RCC each19.95
 1967-72 Chevy Pickup (left hand)
P6772-16587-LCC each19.95
 1967-72 Chevy Pickup (right hand)
P6772-16587-RCC each19.95
 1973 85 Chevy Pickup (left hand)
P7385-16587-LCC each19.95
 1973 85 Chevy Pickup (right hand)
P7385-16587-RCC each19.95

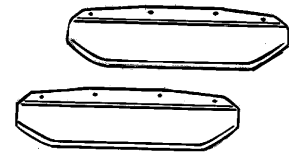

REAR CAB ROCK DEFLECTORS

- Attaches to lower edge cab corners.
 1955-59 Pickup
P5559-16587-RD each27.95
 1960-66 Pickup
P6066-16587-RD each39.95





DOORS, MIRRORS, WINDSHIELD, INTERIOR PARTS

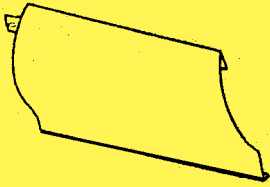

RUNNING BOARD SPLASH APRON

Formed steel, primed & ready to paint.
1934-36 Pickup (right hand)

- P3436-16600-A each** 44.95
- 1934-36 Pickup (left hand)
- P3436-16600-B each** 44.95
- 1937-39 Pickup (right hand)
- P3739-16600-A each** 44.95
- 1937-39 Pickup (left hand)
- P3739-16600-B each** 44.95
- 1940-46 Chevy/GMC Pickup (left hand)
- P4046-16600-AL each** 39.95
- 1940-46 Chevy/GMC Pickup (right hand)
- P4046-16600-AR each** 39.95
- 1940-46 Pickup (left hand)
- P4046-16600-BL each** 69.95
- 1940-46 Pickup (right hand)
- P4046-16600-BR each** 69.95
- 1947-53 Pickup (left hand)
- P4753-16600-AL each** 39.95
- 1947-53 Pickup (right hand)
- P4753-16600-AR each** 39.95
- 1947-53 (3/4 Ton) Chevy/GMC Pickup (left hand)
- P4753-16600-BL each** 54.95
- 1947-53 (3/4 Ton) Chevy/GMC Pickup (right hand)
- P4753-16600-BR each** 54.95
- 1954 Pickup (left hand)
- P54-16600-AL each** 49.95
- 1954 Pickup (right hand)
- P54-16600-AR each** 49.95
- 1954 (3/4 Ton) Chevy/GMC Pickup (left hand)
- P54-16600-BL each** 54.95
- 1954 Pickup (right hand)
- P54-16600-BR each** 54.95
- 1955-66 Chevy/GMC Stepside Pickups (left hand)
- P5566-16603-BL each** 31.95
- 1955-66 Chevy/GMC Pickups (right hand)
- P5566-16603-BR each** 31.95

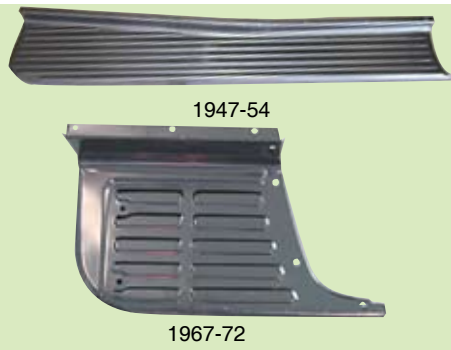

STEEL RUNNING BOARDS

Stamped steel. Exact reproductions, perfect fit.
1947-55 Chevy Pickup (1st Series)

- P4755-16603-AS pair** 499.95
- 1955-66 Short bed Pickup Chevy/GMC (left hand)
- P5566-16603-LH each** 149.95
- 1955-66 Chevy/GMC Pickup (right hand)
- P5566-16603-RH each** 149.95
- For six foot step side bed.
- 1967-72 Chevy/GMC short stepside (left hand)
- P6772-16603-LH each** 79.95
- 1967-72 Chevy/GMC short stepside (right hand)
- P6772-16603-RH each** 79.95
- Fits between the rear fender and the cab on all six foot stepside beds.
- 1973-86 Chevy GMC short stepside (left hand)
- P7386-16603-LH each** 69.95
- 1973-86 Chevy/GMC short stepside Pickup (right hand)
- P7386-16603-RH each** 69.95



Take some time to check out our website! Order your parts online or order one of our useful catalogs!

www.classicchevroletparts.com

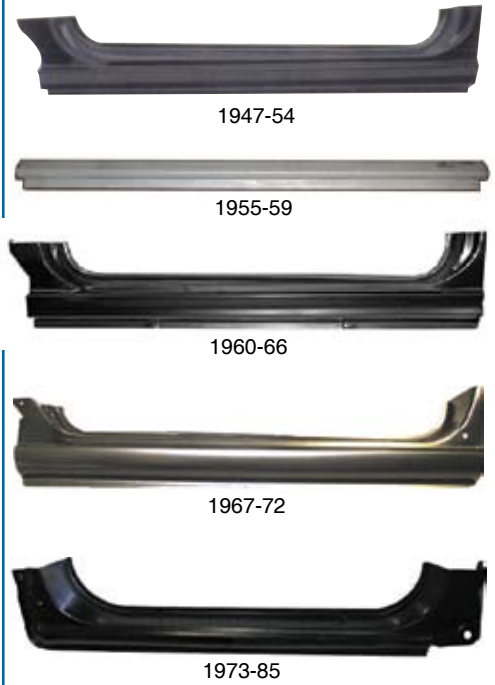

ROCKER PANEL

Fits under door between fender and bed. EDP black with correct gauge metal.

- 1947-54 Chevy 1st GMC (left hand)
- P4754-16603-LRP each** 44.95
- 1947-55 1st Chevy GMC Pickup (right hand)
- P4754-16603-RRP each** 44.95
- 1955-59 Chevy/GMC Pickup (fits either side)
- P5559-16603-RP each** 36.95
- 1960-66 Pickup & Panel (left hand)
- P6066-16603-LRP each** 49.95
- 1960-66 Pickup & Panel (right hand)
- P6066-16603-RRP each** 49.95
- 1967-72 Pickup, Suburban, Blazer, Jimmy (left hand)
- P6772-16603-LRP each** 19.95
- 1967-72 Pickup, Suburban, Blazer, Jimmy (right hand)
- P6772-16603-RRP each** 19.95
- 1973-85 Pickup, Suburban, Blazer, Jimmy (left hand)
- P7385-16603-LRP each** 29.95
- 1973-85 Pickup, Suburban, Blazer, Jimmy (right hand)
- P7385-16603-RRP each** 29.95
- 1973-87 Pickup, Blazer, Jimmy (left hand)
- 34" l x 7" h extended. Inner panel.
- P7387-16603-IL each** 12.95
- 1973-87 Pickup (right hand)
- 34" l x 7" h extended. Inner panel. **NEW!**
- P7387-16603-IR each** 12.95
- 1973-90 Blazer, Jimmy
- 1973-91 Suburban (left hand) (71" l x 5" h) **NEW!**
- P7391-16603-LRP each** 29.95
- 1973-90 Blazer, Jimmy
- 1973-91 Suburban (right hand) (71" l x 5" h)
- P7391-16603-RRP each** 29.95



DOORS, MIRRORS, WINDSHIELD, INTERIOR PARTS



INNER ROCKER PANEL BACKING PLATE

Fits either side. (req. 2)
1960-72 Chevy and GMC Pickup
P6072-16603-U each9.95

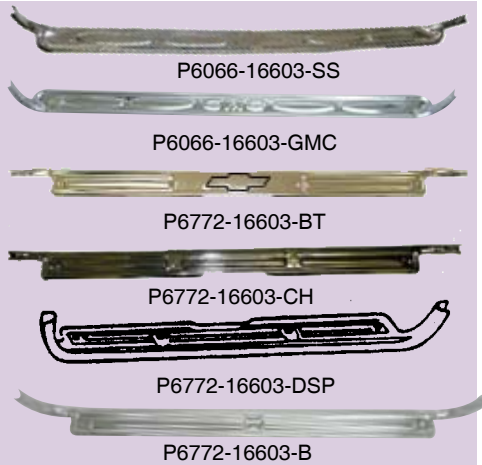

P6066-16603-SS

P6066-16603-GMC

P6772-16603-BT

P6772-16603-CH

P6772-16603-DSP

P6772-16603-B

DOOR SILL PLATE

1960-66 Chevy Pickup
Also called "door scuff plates". Exact as original, except made of stainless steel.

P6066-16603-SS each39.95
1960-66 All (cadmium plated)
Stamped with Chevy bowtie. Fits either side.

P6066-16603-DSP each39.95
1960-66 GMC Pickup (Chrome)

P6066-16603-GMC each27.95
1960-66 Chevy (GM registered)
Chrome with Chevy bowtie.

P6066-16603-CH each19.95
1967-72 Suburban (For 3rd door)

P6772-16603-B each24.95
1967-72 Chevy Pickup
Chrome with Chevy bowtie.

P6772-16603-BT each19.95
1967-72 Pickup, Blazer, Suburban (chrome)

P6772-16603-CH each16.95
1967-72 Pickup
Fits either side. Chrome plated as original.

P6772-16603-DSP each19.95
1967-72 Chevy/GMC (Polished stainless steel.)

P6772-16603-SS each19.95



DOOR SILL PLATE SCREWS

1967-72 Pickup
P6772-16603-SC set.2.95
1960-66 Pickup
P6066-16603-SC set.2.95



FRONT DOOR SILL PLATE

Also called "door scuff plates".
1973-76 (2wd, 4wd, Ser. 10-30 (cab) (left hand)
P7376-16603-LH each69.95
1973-76 (2wd, 4wd, Ser. 10-30 (cab) (right hand)

P7376-16603-RH each69.95
1973-77 Blazer, Jimmy (left hand)

P7377-16603-LH each32.95
1973-84 (2wd, 4wd, Ser. 10-30 (left hand)

P7384-16603-LH each27.95
1973-77 (2wd, 4wd, Ser. 10-30)

1978 (2wd, 4wd, Ser. 10-30 (2 or 4 door, Suburban)

1979-84 (2wd, 4wd, Ser. 10-30 (Suburban, Cab 4 door)

(right hand)
P7384-16603-RH each27.95

1973-84 (2wd, 4wd, Ser. 10-30 (cab 4 door, Suburban)

Front door sill, left rear section
P7384-16603-RLH each44.95

1973-84 (2wd, 4wd, Ser. 10-30 (Cab 4 door, Suburban)

Front door sill, right rear section
P7384-16603-RRH each24.95

1973-82 (2wd, 4wd, Ser. 10-20, Suburban)
For rear door

P7382-16603-A each29.95



FRONT DOOR SILL PLATE

Front door rear or rear door rear section.
1977-78 (2wd, 4wd Ser. 10-30 (2 or 4 Door)
1979-84 (2wd, 4wd, Ser. 20-30 (Cab 4 Door) (left hand)

P7784-16603-LH each24.95
1977-78 (2wd, 4wd, Ser. 10-30 (2 or 4 door)

1979-84 (2wd, 4wd, Ser. 20-30 (cab 4 door) (right hand)

P7784-16603-RH each24.95
1979-82 Blazer, Jimmy (left hand)

P7982-16603-LH each36.95
1979-82 (2wd, 4wd, Ser. 10, Blazer, Jimmy) (right hand)

P7982-16603-RH each36.95



FLOOR AND SEAT SUPPORT BUMPER

(req. 2)
1969-72 Ser 10-30 (Blazer, Cab & Suburban)
1973-80 All, Blazer, Jimmy
P6972-16650-BM each1.95



1969-72

1973-80

CENTER CONSOLE

Black, can be dyed any color
1969-72 Pickup
P6972-16650-CC each169.95
1973-80 Pickup
P7380-16650-CC each169.95



CENTER SEAT LATCH HANDLE

Back cushion latch rod handle
1979-84 (2wd, 4wd, Ser. 10-30, Suburban)
P7984-16674-A each19.95



SEAT FRAME BUMPER & SCREW KIT

1947-54 Pickup
P4754-16679-MB kit.5.95

SAVE ON SHIPPING! FREE DELIVERY TO ANY SWAP MEET WE ATTEND. JUST ASK FOR DETAILS!

Spectacular Customer Service!



DOORS, MIRRORS, WINDSHIELD, INTERIOR PARTS



SEAT ADJUSTMENT ROD GROMMET

1950-54 Pickup
P5054-16682-G each2.95



SEAT ADJUSTER LOCKING LEVER KNOB

(drivers seat)
1967-70 All
1969-72 Ser 10-20 (Panel)
P6770-16682-KN each4.95



SEAT BELT ASSEMBLY

With hardware & chrome buckle. Total length 74". These are a universal seat belt offered in a selection of colors.

1947-72 Pickup (Bright blue)
P4772-16714-BBL each29.95
1947-72 Pickup (Black)
P4772-16714-BLK each29.95
1947-72 Pickup (Brown)
P4772-16714-BRN each29.95
1947-72 Pickup (Dark blue)
P4772-16714-DKBL each29.95
1947-72 Pickup (Green)
P4772-16714-GR each29.95
1947-72 Pickup (Gray)
P4772-16714-GRY each29.95
1947-72 Pickup (Maroon)
P4772-16714-M each29.95
1947-72 Pickup (Parchment)
P4772-16714-PAR each29.95
1947-72 Pickup (Red)
P4772-16714-RD each29.95
1947-72 Pickup (Tan)
P4772-16714-T each29.95



FRONT SEAT BELT GUIDE COVER

Paint as required
1976-78 (2wd, 4wd, Ser. 10-20, Suburban)
P7678-16714-A each4.95



BENCH SEAT TOP AND BOTTOM CUSHIONS

Factory original, replacement foam cushions.
1967-68 Chevy/GMC Pickup
P6768-16715-BENCH set.259.95
1969-72 Chevy/GMC Pickup
P6972-16715-BENCH set.329.95
1973-81 Chevy/GMC Pickup
P7381-16715-BENCH set.359.95
1982-87 Chevy/GMC Pickup
P8287-16715-BENCH each239.95



BUCKET SEAT FOAM CUSHIONS

Includes bottom and back, one pair does one side.
1967-68 Chevy/GMC Pickup
P6768-16715-CSH Pair299.95
1969-70 Chevy/GMC Pickup
P6970-16715-CSH Pair299.95
1971-72 Chevy/GMC Pickup
P7172-16715-CSH Pair299.95

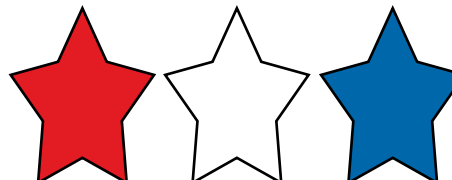

BENCH SEAT UPHOLSTERY

Special order. Complete with split bottom cushion (padding, burlap, and basic instructions included)
1937 Pickup (Black) Split Bottom Cushion
P37-16717-BLSPO set.249.95
1937 Pickup - Split Bottom Cushion (Brown)
P37-16717-BRSPO kit249.95
1938 Pickup - Specify Black or Brown
P38-16717-SPO kit.199.95
1939-46 Pickup
(Specify brown, black, or maroon)
P3946-16717-SPO kit.149.95
1947-49 Pickup (Specify Black, Brown, Dark Maroon, or Gray)
P4749-16717-ASPO kit149.95
1947-49 GMC Pickup (w/french stitching, specify color or Brown or Black)
P4749-16717-BSPO kit199.95
1950-55 Pickup (Black or Brown)
P5055-16717-ASPO each169.95
1950-55 GMC Pickup
(w/ french stitching, specify Black or Brown)
P5055-16717-BSPO each199.95
1950-55 Pickup
(Spanish grain, specify Maroon or Brown only)
P5055-16717-SGASPO each199.95
1950-55 GMC Pickup (Spanish grain seat upholstery, specify color or Brown or Maroon)
P5055-16717-SGBSPO each249.95
1955-59 Pickup
(specify color of Black, Beige or Grey)
P5559-16717-SPO each149.95
1960-66 Pickup (non-pleated, specify Brown, Green, Blue, Black or Tan)
P6066-16717-ASPO set249.95
1960-66 Pickup (pleated, specify Brown, Green, Blue, Black or Fawn Gray/Tan)
P6066-16717-BSPO set299.95
1967-72 Pickup (non-pleated, specify color Blue, Green, Black or Off White)
P6772-16717-ASPO each249.95
1967-72 Pickup (pleated vinyl, specify color Blue, Green, Black or Off White)
P6772-16717-BSPO each299.95



SEAT TO FRAME 'C' CLIPS

1937-59 Pickup
P3759-16717-CL set.6.95

DOORS, MIRRORS, WINDSHIELD, INTERIOR PARTS



1969-70, black



1967-68, black



1969-70, dark blue



1967-68, bright red

BUCKET SEAT COVER

Made with madrid grain vinyl, features a repeating pattern of dielectrically heat sealed vertical pleats which resemble double stitch bar seams. There is also a center fold-down arm rest cover which has a design that is very similar to the bucket seat design. One set does both seats. 1967-68 Pickup (Aqua)

- P6768-16717-AQ set299.95**
1967-68 Pickup (Bright blue)
- P6768-16717-BB set299.95**
1967-68 Pickup (Black)
- P6768-16717-BK set299.95**
1967-68 Pickup (Bright red)
- P6768-16717-BR set299.95**
1967-68 Pickup (Dark aqua)
- P6768-16717-DA set299.95**
1967-68 Pickup (Light green)
- P6768-16717-LG set.299.95**
1967-68 Pickup (Light saddle)
- P6768-16717-LS set.299.95**
1967-68 Pickup (Metallic green)
- P6768-16717-MG set299.95**
1967-68 Pickup (Off white)
- P6768-16717-OW set299.95**
1967-68 Pickup (Red)
- P6768-16717-RD set299.95**
1969 Pickup - (Aqua)
- P69-16717-AQ set229.95**
1969-70 Pickup (Bright blue)
- P6970-16717-BB set229.95**
1969-70 Pickup (Black, walrus grain vinyl)
- P6970-16717-BK set229.95**
1969-70 Pickup (Bright red)
- P6970-16717-BR set229.95**
1969-70 Pickup (Dark aqua)
- P6970-16717-DA set229.95**
1969-70 Pickup (Dark blue)
- P6970-16717-DB set229.95**
1969-70 Pickup (Metallic green)
- P6970-16717-MG set229.95**
1969-70 Pickup (Red)
- P6970-16717-RD set229.95**
1969-70 Pickup (Saddle)
- P6970-16717-SD set.229.95**
1969 70 Pickup (Sandlewood)
- P6970-16717-SW set229.95**
1970 Chevy (Aqua, walrus grain)
- P70-16717-AQ set229.95**



SPANISH GRAIN SEAT UPHOLSTERY

Special order, specify Brown or Maroon. 1947-49 Pickup
P4749-16717-SGASPO kit199.95
 1947-49 GMC Pickup (with french stitching)
P4749-16717-SGBSPO kit249.95



MADRID GRAIN VINYL REPLACEMENT UPHOLSTERY

As original, must order burlap seperately if needed. 1947-54 Chevy Pickup (Black)
P4754-16717-MDBLKSP0 each . . 199.95
 1947-54 Chevy Pickup (Dark saddle)
P4754-16717-MDDKSDLSP0 each199.95
 1947 54 Chevy Pickup (Medium grey)
P4754-16717-MDMGYSP0 each . . 199.95
 1947-54 Chevy Pickup (Maroon)
P4754-16717-MDMRNSPO each . . 199.95
 1947-54 Chevy Pickup (Navy blue)
P4754-16717-MDNBLSP0 each . . 199.95



ALL VINYL BENCH SEAT UPHOLSTERY

Palimino 1973-80 Pickup
P7380-16717-PAL set179.95



DELUXE HOUNDSTOOTH VINYL UPHOLSTERY

Elk & walrus grain heavyweight vinyl foam backing. Special order, specify bench or bucket seats. 1971-72 Cheyenne Pickup (Will Also Fit 1967-70)
P7172-16717-HASPO set.299.95
 1971-72 Pickup (black)
P7172-16717-HBKSP0 set299.95
 1971-72 Cheyenne Pickup (Will Fit 1967-70 Pickup)
P7172-16717-HBSPO set.299.95

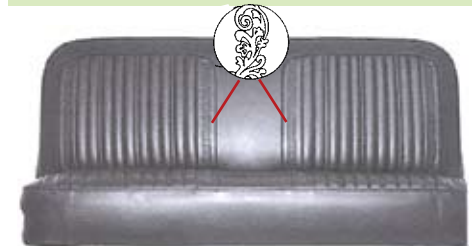

VINYL BENCH SEAT COVER

With scroll work. 1967-72 Pickup
P7172-16717-SBKSP0 set229.95
 1971-72 Cheyenne Pickup
P7172-16717-SCSP0 set.229.95



MADRID GRAIN VINYL WITH REGAL VELOUR CLOTH INSERTS UPHOLSTERY SET

Does upper and lower section of bench seat. **Two-tone available only**
 1973-80 Chevy/GMC Pickup
P7380-16717-CSPO set199.95

SHOW OFF YOUR TRUCK!



DOORS, MIRRORS, WINDSHIELD, INTERIOR PARTS

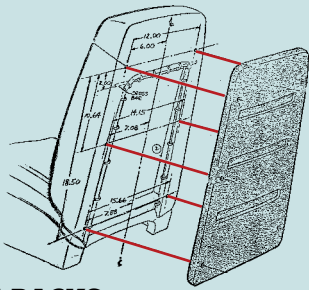

SEAT BACKS

1969-72 Blazer
P6972-16720-SB pair99.95



COAT HOOK

1967-72 Ser 10-20 (Suburban, Exc custom dlx.)
P6772-16742-A each4.95



COAT HOOK SCREW SET

1967-72 Pickup
P6772-16742-SC set.95



PILLER POST MOLDINGS

Paint to match.
 1975-80 Pickup
P7580-16742-BLK pair.64.95



Gotta question?
 Ask Mike! He's here to help.

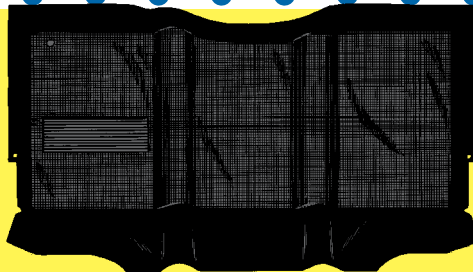

BLACK RUBBER FLOOR MAT

1937-46 Pickup (3 or 4 Speed)
P3746-16800-A each69.95
 1947-55 Chevy/GMC Pickup (1/2 Ton to 2 ton)
 (For low tunnel with tails)
P4754-16800-A each99.95
 1955-59 Chevy/GMC Pickup (w/ Small transmission (1/2 ton only) (For 1/2 ton with small transmissions)
P5559-16800-A each99.95
 1955-59 Chevy/GMC (w/ 4-Speed Transmission)
P5559-16800-B each99.95
 1960-63 Chevy/GMC Pickup (w/ large transmission)
 (For trucks with small transmission hump)
P6063-16800-A each99.95
 1960-63 Chevy/GMC Pickup (w/ small transmission)
 (For trucks with large bolt in transmission humps)
P6063-16800-B each99.95
 1964-66 Chevy/GMC (Does not fit 4 speed manual transmission)
P6466-16800-A each99.95
 1964-66 Chevy/GMC (Fits 4 speed manual transmissions)
P6466-16800-B each99.95
 1967-70 Chevy/GMC
P6770-16800-C each39.95
 1967-72 Chevy/GMC (Small trans. (small hump) stops under seat)
P6772-16800-A each69.95
 1967-72 Chevy/GMC (For four wheel drive, turbo 400, or four speed trans)
P6772-16800-B each69.95
 1970-72 Chevy/GMC (For Pickups with small hump floor pans including turbo 350, and 3 speed standard transmission. Includes tails that wrap around seat)
P7072-16800-A each79.95
 1970-72 Chevy/GMC (For Pickups with turbo 400, 4x4, or 4 speed transmission. Includes tails that wrap around seat)
P7072-16800-B each79.95
 1973-80 Chevy/GMC (Large transmission, has no cut out for 4x4 but can use)
P7380-16800-B each69.95
 1980-90 Chevy, GMC 2 ton C50-70 (2 ton c50-70 except coe, black)
P8090-16800-A each69.95
 1981-87 Chevy GMC 1/2 to 1 1/2 ton large tran (Stops under seat, perforated for dimmer switch, no felt)
P8187-16800-A each69.95
 1981-87 Pickup (Small hump)
P8188-16800-A each69.95
 1983-93 Chevy GMC S10 and S15 Pickup (Complete with felt and fiberglass)
P8393-16800-A each179.95
 1988-97 Chevy GMC 1/2 to 1 1/2 ton Pickup (Small transmission without shift cut ours, use old mat as pattern)
P8897-16800-A each199.95

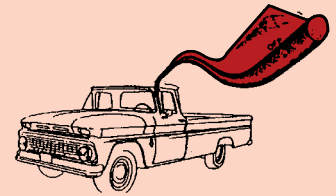

ANTIQUE STYLE WINDLACE

Cloth covered, sponge filled. 1/2", sold per foot. Round sponge cord covered with early day style of material.
 Black
 1932-72 All
WL-02600-70A foot3.95
 Grey
WL-02600-70B foot3.95
 Tan
WL-02600-70C foot3.95
 Brown
WL-02600-70D foot3.95
 Dark blue
WL-02600-70E foot3.95
 Red
WL-02600-70G foot3.95
 White
WL-02600-70H foot3.95
 Dark green
WL-02600-70J foot.3.95
 Maroon
WL-02600-70K foot3.95
 Antique brown
WL-02600-70N foot3.95
 Aqua blue
WL-02600-70O foot3.95



UPHOLSTERY HOG RINGS

1932-72 Pickup
 Medium (3/8")
B-162599-A pkg of 502.95
 1932-72 Pickup
 Large (3/4")
B-162599-B pkg of 502.95



HOG RING PLIERS

X-163599 each24.95



PICKUP BED PARTS



Photos of assembled beds are shown

UNASSEMBLED PICKUP BEDS

TOP QUALITY!

Die stamped steel

USA MADE!

This is the Narrow Bed

Special order

This is the complete pickup bed, but in an UNASSEMBLED kit form (not riveted together, bolted together, etc.). Includes: Bed Sides, Bed Front Panel, Cross Sills, Tailgate & Chains, Wood Flooring, Bed Angle Strips, Stake Pockets, and hardware.

***PLEASE SPECIFY** whether you would prefer your bed with or without stake pocket holes

***OPTIONS:** For an extra \$88.00 you may receive the sides of your bed in assembled form. For an extra \$2.00 per piece you may receive the bed strips and angle strips pre-punched.

UNASSEMBLED PICKUP BED ASSEMBLY

Includes: bed front, tailgate, bed sides, stake pockets, wood, bed and angle strips, cross sills, and hardware.
1928-33 Chevy/GMC Pickup (1/2 ton)

P2833-17600-kit 1430.95

1934-36 Pickup (1/2 ton)

P3436-17600-kit 1225.95

1937-40 Pickup (1/2 ton)

P3740-17600-kit 1225.95

1940 Pickup White 6 foot bed

P40-17600-kit 1250.95

1941-46 Pickup (1/2 ton)

P4146-17600-kit 1115.95

1947-53 Pickup (1/2 ton)

Zinc. (Stainless steel upgrade is additional \$225.00.)

P4753-17600-kit 1250.95

1954-72 Stepside Pickup (1/2 ton)

Stainless steel upgrade is additional \$225.00.

P5472-17600-kit 1375.95

Photos of assembled beds are shown



****NOTE:** Add an extra \$50.00 for crating.

BED ASSEMBLY INSTRUCTION SHEET

1947-53 Short Stepside beds

P4753-17600-INST each 9.95



PICKUP BED PARTS

ASSEMBLED PICKUP BEDS

TOP QUALITY!



USA MADE!

Special order

Die stamped steel

This is the complete ASSEMBLED pickup bed, drop shipped from the manufacturer to your door! Please allow 2-4 weeks for motorfreight delivery. Includes: Bed Sides, Bed Front Panel, Cross Sills, Tailgate & Chains, Red Oak Wood Flooring, Polished Stainless Steel Bed Strips, Bed Angle Strips, Stake Pockets, and hardware.

This is the Narrow Bed

*PLEASE SPECIFY whether you would prefer your bed with or without stake pocket holes

**NOTE: Add an extra \$100.00 for crating.

ASSEMBLED PICKUP BED

1928-33 Chevy/GMC Pickup (1/2 ton)
P2833-17600-ASSY2043.00

1934-36 Pickup (1/2 ton)
These bed sides do not permit the use of stock rear shock absorbers. *When ordering, please specify* whether you would prefer your tailgate with or without "CHEVROLET" stamping.

P3436-17600-ASSY1638.00

1937-40 Pickup (1/2 ton)
When ordering, please specify whether you would prefer your tailgate with or without "CHEVROLET" stamping.

P3740-17600-ASSY1638.00

1940 Pickup White 6 foot bed
When ordering, please specify whether you would prefer your tailgate with or without "CHEVROLET" stamping.

P40-17600-ASSY1663.00

1941-46 Pickup (1/2 ton)
(Does not come with "CHEVROLET" stamping option)

P4146-17600-ASSY1563.00

1947-53 Pickup (1/2 ton)
Zinc. (Stainless steel upgrade is additional \$225.00.)
(comes with "CHEVROLET" stamping on tailgate)

P4753-17600-ASSY1663.00



PICKUP BED PARTS

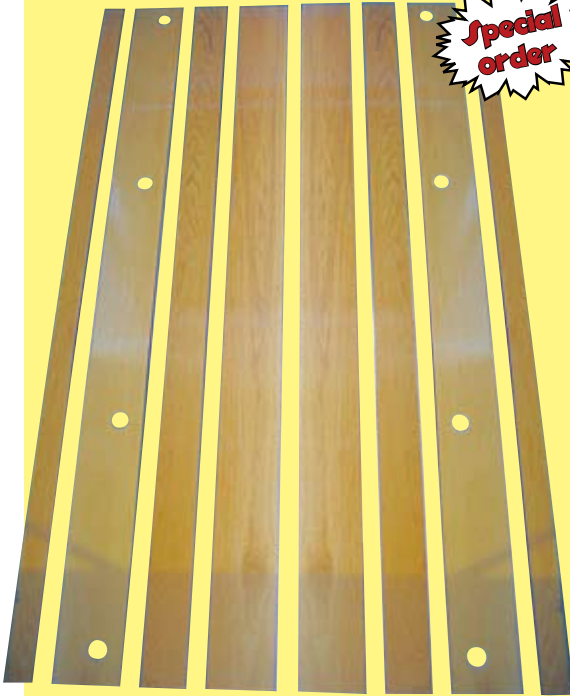

OAK BED WOOD KIT

Comes w/all necessary mounting holes pre-drilled.

1934-36 Chevy Pickup (Long Stepside)	
P3436-17000-A kit	459.95
1934-36 Chevy (Short Stepside)	
P3436-17000-B kit	429.95
1937-39 Chevy Pickup (Long Stepside)	
P3739-17000-A kit	459.95
1937-39 Chevy (Short Stepside)	
P3739-17000-C kit	429.95

1940-45 Chevy Pickup (Long Stepside)		1958-59 Chevy (Short Wide Bed)	
P4045-17000-A kit	459.95	P5859-17000-B kit	489.95
1940-45 Chevy (Short Stepside)		1958-59 Chevy (Long Wide Bed)	
P4045-17000-B kit	429.95	P5859-17000-C kit	549.95
1946 Pickup (Long Stepside)		1960-62 Chevy (Long Stepside)	
P46-17000-A kit	459.95	P6062-17000-A kit	459.95
1946 Chevy (Short Stepside)		1960-62 Chevy (Long Widebed)	
P46-17000-B kit	429.95	P6062-17000-B kit	549.95
1947-50 GMC (Long Stepside 1/2 Ton)		1960-62 Chevy (Short Stepside)	
P4750-17000-A kit	374.95	P6062-17000-C kit	389.95
1947-50 Chevy (Long Stepside 3/4 Ton)		1960-62 Chevy (Short Widebed)	
P4750-17000-B kit	459.95	P6062-17000-D kit	489.95
1947-50 Chevy 1/2 ton, 1 ton (107")		1963-66 Chevy (Long Stepside)	
P4750-17000-C kit	499.95	P6366-17000-A kit	459.95
1947-50 (Short Stepside)		1963-66 Chevy (Long Widebed)	
P4750-17000-D kit	429.95	P6366-17000-B kit	549.95
1951-53 GMC (Long Stepside 1/2 Ton)		1963-66 Chevy (Short Stepside)	
P5153-17000-A kit	459.95	P6366-17000-C kit	429.95
1951-53 Chevy (1/2 Ton) (107")		1963-66 Chevy (Short Widebed)	
P5153-17000-C kit	499.95	P6366-17000-D kit	489.95
1951-53 Pickup (Short Stepside)		1967-72 Chevy (Long Widebed)	
P5153-17000-D kit	429.95	P6772-17000-B kit	549.95
1951-53 Pickup (Long Stepside 3/4 Ton)		1967-72 (Short Stepside)	
P5153-17000-E kit	459.95	P6772-17000-C kit	429.95
1954-55 Chevy (Short Stepside)		1967-72 Chevy (Short widebed)	
P5455-17000-A kit	429.95	P6772-17000-D kit	489.95
1954-55 Chevy 1st Series (Long Step 3/4 Ton)		1967-72 Chevy (Long Stepside)	
(fits GMC 1/2 ton long step)		P6772-17000-F kit	459.95
P5455-17000-B kit	459.95	1967-72 (Longhorn)	
1954-55 Chevy 1st Ser (Long Step 3/4 Ton)		P6772-17000-G kit	599.95
P5455-17000-C kit	459.95	1973-80 Chevy (Long Widebed)	
1955-57 Chevy (Long Stepside 89")		P7379-17000-A kit	549.95
P5557-17000-A kit	459.95	1973-87 Chevy (Long Stepside)	
1955-59 Chevy (Short Stepside)		P7387-17000-A kit	459.95
P5559-17000-A kit	389.95	1973-87 Chevy (Short Stepside)	
1957-59 Pickup (Long Stepside 97")		P7387-17000-B kit	429.95
P5759-17000-A kit	459.95		

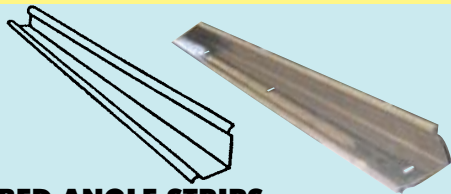

BED ANGLE STRIPS

These are the strips that fit in the corner of the bed.
Complete with mounting holes for easy installation.

Plain Steel

1934-36 Pickup	
P3436-17041-BS pair	26.95
1937-39 Pickup w/ long Stepside bed	
P3739-17041-AS pair	36.95
1937-39 Pickup w/ short Stepside bed	
P3739-17041-BS pair	29.95
1940-46 Pickup w/ long Stepside Bed	
P4046-17041-AS pair	36.95
1940-46 Pickup w/ short Stepside bed - 1/2 ton	
P4046-17041-BS pair	29.95
1947-53 Pickup w/ long Stepside Bed, 3/4 ton	
P4753-17041-AS pair	36.95
1947-53 Pickup w/ short Stepside bed -1/2 ton	
P4753-17041-BS pair	29.95
1947-53 (1 ton Pickup)	
P4753-17041-CS pair	34.95
1954-55 (1st Series w/ long Stepside bed, 3/4 Ton)	
P5455-17041-AS pair	36.95
1954-59 Pickup w/ short Stepside bed	
P5459-17041-AS pair	29.95

Pickup Bed Strips

1957 Pickup Stepside 89" long		1947-53 Pickup w/ short Stepside bed, 1/2 ton	
P5557-17041-AS pair	36.95	P4753-17041-SSB pair	49.95
1957-59 Pickup Stepside w/ 97" bed		1954-55 (1st series w/ long Stepside bed, 3/4 Ton)	
P5759-17041-AS pair	36.95	P5455-17041-SSA pair	56.95
1960-62 Pickup w/ long Stepside Bed		1954-59 Pickup w/ short Stepside Bed	
P6062-17041-AS pair	36.95	P5459-17041-SSA set	49.95
1960-66 Pickup w/ short Stepside Bed		1955-57 Pickup Stepside w/ 89" bed	
P6066-17041-AS pair	29.95	P5557-17041-SSA pair	56.95
1963-66 Pickup w/ long Stepside bed		1954-59 Pickup Stepside w/ 97" bed	
P6366-17041-AS pair	39.95	P5759-17041-SSA pair	56.95
1967-72 Pickup w/ long Stepside bed		1960-62 Pickup w/ long Stepside bed	
P6772-17041-AS pair	39.95	P6062-17041-SSA pair	56.95
1967-72 Pickup w/ short Stepside bed		1960-66 Pickup w/ short Stepside bed	
P6772-17041-BS pair	29.95	P6066-17041-SSA pair	49.95
		1963-66 Pickup w/ long Stepside bed	
		P6366-17041-SSA pair	49.95
		1967-72 Pickup w/ long Stepside bed	
		P6772-17041-SSA pair	59.95
		1967-72 Pickup w/ short Stepside bed	
		P6772-17041-SSB pair	49.95
		1973-87 Pickup w/ long Stepside Bed	
		P7387-17041-AS pair	39.95
		1973-87 w/ short Stepside bed	
		P7387-17041-BS pair	29.95
		1973-87 Pickup w/ long Stepside bed	
		P7387-17041-SSA pair	59.95
		1973-87 w/ short Stepside bed	
		P7387-17041-SSB pair	49.95

Stainless Steel

1934-36 Pickup	
P3436-17041-SSB pair	44.95
1937-39 Pickup w/ long Stepside bed	
P3739-17041-SSA pair	56.95
1937-39 Pickup w/ short Stepside bed	
P3739-17041-SSB pair	49.95
1940-46 Pickup w/ long Stepside bed	
P4046-17041-SSA pair	56.95
1940-46 Pickup w/ short Stepside bed, 1/2 ton	
P4046-17041-SSB pair	49.95
1947-53 Pickup w/ long Stepside bed, 3/4 ton)	
P4753-17041-SSA pair	56.95



PICKUP BED PARTS

PC - Powder Coated Black
SS - Stainless Steel
PS - Plain Steel

Pickup Bed Strips

PC - Powder Coated Black
SS - Stainless Steel
PS - Plain Steel

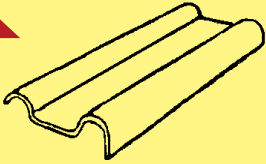

FLEETSIDE = WIDE BED
STEPSIDE = NARROW BED



PICKUP BED STRIPS

Without punched holes

- 1928-72 Ser.10 Pickup (79" long)
- PS: P-17438-AS each 5.95
- SS: P-17438-SSA each 13.95
- 1928-72 Ser.20 Pickup (97" long)
- PS: P-17438-BS each 7.95
- SS: P-17438-SSB each 12.95

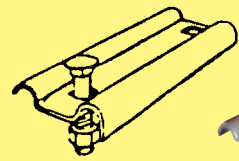

PICKUP BED STRIPS

Includes pre-punched holes.

- 1933 Pickup (Shortbed - Stepside)
- PC: P33-17438-A each 19.95
- 1934-36 (Longbed - Stepside)
- PC: P3436-17438-A each 26.95
- SS: P3436-17438-SSA each 14.95
- PS: P3436-17438-AS each 7.95
- 1934-36 (Shortbed - Stepside)
- PC: P3436-17438-B each 19.95
- SS: P3436-17438-SSB each 12.95
- PS: P3436-17438-BS each 6.95
- 1937-39 (Longbed - Stepside)
- PC: P3739-17438-A set 129.95
- SS: P3739-17438-SSA set 79.95
- PS: P3739-17438-AS set 36.95
- 1937-39 (Shortbed - Stepside)
- PC: P3739-17438-B set 99.95
- SS: P3739-17438-SSB set 62.95
- PS: P3739-17438-BS set 39.95
- 1940-46 (Longbed - Stepside)
- PC: P4046-17438-A each 26.95
- SS: P4045-17438-SSA set 119.95
- PS: P4045-17438-AS set 49.95
- 1940-46 (Shortbed - Stepside)
- PC: P4046-17438-B each 19.95
- SS: P4045-17438-SSB set 89.95
- PS: P4045-17438-BS set 39.95
- 1947-53 (Longbed - Stepside)
- PC: P4753-17438-A each 26.95
- SS: P4753-17438-SSA each 17.95
- PS: 4753-17438-AS each 7.95

- 1947-53 (Shortbed - Stepside)
- PC: P4753-17438-B each 12.95
- SS: P4753-17438-SET set 89.95
- PS: P4753-17438-BS each 6.95
- 1947-53 Ser.30 (Center Bed Strip- 1 Ton)
- PS: P4753-17438-CS each 8.95
- 1954-55 1ST Series (Longbed - Stepside)
- PC: P5455-17438-A set 179.95
- SS: P5455-17438-SSA set 119.95
- PS: P5455-17438-AS set 59.95
- 1954-59 (Shortbed - Stepside)
- PC: P5459-17438-A set 139.95
- SS: P5459-17438-SSA set 89.95
- PS: P5459-17438-AS set 59.95
- 1955-57 (Longbed - Stepside - 89")
- PC: P5557-17438-A set 179.95
- SS: P5557-17438-SSA set 119.95
- PS: P5557-17438-AS set 59.95
- 1957-59 (Longbed - Stepside - 97")
- PC: P5759-17438-A set 179.95
- SS: P5759-17438-SSA set 119.95
- PS: P5759-17438-AS set 59.95
- 1958-59 (Long Wide Bed)
- PC: P5859-17438-A set 289.95
- SS: P5859-17438-SSA set 174.95
- PS: P5859-17438-AS set 99.95
- 1958-59 (Short Wide Bed)
- PC: P5859-17438-B set 219.95
- SS: P5859-17438-SSB set 149.95
- PS: P5859-17438-BS set 79.95
- 1960-62 (Long Stepside)
- PC: P6062-17438-A set 179.95
- SS: P6062-17438-SSA set 119.95
- PS: P6062-17438-AS set 59.95
- 1960-62 (Long Wide Bed)
- PC: P6062-17438-B set 234.95
- SS: P6062-17438-SSB set 134.95
- PS: P6062-17438-BS set 79.95
- 1960-66 (Short Stepside)
- PC: P6066-17438-A set 139.95
- SS: P6066-17438-SSA set 89.95
- PS: P6066-17438-AS set 59.95

- 1960-66 (Short Wide)
- PC: P6066-17438-B set 179.95
- SS: P6066-17438-SSB set 114.95
- PS: P6066-17438-BS set 69.95
- 1963-66 (Long Stepside)
- PC: P6366-17438-A set 179.95
- SS: P6366-17438-SSA set 119.95
- PS: P6366-17438-AS set 59.95
- 1963-66 (Long Wide Bed)
- PC: P6366-17438-B set 234.95
- SS: P6366-17438-SSB set 134.95
- PS: P6366-17438-BS set 79.95
- 1967-72 (Long Stepside)
- PC: P6772-17438-A set 179.95
- SS: P6772-17438-SSA set 119.95
- PS: P6772-17438-AS set 59.95
- 1967-72 (Long Wide Bed)
- PC: P6772-17438-B set 234.95
- SS: P6772-17438-SSB set 134.95
- PS: P6772-17438-BS set 79.95
- 1967-72 (Longhorn Wide Bed)
- PC: P6772-17438-C set 259.95
- SS: P6772-17438-SSLGH set ... 194.95
- 1967-72 (Short Stepside)
- PC: P6772-17438-D set 139.95
- SS: P6772-17438-SSC set 99.95
- PS: P6772-17438-CS set 49.95
- 1967-72 (Short Wide Bed)
- PC: P6772-17438-E set 179.95
- SS: P6772-17438-SSD set 119.95
- PS: P6772-17438-DS set 69.95
- 1973-79 (Long Wide)
- PC: P7379-17438-A set 159.95
- SS: P7379-17438-SSA set 89.95
- PS: P7379-17438-AS set 99.95
- 1973-87 (Long Stepside)
- PC: P7387-17438-A set 159.95
- SS: P7387-17438-SSA set 99.95
- PS: P7387-17438-AS set 44.95
- 1973-87 (Short Stepside)
- PC: P7387-17438-B set 119.95
- SS: P7387-17438-SSC set 119.95
- PS: P7387-17438-BS set 44.95

PICKUP BED PARTS



Bed strip bolt kits



SS - Stainless Steel
PS - Plain Steel



BED STRIP BOLT KITS

These complete kits include bolts and washers for every bed strip and angle strip on your pickup bed.
1937-39 (Short - Stepside)

PS: P3739-17438-MBA kit 49.95
SS: P3739-17438-MBSSA set 99.95

1937-39 (Long - Stepside)

PS: P3739-17438-MBB kit 49.95
SS: P3739-17438-MBSSB kit 119.95

1940-45 (Long - Stepside)

PS: P4045-17438-MBA kit 49.95
SS: P4045-17438-MBSSA kit 99.95

1946 (Long - Stepside)

PS: P46-17438-MBA kit 49.95
SS: P46-17438-MBSSA kit 99.95

1946 (Short - Stepside)

PS: P46-17438-MBB kit 49.95
SS: P46-17438-MBSSB kit 99.95

1947-50 (Long - Stepside)

PS: P4750-17438-MBA kit 49.95
PS: P4750-17438-MBSSA kit 99.95

1947-50 (Short Stepside)

PS: P4750-17438-MBB kit 49.95
SS: P4750-17438-MBSSB kit 89.95

1951-53 (Long Stepside)

PS: P5153-17438-MBA kit 49.95
SS: P5153-17438-MBSSA kit 99.95

1951-53 (Short Stepside)

PS: P5153-17438-MBB kit 42.95
SS: P5153-17438-MBSSB kit 86.95

1954-55 1ST Series (Short - Stepside)

PS: P5455-17438-MBA kit 49.95
SS: P5455-17438-MBSSA kit 84.95

1954-55 1ST Series (Long - Stepside - 89")

PS: P5457-17438-MBA kit 49.95
SS: P5457-17438-MBSSA kit 99.95

1955-59 (Short - Stepside)

PS: P5559-17438-MBA kit 49.95
SS: P5559-17438-MBSSA kit 84.95

1957-59 (Long - Stepside - 97")

PS: P5759-17438-MBA kit 49.95
SS: P5759-17438-MBSSA kit 99.95

1958-59 (Long - Wide)

PS: P5859-17438-MBA kit 69.95
SS: P5859-17438-MBSSA kit 129.95

1958-59 (Short - Wide)

PS: P5859-17438-MBB kit 59.95
SS: P5859-17438-MBSSB kit 99.95

1960-62 (Long - Stepside Bed)

PS: P6062-17438-MBA kit 49.95
SS: P6062-17438-MBSSA kit 119.95

1960-62 (Long - Wide)

PS: P6062-17438-MBB kit 69.95
SS: P6062-17438-MBSSB kit 129.95

1960-66 (Short - Stepside)

PS: P6066-17438-MBA kit 49.95
SS: P6066-17438-MBSSA kit 99.95

1960-66 (Short - Wide)

PS: P6066-17438-MBB 59.95
SS: P6066-17438-MBSSB kit 99.95

1963-66 (Long - Stepside)

PS: P6366-17438-MBA kit 49.95
SS: P6366-17438-MBSSA kit 99.95

1963-66 (Long - Wide)

PS: P6366-17438-MBB kit 69.95
SS: P6366-17438-MBSSB kit 119.95

1967-72 (Long-stepside bed)

PS: P6772-17438-MBA kit 49.95
SS: P6772-17438-MBSSA kit 99.95

1967-72 (Long-wide bed)

PS: P6772-17438-MBB kit 69.95
SS: P6772-17438-MBSSB kit 119.95

1967-72 (Short stepside bed)

PS: P6772-17438-MBC kit 49.95
SS: P6772-17438-MBSSC kit 84.95

1967-72 (Short-wide bed)

PS: P6772-17438-MBD kit 59.95
SS: P6772-17438-MBSSD kit 99.95

1967-72 (Longhorn - 103")

SS: P6772-17438-MBSSLGH kit 169.95

1973-80 (Long wide)

SS: P7380-17438-MBSSA kit 129.95
PS: P7380-17438-MBA set 69.95

1973-87 (Long Stepside)

SS: P7387-17438-MBSSA kit 129.95
PS: P7387-17438-MBA set 69.95

1973-87 (Short stepside)

SS: P7387-17438-MBSSB kit 114.95
PS: P7387-17438-MBB set 69.95

TRUCK BED BOLT SQUARE HOLE WASHER

1947-72 Chevrolet and GMC Truck
P4772-17438-W each 95

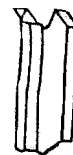

FRONT BED STAKE POCKET

Die stamped steel - primered

1928-33 Pickup
P2833-17500-AF each 64.95

1934-38 Pickup
P3438-17500-AF each 47.95

1939-53 Pickup
P3953-17500-AF each 47.95

1954-72 Pickup (left hand)
P5472-17500-AL each 69.95

1954-72 Pickup (right hand)
P5472-17500-AR each 69.95



REAR BED STAKE POCKET

Die stamped steel - primered

1928-33 Pickup
P2833-17500-AR each 64.95

1934-38 Pickup
P3438-17500-AR each 47.95

1939-53 Pickup (left hand)
P3953-17500-BL each 59.95

1939-53 Pickup (right hand)
P3953-17500-BR each 59.95

1954-72 Pickup (left hand)
P5472-17500-BL each 79.95

1954-72 Pickup (right hand)
P5472-17500-BR each 79.95

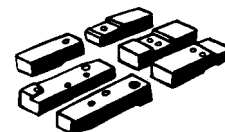

BED WOOD MOUNTING BLOCKS

1937-39 Chevy/ GMC Pickup (Short Stepside Bed)
P3739-17001-EA kit 24.95

1941-46 Pickup (Long Stepside 3/4 Ton)
P4146-17001-EA each 29.95

1941-46 Pickup (Short Stepside bed)
P4146-17001-EB each 24.95

1947-53 Pickup (Long Stepside Bed 3/4 Ton)
P4753-17001-EA each 24.95

1947-53 Pickup (Short Stepside bed)
P4753-17001-EB kit 19.95

1955-72 Pickup (Longbed)
P5572-17001-EA each 14.95



PICKUP BED PARTS



BED FLOOR PATCH PANEL

Stamped steel, (48" x 16")
1967-72 Pickup
P6772-17400-A each34.95



CROSS SILL REINFORCEMENT STRIP

Complete w/ mounting holes for easy installation.
1957-59 Long Bed Stepside
1958-59 Pickup (Fleetside)
49.5" long.
P5859-7009-A each34.95
1958-59 Pickup (Fleetside)
72" long
P5859-7009-B each34.95
1960-72 Chevy (Fleetside)
P6072-7009-A each36.95
1960-72 Pickup (Stepside)
P6072-7009-B each29.95

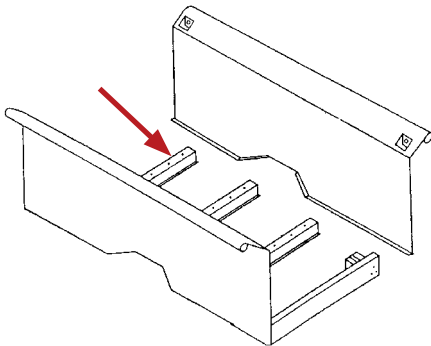

FRONT CROSS SILL

Complete with mounting holes for installation.
Stamped steel.
1947-50 Pickup (Stepside)
P4750-7012-B each29.95
1951-53 Pickup (Stepside)
P5153-7012-B each29.95

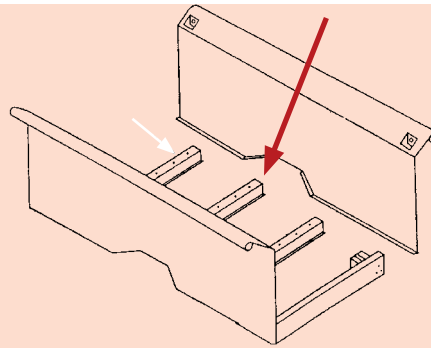
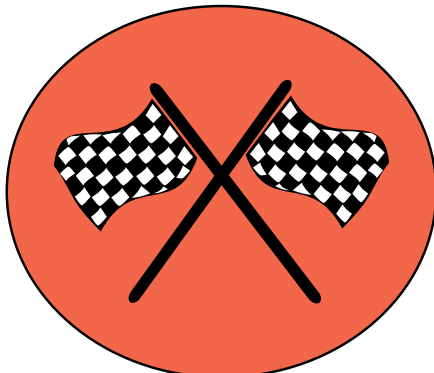

CENTER CROSS SILL

Stamped steel, complete with mounting holes.
1934-46 Pickup
P3446-7012-A each24.95
1941-45 Pickup (Stepside)
P4145-7012-A each29.95
1947-50 Pickup (Stepside)
P4750-7012-A each29.95
1951-53 Pickup (Stepside)
P5153-7012-A each29.95
1954-55 Pickup (Stepside) 1st series
P5455-7012-A each29.95
1955-59 Pickup (Stepside)
P5559-7012-A each29.95
1958-59 Pickup (Fleetside)
P5859-7012-A each36.95
1960-62 Pickup (Fleetside)
P6062-7012-A each36.95
1960-62 Pickup (Stepside)
P6062-7012-B each29.95
1963-72 Pickup (Fleetside)
P6372-7012-A each36.95
1963-72 Pickup (Stepside)
P6372-7012-B each29.95
1973-87 Pickup (Stepside)
P7387-7012-A each29.95



REAR CROSSMEMBER

Die stamped steel, ready to install.
1934-39 Pickup
P3439-7014-A each79.95
1941-46 Pickup (Stepside)
P4146-7014-A each99.95
1947-50 1/2 Ton
P4750-7014-A each99.95
1947-53 3/4 Ton
P4753-7014-B each99.95
1951-53 1/2 Ton
P5153-7014-A each99.95
1954-55 Pickup, (1st series) Stepside 1/2 Ton
P5455-7014-A each99.95
1954-55 Pickup (Stepside 3/4 Ton)
P5455-7014-B each99.95
1955-59 Pickup (Stepside)
P5559-7014-A each99.95
1958-59 Pickup (Fleetside)
P5859-7014-A each144.95
1960-62 Pickup
P6062-7014-A each144.95
1960-62 Pickup (Stepside)
P6062-7014-B each99.95
1963-66 Pickup (Stepside)
P6366-7014-A each99.95
1963-72 Pickup (Fleetside)
P6372-7014-A each144.95
1967-72 Pickup (Stepside)
P6772-7014-A each99.95
1973-87 Pickup (Stepside)
P7387-7014-A each99.95



BED CROSS SILL TO FRAME PAD

Requires 2 per cross sill
1932-80 Pickup
B-17001-PAD each.....95

Chevy...



...American made!

Nancy keeps our office under control with a smiling face!



PICKUP BED PARTS



1928-33



1940-46

BED FRONT PANEL

Primered & ready to paint. Made in the same gauge steel as original.

1928-33 Pickup (45" wide)

P2833-17000-A each199.95

1934-40 Pickup (1/2 Ton) (45 3/4" wide)

P3440-17000-A each139.95

1937-39 Pickup (3/4 & 1 Ton) (45-3/4" wide)

P3739-17000-D each139.95

1940-46 Chevy/GMC Pickup (48 1/2" wide)

P4046-17000-A each139.95

1946-46 Chevy Pickup.

P46-17000-BF each109.95

1947-53 Chevy/GMC Pickup (50" wide)

P4753-17000-A each109.95

1954-59 Chevy/GMC (49-3/4" wide)

P5459-17000-A each129.95

1958-59 Pickup (Fleetside)

P5859-17000-D each159.95

1960-66 Pickup (Fleetside)

P6066-17000-A each159.95

1960-72 Chevy/GMC (49 3/4" wide)

P6072-17000-A each129.95

1967-72 Pickup (Fleetside)

(for pickups with steel floor, edp black)

P6772-17000-E each179.95

1967-72 Pickups (Fleetside)

(for Fleetside pickups with wooden floors, edp black)

P6772-17000-W each169.95

1973-87 Chevy/GMC Stepside Pickup

P7387-17000-S each109.95

1973-87 Fleetside Pickup

P7387-17000-F each69.95



P4753-17000-BT

BED FRONT PANEL WITH EMBOSSED BOWTIE

Die stamped steel.

1947-53 Chevy pickup (Stepside)

P4753-17000-BT each149.95

1954-59 Chevy pickup (Stepside)

(with embossed 'bowtie' for a custom look)

P5459-17000-BT each154.95



BED FRONT PANEL BOLT KIT

Hex head bolts & nuts

Late 1947 - Early 1955 (Stainless steel)

P4755-17000-MB kit4.95

1954-72 Chevy Stepside or Fleetside (Plain steel)

P5472-17000-MBA kit7.95

1954-72 Pickup (Stainless steel)

P5472-17000-MBSSA kit11.95



EXHAUST HEAT SHIELD

Bolts to bed wood in order to protect the wood.

Requires 1 per exhaust.

1941-72 Pickup

P4172-17002-EHS each5.95

1973-80 Pickup

P7380-17002-EHS each7.95

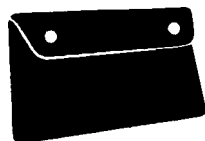

TOOL BAG

Black long grain material as original.

All

B-17005-A each9.95

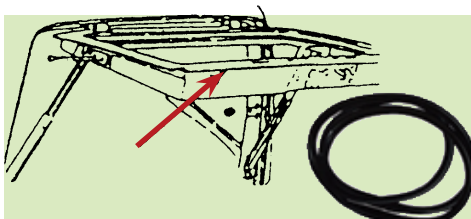

LIFTGATE AND TAILGATE SEALS

Rubber weatherstrip

1960-66 Suburban (liftgate & tailgate)

P6066-17185-KIT pair149.95

1967-72 Suburban (tailgate)

P6772-17185-TS each59.95

1967-72 Suburban (liftgate)

P6772-17185-HS each59.95

1973-91 Blazer (tailgate)

P7391-17185-AS each59.95

1973-91 Base model Suburban (tailgate)

P7391-17185-BS each59.95

1973-91 Silverado/Sierra Suburban (tailgate)

P7391-17185-CS each59.95

REAR HATCH GLASS GASKET

Rubber that seals back glass to hatch.

1969-72 Blazer

P6972-17185-A each79.95

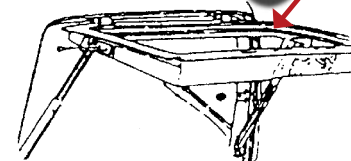

TAILGATE WINDOW GLASS CHANNEL ASSEMBLY

1973-84 Blazer, Jimmy (w/ removable top) (left hand)

P7378-17190-L each49.95

1973-84 Blazer, Jimmy (w/ removable top) (right hand)

P7378-17190-R each49.95

1973-84 (2wd, 4wd, Ser. 10/20, Suburban) (right hand)

P7378-17190-RH each49.95

TAILGATE LOCK ASSEMBLY



For Suburbans with electric tailgates.

1973-84 (Ser. 10/20 Suburban)

P7378-2188-EG each59.95

END GATE WINDOW REGULATOR GASKET



1979-84 Pickup & Suburban (w/ electric tail gate window)

P7984-17198-G each95

TAILGATE HANDLE



1967-72 Chevy/GMC Fleetside pickup and Blazer

P6772-17204-A each29.95

1973-80 Chevy/GMC Fleetside

P7380-17204-A each31.95



TAILGATE HANDLE AND LATCH ASSEMBLY



Complete with handle, 2 latches, 2 strikers, 2 hinges, and 2 linkage rods. 7pc kit.

1967-72 Chevy/GMC Fleetside pickups

P6772-17204-kit kit99.95

BLAZER/SUBURBAN END GATE ROLL UP HANDLE



1973-91 Blazer, Suburban

P7391-17204-A each59.95



PICKUP BED PARTS

BLAZER/ SUBURBAN END GATE LOCK

1973-91 Blazer, Suburban
P7391-17204-L each29.95



TAILGATE LATCH REMOTE CONTROL HANDLE SEAL

1977-82 (2wd, 4wd, Ser. 10, Blazer, Jimmy (w/ removable hard top)
1979-84 (2wd, 4wd, Ser. 10/20, Suburban)
P7778-17204-A each4.95

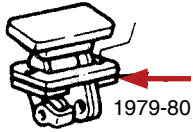
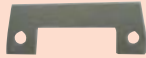

1979-80



1979-84

END GATE LATCH OPERATED HANDLE

1979-80 (2wd, 4wd, Ser. 10/20)
1979-80 Blazer, Jimmy (w/ folding top)
P7980-17204-A each129.95
1979-84 (2wd, 4wd, Ser. 10/20, Suburban)
1979-84 (2wd, 4wd, Ser. 10/20, Suburban (w/ removable hard top)
P7984-17204-A each99.95



TAILGATE HINGE ASSEMBLY

1934-39 Chevy Pickup
P3439-17208-A each29.95
1940-53 Chevy Pickup
P4053-17208-A each19.95
1954-72 Chevy Pickup
P5472-17208-A each9.95
1958-66 Pickup, Fleetside
P5866-17225-EB each9.95
1973-78 Blazer, Jimmy
1979-82 (2 & 4wd, Ser. 10, Blazer, Jimmy (w/ removable top)
P7378-17208-A each89.95
1973-84 (2wd, 4wd, Ser. 10/20, Suburban)
P7378-17208-B each99.95



TAILGATE HINGES

Fits either side.
1967-72 Pickup (Fleetside)
P6772-17208-PR pair59.95

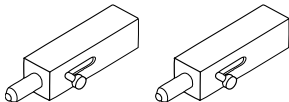

HIDDEN TAILGATE LATCH

Fits all years and types of trucks, stainless steel moving parts, replaces stock chains and hooks.
B-17225-HTL pair79.95

TAILGATE HINGE TRUNNION

1958-66 Pickup, Fleetside (w/ bracket and bolt)
P5866-17225-TGT pair19.95
1967-72 Fleetside and Blazer
P6772-17225-A pair19.95
1973-78 Fleetside, Blazer, Jimmy
P7378-17208-AT each8.95
1975-78 Fleetside, Blazer, Jimmy (exc. rem. top)
1979-80 (2wd, 4wd, Blazer, Jimmy (w/ folding top)
1979-80 (2wd, 4wd, Ser. 10-30)
(right hand)
P7578-17208-AT each22.95

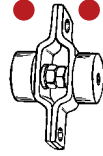

**CHEVROLET
GMC**

CHROME TAILGATE LETTER SET

'GMC'
1969-72 GMC Pickup
P6972-17215-GTGL set69.95
'Chevrolet'
1969-72 Chevy Pickup
P6972-17215-TGL set69.95

TAILGATE NAME PLATE

Rear right door, "Chevrolet"
1973-78 (2wd, 4wd, Ser. 10-30, Blazer (w/ body side mldgs., exc Suburban)
1979-80 (2wd, 4wd, Ser. 10-30 (w/ trail special)
P7378-17215-PA each36.95

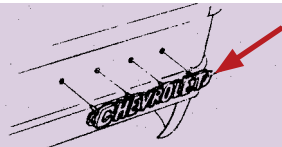

BODY REAR NAME PLATE

"Suburban"
1975-84 (2wd, 4wd, Ser. 10/20, Suburban (Chevy Only)
P7578-17215-PC each46.95



STEEL STEALTH LATCHES

Latches install into the top of the tailgate so you can eliminate those unsightly tailgate chains. Uses spring loaded pins to securely lock your tailgate into position.
1932-80 Stepside (plain steel)
B-17225-SL pair59.95
1932-80 Stepside (stainless steel)
B-17225-SSL pair89.95

TAILGATE CHAIN BRACKET

Die stamped steel, primered & ready to paint.
1934-40 Pickup (left hand)
P3440-17225-BLA each15.95
1934-40 Pickup (right hand)
P3440-17225-BRA each15.95

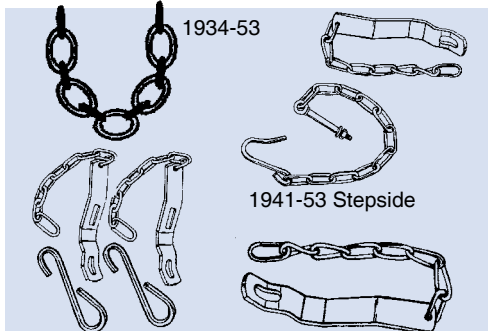
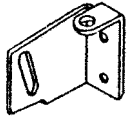

1934-53

1941-53 Stepside

1958-66 stainless steel
1958-66 zinc
TAILGATE CHAIN
1934-53 Pickup (formed steel)
P3453-17225-A each5.95
1941-53 Pickup, Stepside (zinc plated)
P4153-17225-AS pair24.95
1941-53 Pickup (stainless steel)
P4153-17225-SSA pair49.95
1954-72 Pickup (stainless steel)
P5472-17225-SSA pair49.95
1958-66 Fleetside Pickup (zinc plated)
P5866-17225-AS pair39.95
1958-66 Pickup, Fleetside (stainless steel)
P5866-17225-SSA pair149.95
1954-87 All Stepside Pickups (zinc plated)
P5487-17225-PR pair24.95

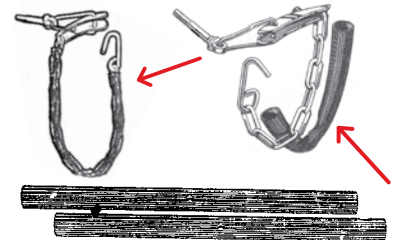

TAILGATE CHAIN COVER

Long grained material, ready to install. This is the chain that slips over your chains.
1934-53 Pickup (Black)
P3453-17225-PR pair7.95
1954-72 Pickup (exc. Suburban, Fleetside)
1979-84 2wd, 4wd, Ser. 10-30 (w/ Stepside)
1973-78 Stepside, Fenderside (Black) (requires 2)
P5472-17225-BC each4.95
1958-66 Pickup (Fleetside Only)
P5866-17225-BC pair2.95
1958-66 Pickup (Fleetside) (Black)
P5866-17225-BL pair7.95
1958-66 Pickup, Fleetside (Clear)
P5866-17225-CL pair7.95
1958 66 Pickup, Fleetside (Grey)
P5866-17225-GR pair9.95

PICKUP BED PARTS

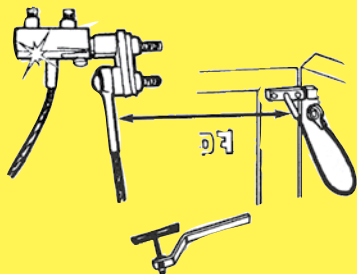

POLISHED STAINLESS COMBINED LATCH & CATCH ASSEMBLY

Show quality, hand polished. Cable is stainless with a clear plastic coating and is 22" long closed. Includes all hardware and installation tools. Just push gate closed and it latches!

B-17225-SS kit 150.00

New GLUE ON style. Installs with high power epoxy (included), no holes, same as above but uses glue (or weld before paint).

B-17225-GO kit 180.00



CAMEO TAILGATE RECOILER ASSEMBLY

1955-58 Cameo Pickup

P5558-17225-C each 68.95



CAMEO TAILGATE RECOILER CABLE

1955-58 Cameo Pickup

P5558-17225-CC each 52.95



TAILGATE PIVOT BOLT

Connects tailgate to bedside.

1958-66 Pickup, Fleetside (zinc plated)

P5866-17225-PVA each 7.95

1958-66 Pickup, Fleetside (stainless steel)

P5866-17225-PVSS each 19.95



TAILGATE LINK BUMPER

Fits on bedside. (Requires 2)

1967-72 Fleetside, Blazer

1979-81 (2wd, 4wd, (Blazer, Jimmy) w/ folding top)

1973-78 Fleetside, Wideside, Blazer, Jimmy

1979-84 (2wd, 4wd, Ser. 10-30, Fleetside)

P6772-17225-BM each 4.95



Special order

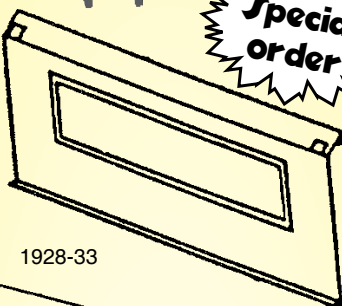

1928-33

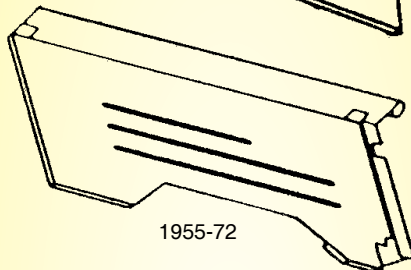

1955-72

BED SIDE PANEL

Die stamped steel - primed (stock)

1928-33 Pickup (right hand)

P2833-17505-A each 349.95

1928-33 Pickup (left hand)

P2833-17505-B each 349.95

1934-36 (1/2 Ton) Pickup (left hand)

(custom - not for use w/ stock shock absorbers)

P3436-17505-AL each 299.95

1934-36 (1/2 Ton) Pickup (right hand)

(custom only - not for use with stock shock absorbers)

P3436-17505-AR each 299.95

1934-36 (3/4 ton) Pickup (left hand)

(note: note for use with stock shock absorbers)

P3436-17505-BL each 299.95

1934-36 (3/4 ton) Pickup (right hand)

(note - not for use with stock shock absorbers)

P3436-17505-BR each 299.95

1937-40 (1/2 ton) Pickup (left hand)

P3740-17505-AL each 299.95

1937-40 (1/2 ton) Pickup (right hand)

P3740-17505-AR each 299.95

1937-40 (3/4 ton) Pickup (left hand)

P3740-17505-BL each 299.95

1937-40 (3/4 ton) Pickup (right hand)

P3740-17505-BR each 299.95

1941-53 (1/2 Ton) Pickup (left hand)

must ship truckline

P4153-17505-AL each 349.95

1941-53 (1/2 ton) Short Stepside (right hand)

must ship freightline

P4153-17505-AR each 319.95

1941-53 (3/4 ton) Pickup (left hand)

P4153-17505-BL each 299.95

1941-53 (3/4 ton) Pickup (right hand)

P4153-17505-BR each 299.95

Assembly (complete with stakes and side angles welded on) not just a panel - fits short Stepside only

1955-72 Pickup (left hand)

P5572-17505-A each 399.95

1955-72 Pickup (right hand)

P5572-17505-B each 399.95



NEW!

Special order

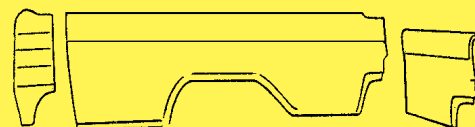

CAMEO BED SIDE KIT

Fiberglass. One piece construction and the tail light housing is molded into the bedside so all you need to buy are the lenses. The bed sides & tailgate skin bolt directly to your Stepside box tailgate.

1955-59 Cameo

P5559-17505-ASPO kit 1098.95

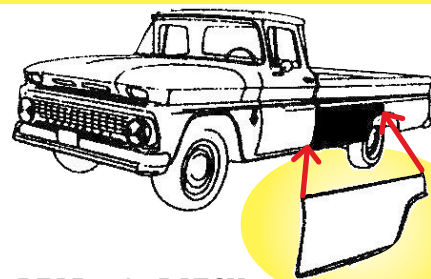

REAR 1/4 PATCH

Front of rear 1/4 panel fender section. Die stamped steel.

1960-66 Fleetside (8 ft) bed (left hand)

P6066-17505-LFRQB each 79.95

1960-66 Fleetside (8 ft) bed (right hand)

P6066-17505-RFRQB each 79.95

1967-72 Fleetside Pickup (Long wheel base) 8 ft bed may alter for 6 ft (left hand)

P6772-17505-LFRQ each 114.95

1967-72 (8 ft bed may alter for 6 ft bed) (right hand)

P6772-17505-RFRQ each 114.95

1973-78 Fleetside Pickup (short wheel base) 8 ft bed, will also fit 1979-85 by altering at gas filler (left hand)

P7378-17505-LFRQ each 114.95

1973-78 Fleetside Pickup (8 ft bed will also fit 1979-85 by altering gas filler (right hand)

P7378-17505-RFRQ each 114.95





PICKUP BED PARTS

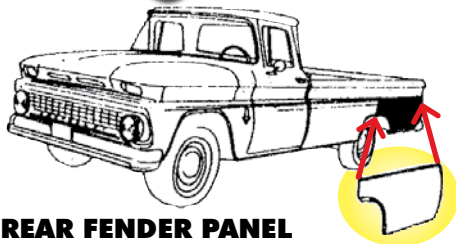

REAR FENDER PANEL

Rear of rear fender patch panel.

1960-66 Fleetside (8 ft bed) Long wheel base (left hand)

P6066-17505-LRFP each 69.95

1960-66 Fleetside (8 ft bed) (right hand)

P6066-17505-RRFP each 69.95

1967-72 Fleetside (8 ft bed) Long wheel base (left hand)

P6772-17505-LRFP each 114.95

1967-72 Fleetside (6 ft. bed) short wheel base (left hand)

P6772-17505-LRFPB each 99.95

1967-72 Fleetside (8 ft bed) (right hand)

P6772-17505-RRFP each 114.95

1967-72 Fleetside Pickup (Long wheel base) 6 ft bed (right hand)

P6772-17505-RRFPB each 99.95



COMPLETE BEDSIDE PANEL

Die stamped steel. Exact reproduction of original. **Truckline only**

1967 Chevy/GMC 6 ft. Fleetside

P67-17505-6L each 599.95

1967 Chevy/GMC 6 ft. Fleetside.

P67-17505-6R each 599.95

1968-72 Chevy/GMC 6 ft. Fleetside Pickup

P6872-17505-6L each 599.95

1968-72 Chevy/GMC 6 ft. Fleetside Pickup

P6872-17505-6R each 599.95

1973-78 Pickup (right hand, w/gas hole, 8' bed)

P7378-17505-WG each 399.95

1973-80 Pickup (right hand, w/round gas hole, 6.5' bed)

P7380-17505-WGA each 399.95

1973-80 Pickup (left hand, w/o gas hole, 8' bed)

P7380-17505-WOG each 399.95

1973-80 Pickup (left hand, w/o gas hole, 6.5' bed)

P7380-17505-WOGA each 399.95

1973-87 (Shortbed - Stepside) (left hand)

P7387-17505-LH each 399.95

1973-87 Short step (right hand)

P7387-17505-RH each 399.95

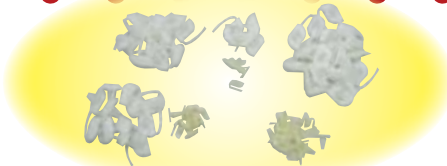

UPPER & LOWER BEDSIDE MOLDING CLIP KIT

Does upper & lower moldings, doors & fender pieces.

1962-66 Long Fleetside Pickup w/ long wheel base

P6266-17507-LK set. 34.95

1962-66 Pickup Short Fleetside

P6266-17507-SK set. 32.95



REAR WHEEL HOUSING

Die stamped steel.

1967-72 Chevrolet/ GMC Truck

1969-72 Chevrolet/ GMC Blazer

(left hand)

P6772-17505-LH each 89.95

1967-72 Chevrolet/ GMC Truck

1967-72 Chevrolet/ GMC Blazer

(right hand)

P6772-17505-RH each 119.95

1973-87 Pickup (left hand)

P7391-17505-WL each 29.95

1973-87 Pickup (right hand)

P7391-17505-WR each 29.95

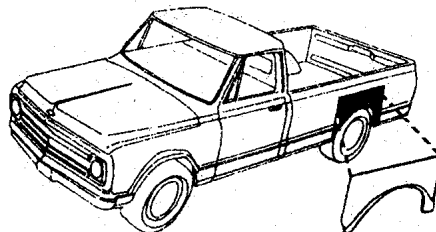

WHEEL HOUSING PANEL

Complete rear fender wheel housing panel. Die stamped steel. **NOT UPS ABLE**

1967-72 Pickup, Suburban, Blazer, Jimmy

(left hand)

P6772-17505-LWRP each 24.95

1967-72 Pickup, Suburban, Blazer, Jimmy

(right hand)

P6772-17505-RWRP each 24.95

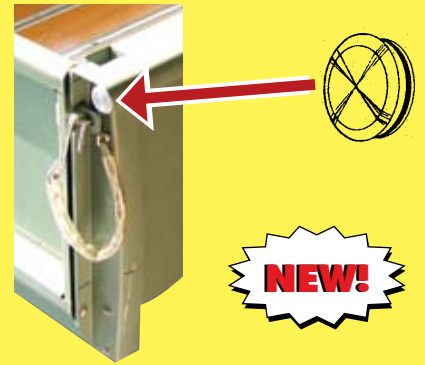

BEDSIDE HOLE CAPS

Aluminum cap for the hole in the end of your GM Stepside bed side. A rubber o-ring band lines the inside of the caps to aid in installation, and to help the caps stay in place. (satin finish) This plugs the round roll hole at the rear of each bed side panel.

1941-66 Stepside

P4166-17505-CAP pair. 34.95

1941-66 Stepside (polished)

P4166-17505-CAPP pair 34.95

1967-87 Stepside (satin finish)

P6787-17505-CAP pair. 34.95

1967-87 Stepside (polished finish)

P6787-17505-CAPP pair 34.95



MOULDING CLIP

All

Universal, snap off to fit most body mouldings.

Pkg 10 size 10 x 24 x 3/4

U-29000-CLAK set 9.95

1962-66 Fleetside

Upper body side moulding and door moulding clips

P6266-17507-CLB each 1.95

1962-66 Fleetside

Lower body side moulding clip

P6266-17507-CLA each 1.95

1967-72 Pickup

Upper rear side panel moulding clip (req. 12)

(2 tone moulding) grey nylon clip

P6772-17507-CLA each 95

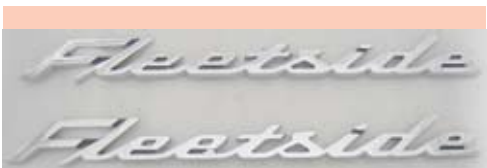

REAR QTR PANEL SCRIPT

"Fleetside"

1958-59 Pickup

P5859-17507-AS pair 119.95



1962-72 Body Mouldings

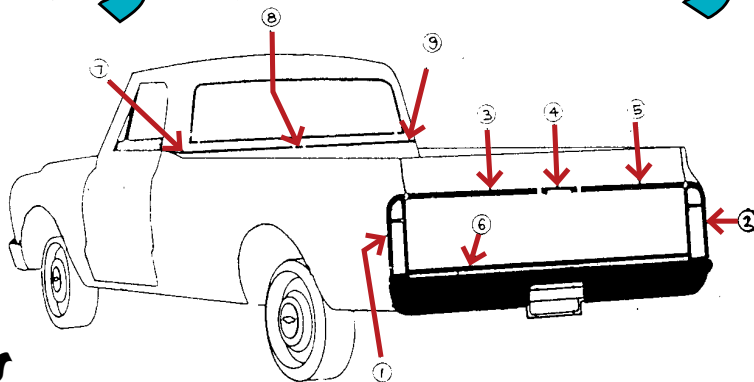
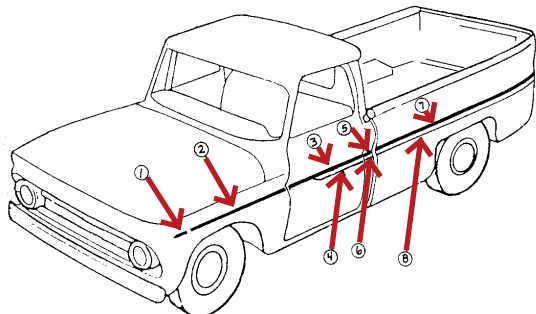

1962-66 SIDE BODY MOULDINGS

FRONT FENDER MOULDING SPEAR (1)

1962-66 Ser.10-20 (LH or RH)

P6266-8132-FFM each27.95

FRONT FENDER MOULDING (2)

1962-66 Ser.10-20 (LH or RH)

P6266-8132-RFM each34.95

UPPER DOOR MOULDING (3)

1962-66 Fleetside (LH or RH)

P6266-17507-UDM each32.95

LOWER DOOR MOULDING (4)

1962-66 Fleetside

(LH) P6266-17507-LLDM each32.95

(RH) P6266-17507-RLDM each32.95

UPPER CAB MOULDING (5)

1962-66 Fleetside

(LH) P6266-17507-UCL each9.95

(RH) P6266-17507-UCR each9.95

LOWER CAB MOULDING (6)

1962-66 Fleetside (LH or RH)

P6266-17507-LCM each7.95

UPPER BEDSIDE PANEL MOULDING (7)

1962-66 Fleetside (Short Bed) LH or RH

P6266-17507-USM each49.95

1962-66 Fleetside (Long Bed) LH or RH

P6266-17507-USMB each56.95

LOWER BEDSIDE PANEL MOULDING (8)

1962-66 Fleetside (Short Bed) LH or RH

P6266-17507-LBMA each64.95

1962-66 Fleetside (Long Bed) LH or RH

P6266-17507-LBMB each69.95

1967-72 REAR BODY MOULDINGS

TAIL LAMP BEZEL (1)

1969-72 Fleetside, Blazer

(LH) P6972-2681-AL each.....12.95

TAIL LAMP BEZEL (2)

1969-72 Fleetside, Blazer

(RH) P6972-2681-AR each.....12.95

UPPER TAILGATE MOULDING (3)

1967-72 Pickup

(LH) P6772-17615-LUM each.....14.95

CENTER TAILGATE MOULDING (4)

1967-72 Pickup

P6772-17615-CNTR each.....19.95

UPPER TAILGATE MOULDING (5)

1967-72 Pickup

(RH) P6772-17615-RUM each.....14.95

LOWER TAILGATE MOULDING (6)

1969-72 Fleetside, Blazer, w/ body side mldgs (Upper & Lower)

P6972-17215-TGM each.....29.95

REAR CAB MOULDING (7)

1967-72 Ser.10-30 (with 2 Tone Paint)

(LH) P6772-17507-URLM each.....42.95

REAR CAB MOULDING COUPLER (8)

1967-72 Pickup

P6772-17507-JC each.....7.95

REAR CAB MOULDING (9)

1967-72 Ser.10-30 (with 2 Tone Paint)

(RH) P6772-17507-URRM each.....42.95

BUY YOUR SIDE MOULDINGS AS A KIT!

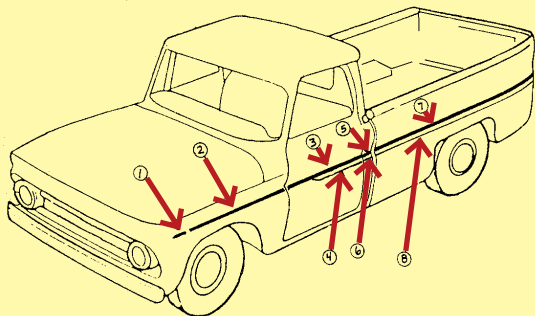

1962-66 SIDE MOULDING KIT

1962-66 Chevy (for Chevy long wide bed)

P6266-17507-CL kit449.95

1962-66 Chevy (for short wide bed)

P6266-17507-CS kit439.95

1962-66 GMC (for GMC long wide bed)

P6266-17507-GL kit269.95

1962-66 GMC (for GMC short wide bed)

P6266-17507-GS kit249.95



PICKUP BED PARTS

1967-72 Body Mouldings

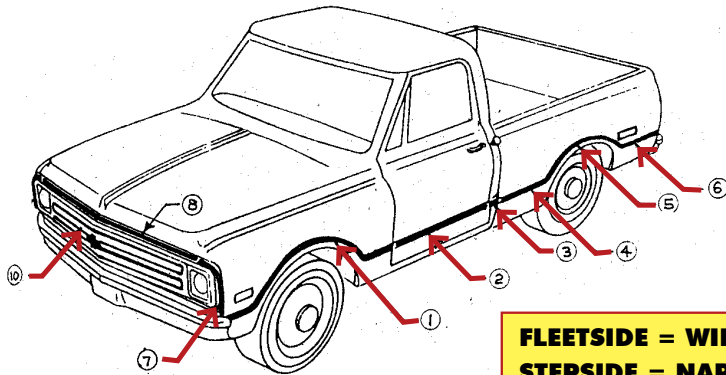

**FLEETSIDE = WIDE BED
STEPSIDE = NARROW BED**

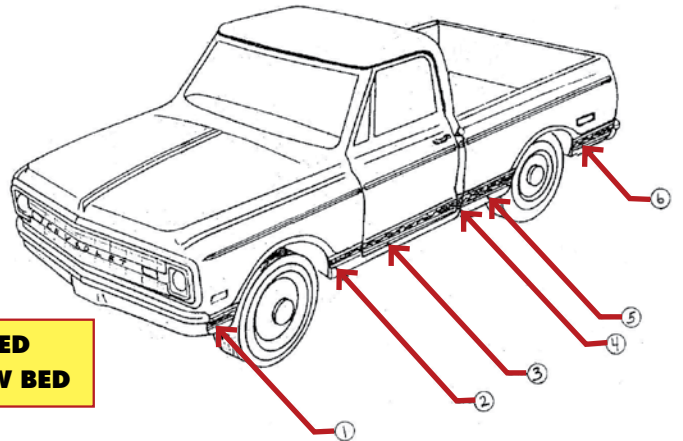

1967-68 BODY MOULDINGS

FRONT FENDER MOULDING	(1)
1967-68 Ser.10-30	
(LH) P6768-8132-LWWM each	119.95
(RH) P6768-8132-RWWM each	119.95
LOWER DOOR MOULDING	(2)
1967-68 Ser 10-30 w/ side trim	
(LH) P6768-17507-LFDM each	49.95
(RH) P6768-17507-RFDM each.....	49.95
CAB INTERMEDIATE MOULDING	(3)
1967-68 Pickup	
(LH) P6768-17507-LIM each	34.95
(RH) P6768-17507-RIM each	34.95
LOWER FRONT BED MOULDING	(4)
1967-68 Fleetside (Shortbed)	
(LH) P6768-17507-LFMS each	42.95
(RH) P6768-17507-RFMS each.....	42.95
1967-68 Fleetside (Longbed)	
(LH) P6768-17507-LFM each	49.95
(RH) P6768-17507-RFM each	49.95
REAR WHEEL WELL MOULDING	(5)
1967-68 Pickup	
(LH) P6768-17507-LWWM each	79.95
(RH) P6768-17507-RWWM each.....	79.95
LOWER REAR BED MOULDING	(6)
1967-68 Fleetside (Shortbed)	
(LH) P6768-17507-LRMB each	42.95
(RH) P6768-17507-RRMB each	42.95
1967-68 Fleetside (Longbed)	
(LH) P6768-17507-LRMA each	49.95
(RH) P6768-17507-RRMA each	49.95
FRONT FENDER MOULDING	(7)
1968 Ser.10-30 (exc. D-D)	
(LH) P68-8132-LFM each	49.95
FRONT HOOD MOULDING	(8)
1968 Ser.10-30 (exc. D-D)	
P68-8015-A each	69.95
FRONT FENDER MOULDING	(9)
1968 Ser.10-30 (exc. D-D)	
(RH) P68-8132-RFM each	49.95
RADIATOR GRILLE MOULDING	(10)
1967-68 Ser.10-30	
P6768-1268-A each.....	74.95

1969-72 LOWER WOODGRAIN BODY MOULDINGS

FRONT FENDER SIDE MOULDING	(1)
1969-72 Pickup & Blazer	
(LH) P6972-8132-LWGM each.....	34.95
(RH) P6972-8132-RWGM each.....	34.95
FRONT FENDER REAR MOLDING	(2)
1969-72 Pickup & Blazer	
(LH) P6972-8132-LRSM each.....	39.95
(RH) P6972-8132-RRSM each.....	39.95
DOOR MOULDING	(3)
1969-72 Pickup & Blazer	
(LH) P6972-17507-LLDMW each.....	39.95
(RH) P6972-17507-RLDMW each.....	39.95
CAB CORNER MOULDING	(4)
1969-72 Fleetside (with Custom sport package)	
P6972-17507-LWGM each.....	24.95
P6972-17507-RWGM each.....	24.95
FRONT BEDSIDE MOULDING	(5)
1969-72 Fleetside (Shortbed)	
P6972-17507-LFWGA each.....	34.95
P6972-17507-RFWGA each.....	34.95
1969-72 Fleetside (Longbed)	
(LH) P6972-17507-LWGB each.....	39.95
(RH) P6972-17507-RWGB each.....	39.95
1969-72 Fleetside (Longhorn)	
(LH) P6972-17507-LWGC each.....	64.95
(RH) P6972-17507-RWGC each.....	64.95
1969-72 Blazer	
(LH) P6972-17507-LWGD each.....	39.95
(RH) P6972-17507-RWGD each.....	39.95
REAR BEDSIDE MOULDING	(6)
1969-72 Blazer (Shortbed)	
(LH) P6972-17507-LWGA each.....	34.95
(RH) P6972-17507-RWGA each.....	34.95
1969-72 Fleetside (Longbed & Longhorn)	
(LH) P6972-17507-LRWGB each.....	39.95
(RH) P6972-17507-RRWGB each.....	39.95

Can't find it? Call us!

PICKUP BED PARTS

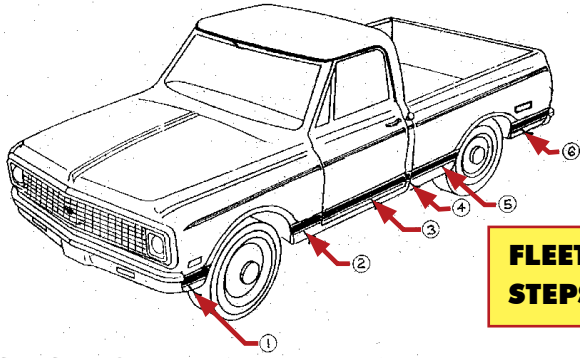

1969-72 Body Mouldings

**FLETSIDE = WIDE BED
STEPSIDE = NARROW BED**

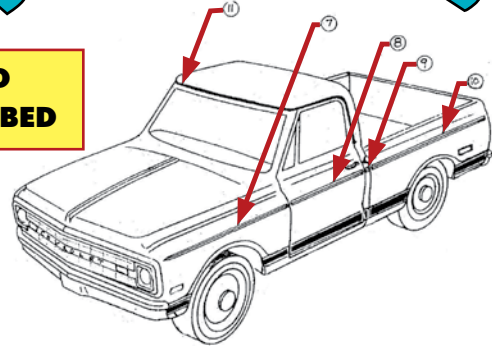

1969-72 LOWER BLACK BODY MOULDINGS

FRONT FENDER SIDE MOULDING (1)	
1969-72 Pickup & Blazer	
(LH) P6972-8132-LFLM each	34.95
(RH) P6972-8132-RFLM each	34.95
FRONT FENDER REAR MOLDING (2)	
1969-72 Pickup & Blazer	
(LH) P6972-8132-LLRM each	39.95
(RH) P6972-8132-RLRM each	39.95
DOOR MOULDING (3)	
1969-72 Pickup & Blazer	
(LH) P6972-17507-LLDM each	39.95
(RH) P6972-17507-RLDM each	39.95
CAB CORNER MOULDING (4)	
1969-72 Fleetside	
(LH) P6972-17507-LLIM each	29.95
(RH) P6972-17507-RLIM each	29.95
FRONT BEDSIDE MOULDING (5)	
1969-72 Fleetside (Shortbed)	
(LH) P6972-17507-LFMA each	29.95
(RH) P6972-17507-RFMA each	29.95
1969-72 Fleetside (Longbed)	
(LH) P6972-17507-LFMB each	29.95
(RH) P6972-17507-RFMB each	29.95
1969-72 Fleetside (Longhorn)	
(LH) P6972-17507-LFMC each	44.95
(RH) P6972-17507-RFMC each	44.95
1969-72 Blazer	
(LH) P6972-17507-LFMD each	32.95
(RH) P6972-17507-RFMD each	34.95
REAR BEDSIDE MOULDING (6)	
1969-72 Fleetside (Shortbed) & Blazer	
P6972-17507-LRMA each	29.95
P6972-17507-RRMA each	29.95
1969-72 Fleetside (Longbed & Longhorn)	
(LH) P6972-17507-LRMB each	34.95
(RH) P6972-17507-RRMB each	34.95

1969-72 UPPER BODY MOULDINGS

UPPER FRONT FENDER MOULDING (7)	
1969-72 Pickup (Fits LH or RH)	
P68-8132-UPSM each	36.95
UPPER DOOR MOULDING (8)	
1969-72 Pickup	
(LH) P6972-17507-LDM each	39.95
(RH) P6972-17507-RDM each	39.95
UPPER CAB CORNER MOULDING (9)	
Fits behind door and between cab	
1969-72 Pickup Fleetside	
(LH) P6972-17507-LUISM each	29.95
(RH) P6972-17507-RUISM each	29.95
UPPER BEDSIDE MOULDING (10)	
(LH or RH)	
1969-72 Fleetside (Shortbed)	
P6972-17507-USPMA each	59.95
1969-72 Fleetside (Longbed)	
P6972-17507-USPMB each	69.95
1969-72 Fleetside (Longhorn)	
P6972-17507-USPM9 each	79.95
DRIP RAIL STAINLESS STEEL MOULDING SET (11)	
Fits above windshield.	
1969-72 Pickup	
P6772-16000-DR set	169.95

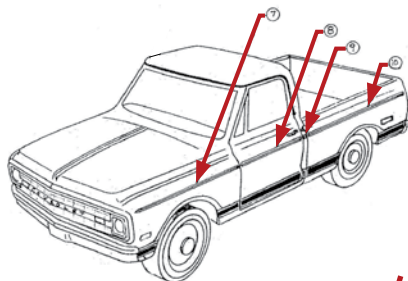
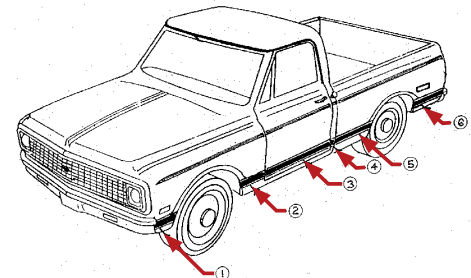

**BUY YOUR SIDE
MOULDINGS
AS A SET!**

UPPER MOLDING SET

1969-72 Chevy/GMC Short Fleetside	
P6972-17507-U6 8 piece set	299.95
1969-72 Chevy/GMC Long Fleetside Pickup	
P6972-17507-U8 8 piece set	314.95

LOWER WOODGRAIN MOLDING SET

Complete with mounting clips.	
1969-72 Chevy/GMC Short Fleetside Pickups	
P6972-17507-LW6 set	349.95
1969-72 Chevy/GMC 8 ft. Longbed Fleetside	
P6972-17507-LW8 set	374.95

LOWER MOLDING SET W/BLACK INSERT

Complete for both sides.	
1969-72 short bed Fleetside	
P6972-17507-LB6 set	299.95
1969-72 8ft. long bed Fleetside with 127" wheelbase	
P6972-17507-LB8 set	324.95



PICKUP BED PARTS

1973-80 Body Mouldings

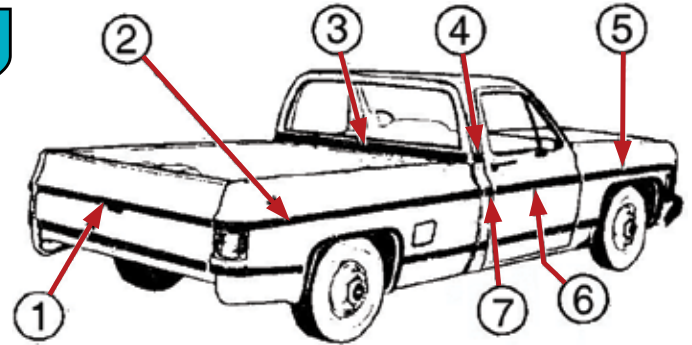
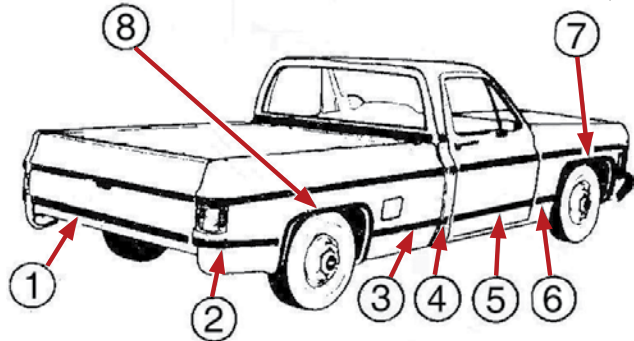

1973-80 LOWER BODY MOULDINGS

TAILGATE MOULDING (1)	
1973-76 Ser.10-30 Pickup, Blazer, Jimmy	
1979-80 Suburban (Flts upper and lower)	
P7380-17215-A each	24.95
LOWER REAR BEDSIDE MOULDING (2)	
1973-80 Pickup (Shortbed)	
(LH) P7380-17507-LRL each	14.95
(RH) P7380-17507-LRR each	14.95
1973-80 Pickup (Longbed)	
(LH) P7380-17507-RLH each	16.95
(RH) P7380-17507-RRH each	16.95
LOWER FRONT BEDSIDE MOULDING (3)	
1973-80 Pickup (Shortbed)	
(LH) P7380-17507-LFL each	14.95
(RH) P7380-17507-LFR each	14.95
1973-80 Pickup (Longbed)	
(LH) P7380-17507-LH each	14.95
(RH) P7380-17507-RH each	14.95
1973-80 Blazer, Jimmy	
(LH) P7380-17507-FLH each	14.95
(RH) P7380-17507-FRH each	14.95
CAB SIDE MOULDING (4)	
(LH or RH) Upper or Lower	
1978 Ser.10-30 4 Door Pickup & Suburban	
1973-80 Pickup	
P7380-17507-A each	6.95
FRONT DOOR LOWER MOULDING (5)	
1973-76 Ser.10-30, Blazer, Jimmy	
1978-80 Ser.10-30	
(LH) P7380-17507-LLH each	16.95
(RH) P7380-17507-LRH each	16.95
LOWER REAR FRONT FENDER MOULDING (6)	
1973-80 Ser.10	
(LH) P7380-8132-LL each	9.95
(RH) P7380-8132-LR each	9.95
FRONT WHEEL WELL OPENING MOULDING (7)	
1973-80 Ser.10	
(LH) P7380-8132-FL each	11.95
(RH) P7380-8132-FR each	11.95
REAR WHEEL WELL OPENING MOULDING (8)	
1973-87 Pickup	
(LH) P7387-17507-LH each	12.95
(RH) P7387-17507-RH each	12.95

1973-80 UPPER BODY MOULDINGS

TAILGATE MOULDING (1)	
1973-76 Ser.10-30 Pickup, Blazer, Jimmy	
1979-80 Suburban	
P7380-17215-A each	24.95
BED SIDE UPPER MOULDING (2)	
1973-80 Suburban	
(LH) P7376-17507-BLC each	44.95
(RH) P7376-17507-BRC each	44.95
1973-80 (2wd, 4wd, Ser. 10 (117.5 W.B.) (left hand)	
P7380-17507-BLA each	24.95
1973-80 Pickup (6.5 ft) (right hand)	
P7380-17507-BRA each	24.95
1973-80 Blazer (left hand) quarter trim	
P7380-17507-BLB each	39.95
1973-80 Blazer (right hand) upper 1/4 trim molding	
P7380-17507-BRB each	39.95
1973-80 Pickup (8 ft) (left hand)	
P7380-17507-BLE each	26.95
1973-80 Pickup (8 ft) (right hand)	
P7380-17507-BRC each	26.95
CAB REAR UPPER APPLIQUE MOULDING (3)	
(Paint as required - black background)	
1973-76 Ser.10-30 with cab applique	
1978 Ser.10-30 with cab applique	
1979-80 Ser.10-30 with exterior ornament	
P7378-17507-A each	89.95
REAR CAB CORNER APPLIQUE MOULDING (4)	
1974-76 GMC Ser.10-30 w/ cab applique	
1978 GMC Ser.10-30 w/ cab applique (GMC)	
1979-80 GMC Ser.10-30 w/ exterior ornament (exc camper)	
(LH) P7380-17507-LHG each	39.95
(RH) P7380-17507-RHG each	39.95
1973-78 Chevrolet Ser.10-30 w/ cab applique	
1979-80 Chevrolet Ser.10-30 w/ exterior ornament (exc camper)	
(LH) P7378-17507-LH each	54.95
(RH) P7378-17507-RH each	79.95
UPPER FRONT FENDER MOULDING (5)	
1973-80 Ser.10 (2WD)	
(LH) P7380-8132-UL each	26.95
(RH) P7380-8132-UR each	26.95
FRONT DOOR UPPER MOULDING (6)	
1973-76 Ser.10-30, Blazer, Jimmy	
1973-80 Ser.10-30 w/ belt reveal	
(LH) P7380-17507-ULH each	14.95
(RH) P7380-17507-URH each	14.95
CAB SIDE MOULDING (7)	
1973-80 Pickup & Suburban (LH or RH)	
P7380-17507-A each	6.95

PICKUP BED PARTS



TAILLIGHT BEZEL & UPPER TAILGATE MOULDING CLIP

1967-72 Pickup
1969-72 Blazer
P6772-17507-MC each 1.95

1967-72



1968-72

BODY SIDE MOULDING RETAINER

Tail gate moulding (upper & lower) clip retainers.
1967-72 Fleetside
1969-72 Blazer
P6872-17507-RA each 1.95
1968-72 Fleetside
P6872-17507-RB each 2.95

REAR QUARTER PANEL UPPER MOULDING STUD

(req. 12)
1967-72 Ser 10-30 (cab)
P6772-17507-ST each 1.95



1969-70 Shortbed

1969-70 Longhorn

UPPER BED MOULDING CLIP KIT

Push-in and screw type, fits either side. Requires 2
1969-70 Pickup (Shortbed - 6')
P6970-17507-UB6MK kit 13.95
1969-70 Pickup (Longbed - 8')
P6970-17507-UB8MK kit 15.95
1969-70 Longhorn Pickup (Longhorn - 9')
P6970-17507-UB9MK each 16.95

UPPER DOOR MOULDING CLIP KIT

1969-70 Pickup
P6970-17507-UDMK kit 5.95
1971-72 Pickup
P7172-17507-UDMK kit 5.95



Sierra Grande

"SIERRA" REAR 1/4 PANEL EMBLEM

1969-72 GMC Pickup ("Sierra Grande")
P6972-17507-GAS pair 119.95
1969-72 GMC Pickup ("Sierra")
P6972-17507-GBS pair 109.95

LOWER CAB MOLDING CLIP KIT

Fits either side.
Push-in & screw type clip. (requires 2)
1969-72 Pickup
P6972-17507-LCC kit 5.95



LOWER FRONT BEDSIDE MOLDING CLIP KIT

Fits either side. Push-in & screw type clips. (requires 2)
1969-72 Fleetside (Longbed - 8')
P6972-17507-LFLB kit 18.95
1969-72 Fleetside (Longhorn - 9')
P6972-17507-LFLH kit 19.95
1969-72 Fleetside (Shortbed - 6')
P6972-17507-LFSB kit 15.95

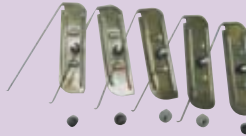

COMPLETE LOWER MOLDING CLIP KIT

Push-in & screw type clips.
1969-72 Chevy Pickup Long Fleetside (for longbeds)
P6972-17507-LLB set 99.95
1969-72 Fleetside (Longhorn - 9') (for longhorns)
P6972-17507-LLH kit 119.95
1969-72 Pickup Short Fleetside (for shortbeds)
P6972-17507-LSB set 89.95

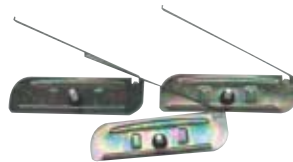

LOWER REAR BEDSIDE MOLDING CLIP KIT

Fits either side. Push-in & screw type clips. (requires 2)
1969-72 Fleetside (Longbed & Longhorn 8'-9')
P6972-17507-LRLB kit 12.95
1969-72 Fleetside (Shortbed - 6')
P6972-17507-LRSB kit 5.95

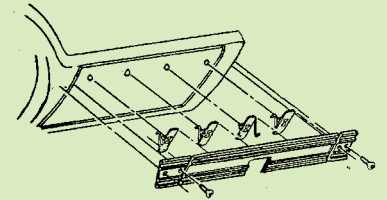

TOOL BOX DOOR MOULDING

1969-72 Chevy/GMC Pickup (Black insert)
P6972-17507-TC each 82.95
1969-72 Chevy/GMC Pickup (woodgrain insert)
P6972-17507-TCW each 99.95



FRONT OF TOOL DOOR MOULDING

Between tool box door and bed front.
1969-72 Chevy/GMC Pickup (Fits all w/ 8 ft bed, black insert)
P6972-17507-TF8 each 42.95
1969-72 Chevy/GMC Pickup, (Fits all w/ 8 ft bed, woodgrain insert)
P6972-17507-TF8W each 49.95
1969-72 Longhorn Pickup (Fits all with 9ft. bed, black insert)
P6972-17507-TF9 each 49.95
1969-72 Longhorn Pickup (Fits all 9ft beds w/ woodgrain insert)
P6972-17507-TF9W each 56.95



REAR OF TOOL BOX MOLDING

Between tool box and wheel well.
1969-72 Chevy/GMC (black insert)
P6972-17507-TR each 42.95
1969-72 Chevy/GMC (woodgrain insert)
P6972-17507-TRW each 49.95



UPPER MOULDING CLIP

Used where nut can be threaded on from back side.
1969-72 Pickup, Blazer
P6972-17507-U each 95

FLEETSIDE = WIDE BED
STEPSIDE = NARROW BED



Longhorn

"LONGHORN" REAR QUARTER FENDER EMBLEMS

1969-72 Pickup
P6972-17507-AS pair 119.95



PICKUP BED PARTS



COMPLETE UPPER MOLDING CLIP KIT

- Push-in & screw type clips.
1968-70 Fleetside (Shortbed - 6')
- P6972-17507-UCLP6 kit39.95**
1968-70 Fleetside (Longbed - 8')
- P6972-17507-UCLP8 kit44.95**
1968-70 Fleetside (Longhorn - 9')
- P6972-17507-UCLP9 kit49.95**
Adhesive back clips
1971-72 Fleetside (Shortbed - 6')
- P7172-17507-UCLP6A kit39.95**
1971-72 Fleetside (Longbed - 8')
- P7172-17507-UCLP8A kit44.95**
1971-72 Fleetside (Longhorn - 9')
- P7172-17507-UCLP9A kit49.95**



UPPER CAB MOULDING CLIP KIT

- Push-in and screw clips, fits either side.
1969-72 Pickup
- P6972-17507-UCMK kit2.95**



COMPLETE LOWER MOLDING CLIP SET

- Adhesive type clips.
1971-72 Longhorn Pickups
- P7172-17507-L9B set99.95**
1971-72 Chevy/GMC Shortbed Pickup
- P7172-17507-LSB set79.95**
1971-72 Chevy Longbed Pickup
- P7172-17507-LLB set89.95**

LOWER FRONT OF BED MOLDING CLIP KIT

- Fits either side. Adhesive clips. (requires 2)
1971-72 Fleetside (Longbed - 8')
- P7172-17507-LMCL kit18.95**
1971-72 Fleetside (Longhorn - 9')
- P7172-17507-LMCLH kit19.95**
1971-72 Pickup (Shortbed)
- P7172-17507-LMCS kit15.95**

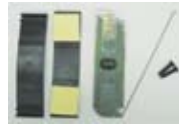

LOWER REAR BEDSIDE MOLDING CLIP KIT

- Fits either side. Adhesive clips. (requires 2)
1971-72 Fleetside (Longbed-Longhorn 8'- 9')
- P7172-17507-LRMCL kit12.95**
1971-72 Fleetside (Shortbed - 6')
- P7172-17507-LRMCS kit5.95**



MOULDING CLIP

- With rubber sealing ring on 3/4" stud - 4 3/8" clip. These won't fall off like GM's do.
1971-72 Ser. 10-30 & Blazer lower body side moulding
1972 Fleetside upper side panel moulding - side door moulding & front door moulding
- P7172-17507-RA each1.95**

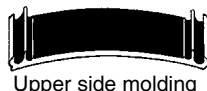

Upper side molding



Tool & storage moulding

RETAINER

- 1971-72 Fleetside
Upper side molding & upper door moulding.
- P7172-17507-RB each5.95**
1971-72 Fleetside
Tool & storage compartment door moulding retainer (req. 4)
- P7172-17507-RC each9.95**



UPPER BED MOULDING CLIP KIT

- Adhesive back clips, fits either side. (requires 2)
1971-72 Shortbed Pickup
- P7172-17507-UB6MK kit9.95**
1971-72 Pickup (Longbed - 8")
- P7172-17507-UB8MK set11.95**
1971-72 Longhorn Pickup
- P7172-17507-UB9MK kit15.95**



RETAINER ASSEMBLY

- 1973-78 (2wd, 4wd, Ser. 10-30 (w/ body side moulding upper)
1980 (2wd, 4wd, Ser. 10-30)
Lower rear front door, end gates body side upper front, side rear doors (adhesive type)
- P7378-17507-RB each1.95**
1973-80 (2wd, 4wd, Ser. 10-30 (w/ body side mouldings)
Front fender upper or lower, body side or side rear door lower.
- P7378-17507-RA each4.95**
1973-80 (2wd, 4wd, Ser. 10-30 (Cab) w/ cab back panel applique & moulding)
Rear outer panel (upper rear moulding)
- P7378-17507-RC each4.95**
1973-80 (2wd, 4wd, Ser. 10-30 w/ cab back panel applique and moulding)
Corner, rear outer panel upper
- P7378-17507-RD each4.95**



SIDE REAR NAME DECAL

- "Big 10"
1979-80 (2wd, Ser. 10 w/ h.d.c. (Chevy)
- P7980-17507-AB each34.95**



HIGH SIERRA NAME PLATE

- For rear body.
1980-82 (2wd, 4wd, (Suburban) Silverado/Sierra classic (GMC)
- P8082-17507-BJ each39.95**



SILVERADO NAME PLATE

- For rear body.
1980-84 (2wd, 4wd, Ser. 10 (Suburban) w/ Silverado/Sierra Classic (GMC)
- P8084-17507-BJ each46.95**

See our current
swap meet
schedule inside the back cover!
See ya there!

PICKUP BED PARTS



1934-38



1940 Chevy



1947-53 'Chevrolet'



1947-53 'GMC'

SCRIPT TAILGATE

Includes rolling script as original. Die stamped steel.
1934-38 Chevy Pickup ('Chevy')

P3438-17615-S each299.95

1934-39 GMC ('GMC' script as original)

P3439-17615-G each369.95

1939 Chevy Pickup ('Chevrolet')

P39-17615-S each299.95

1940 GMC only ('GMC')

P40-17615-GS each369.95

1940 Chevy Pickup ('Chevrolet')

P40-17615-S each299.95

1941-46 GMC only ('GMC')

P4146-17615-GS each369.95

1947-53 GMC Pickup ('GMC')

P4753-17615-G each249.95

1947-53 Chevy Pickup ('Chevrolet')

P4753-17615-S each249.95



BOWTIE TAILGATE

Die stamped steel tailgate.
1947-53 Stepside (with embossed bow-tie in center, Stepside box)

P4753-17615-EBT each199.95

1954-87 Stepside (with embossed bow-tie in center)

P54U-17615-EBT each249.95

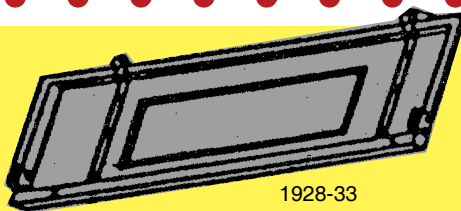

1928-33

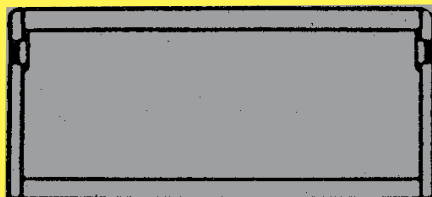

1934-38

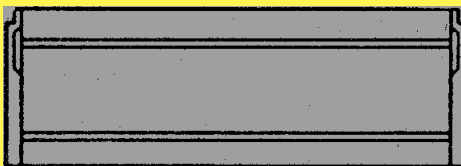

1941-46

PLAIN TAILGATE ASSEMBLY

Steel tailgate. Like original but does not say "Chevrolet".

1928-33 Pickup

P2833-17615-PL each299.95

1934-39 Chevy Pickup

P3438-17615-P each269.95

1940 Chevy Pickup

P40-17615-P each279.95

1941-46 Chevy Pickup

P4146-17615-P each219.95

1954-87 Chevy Stepside

P5472-17615-PL each189.95



SMOOTH STEPSIDE TAILGATE ASSEMBLY

1941-46 Chevy Stepside

P4146-17615-SM each179.95

1947-53 Chevy Stepside

P4753-17615-SM each179.95

1954-87 Chevy Stepside

P54U-17615-SM each179.95



GMC STAMPED STEPSIDE TAILGATE

1954-87 GMC Stepside

P5487-17615-G each249.95

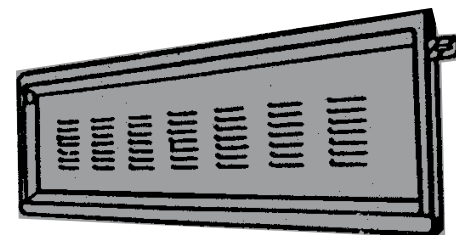

LOUVERED TAILGATE ASSEMBLY

7-row louvered tailgate assy.

1941-46 Stepside

P4146-17615-L7 each249.95

1947-53 (Stepside)

P4753-17615-L7 each249.95

1954-87 Chevy Stepside

P54U-17615-L7 each249.95

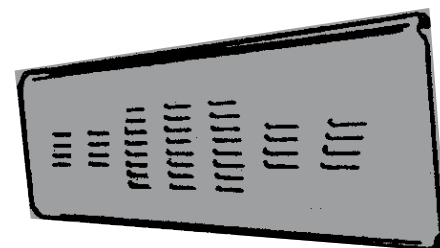

BOWTIE LOUVER TAILGATE ASSEMBLY

Louvers create a bowtie shape.

1954-87 Chevy Stepside

P54U-17615-LBT each279.95



1958-66, 'Chevrolet'



1958-66, 'GMC'

FLEETSIDE TAILGATE WITH BLOCK LETTERS

EDP black

1958-66 Chevy Pickup ('Chevrolet')

P5866-17615-CHV each369.95

1955-66 GMC Pickup ('GMC')

P5866-17615-GMC each369.95

FLEETSIDE = WIDE BED
STEPSIDE = NARROW BED



PICKUP BED PARTS



1958-66

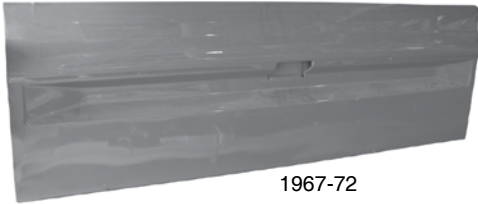

1967-72

TAILGATE ASSEMBLY

- 1954-72 Pickup
Stamped Chevrolet as original, fits Stepside only. (50-3/4" wide)
- P5472-17615-A each249.95**
1958-66 Fleetside
Plain (no letters) EDP black
- P5866-17615-A each329.95**
1967-72 Chevy/GMC Pickup
1969-72 Blazer
Replacement style (not stamped Chevrolet)
Handle and latch not included, correct thickness, not the light weight gate previously available.
- P6772-17615-A each189.95**
1973-76 Fleetside (cab) Blazer (exc rem. hard top) (Chevy only) Chevrolet name in center of gate, not complete.
- P7376-17185-A each224.95**
1973-84 Fenderside (GMC Only)
- P7378-17185-B each298.95**
1973-80 Pickup (Not UPS able)
- P7380-17615-A each99.95**



1967-72 Chevy



1967-72 GMC

FLEETSIDE ORIGINAL STYLE TAILGATE WITH EMBOSSED LETTERING

- 1967-72 Chevy Fleetside Pickup and Blazer ("Chevrolet")
- P6772-17615-CHV each349.95**
1967-72 GMC Fleetside Pickup, Jimmy ("GMC")
- P6772-17615-GMC each349.95**

TAILGATE COVERS

Die stamped steel. This is a full cover, designed to bolt or weld onto your existing pickup tailgate. This is an easy way to refresh the look of your beat up tailgate at HALF THE COST of a new one.

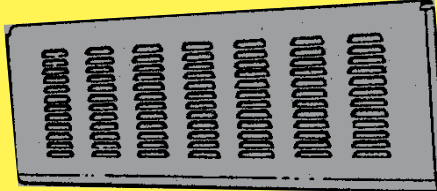
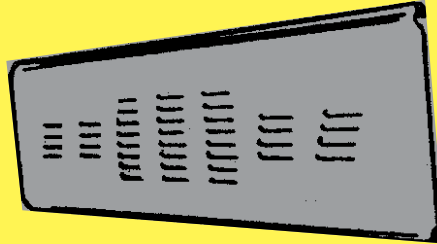

LOUVERED TAILGATE COVER

- Die stamped steel, *outer cover only.*
- 1947-53 Chevy Stepside (Bowtie louvered)
P4753-17615-CBT each94.95
- 1947-53 Chevy Stepside (4-row louvered)
P4753-17615-CL4 each69.95
- 1947-53 Chevy (7-row louvered)
P4753-17615-CL7 each69.95
- 1954-87 Chevy Pickup (Bowtie louvered)
P54U-17615-CBT each94.95
- 1954-87 Chevy (Stepside) (4-row louvered)
P54U-17615-CL4 each69.95
- 1954-87 Chevy Pickup (7-row louvered)
P54U-17615-CL7 each69.95
- 1958-66 Chevy Fleetside Pickup (Bowtie louvered)
P5866-17615-CBT each159.95
- 1958-66 Chevy Fleetside Pickup (4-row louvered)
P5866-17615-CL4 each126.95
- 1958-66 Chevy Pickup (9-row louvered)
P5866-17615-CL9 each139.95
- 1967-72 Chevy Pickup (Bowtie louvered)
P6772-17615-CBT each159.95
- 1967-72 Chevy (Fleetside) (4-row louvered)
P6772-17615-CL4 each126.95
- 1967-72 Chevy Fleetside Pickup (9-row louvered)
P6772-17615-CL9 each139.95
- 1973-87 Fleetside (9-row louvered)
P7387-17615-CL9 each179.95
- 1973-87 Fleetside (4-row louvered)
P7387-17615-CLH each129.95

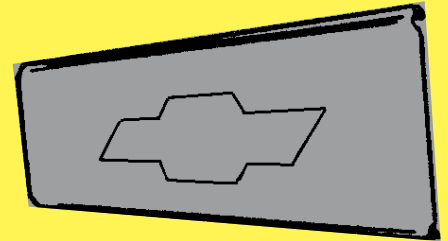

EMBOSSED 'BOWTIE' TAILGATE COVER

- Die stamped steel, *outer cover only.*
- 1954-87 Stepside
P5487-17615-BT each89.95
- 1958-66 Fleetside
P5866-17615-BT each142.95
- 1967-72 Fleetside
P6772-17615-BT each142.95
- 1973-80 Fleetside
P7380-17615-BT each142.95
- 1947-53 Stepside
P4753-17615-BT each89.95
- 1973-80 Fleetside
P7387-17615-BT each159.95
- 1941-46 Stepside
P4146-17615-BT each89.95

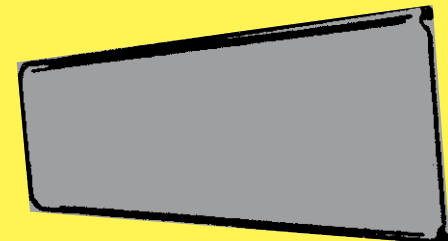

SMOOTH TAILGATE COVER

- Die stamped steel, *outer cover only.*
- 1947-53 Chevy Pickup
P4753-17615-CSM each54.95
- 1954-87 Chevy Pickup
P54U-17615-CSM each54.95
- 1958-66 Chevy Fleetside Pickup
P5866-17615-CSM each109.95
- 1967-72 Chevy Pickup
P6772-17615-CSM each109.95
- 1973-87 Fleetside
P7387-17615-CSM each139.95

UPPER TAILGATE MOLDING CLIP

- (5/8" bolt) 1 on each end.
1967-72 Pickup
P6772-17615-UTMC each1.95



TAILGATE TO BED BUMPER SET

- (4pc. set)
1967-72 Pickup
P6772-17615-BM set10.95

PICKUP BED PARTS



REPLACEMENT STYLE TAILGATE FOR FLEETSIDE PICKUP/BLAZER

Does not have Chevrolet stamping, not original gauge steel.
1967-72 Chevy/GMC Fleetside Pickup/Blazer
P6772-17615-R each 129.95

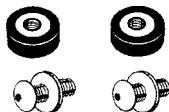

URETHANE TAILGATE TRUNION

Reduces rust and noise, stainless steel bolts and washers included.
1954-87 Pickup
P5487-17615-UT pair 36.95



CAMEO TAILGATE EMBLEM

Chrome and red bow tie.
1955-58 Cameo Pickup
P5558-17615-C each 199.95



TAILGATE TRIM CLIP SET

Contains end clips, nuts, as well as push-in clips.
1967-68 Pickup
P6768-17615-TC set 7.95
1969-72 Pickup
P6972-17615-TC set 12.95

FLEETSIDE = WIDE BED
STEPSIDE = NARROW BED



TAILGATE PROTECTOR

Chrome plated, fits over top edge of tailgate.
1954-87 Chevy/GMC Stepside Pickup
P5487-17615-TP each 39.95
1967-72 Pickup Fleetside
P6772-17615-TP each 39.95



1969-72, woodgrain

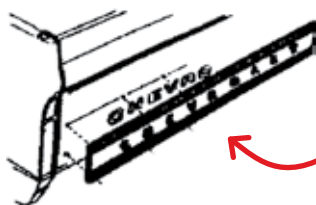

TAILGATE BAND APPLIQUE

Woodgrain .
1969-72 Pickup ('Chevrolet')
P6972-17615-ATB each 179.95
1969-72 GMC Pickup ('GMC')
P6972-17615-BTB each 199.95
Black and chrome.
1969-72 Chevy Pickup/Blazer ('Chevrolet')
P6972-17615-CTB each 179.95
1969-72 GMC Pickup/Jimmy ('GMC')
P6972-17615-DTB each 199.95



TAILGATE WEATHERSTRIP

1973-84 Blazer, Jimmy (w/ removable hard top)
P7378-17185-W each 89.95
1975-84 (2wd, 4wd, Ser. 10/20, Suburban)
Upper, mounted on top of end gate, (cap type weatherstrip, left hand)
P7578-17185-LH each 29.95
1976-81 Blazer, Jimmy (w/ soft folding top)
P7678-17185-A each 29.95

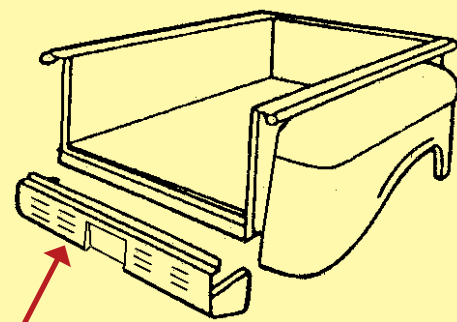

LOUVERED REAR ROLL PAN

Bolt-on or weld-on style. Die formed to match the contours of your truck for the perfect fit. These are available with or without the license plate box. **Note: This replaces your rear bumper.
1947-53 Chevy/GMC 1/2 ton Pickup
7 row louvered/no box for license plate. Steel construction.

- P4753-17616-7LNB each 119.95**
- 1947-53 Chevy Pickup, Fleetside
4-row louvered (w/ box indentation for license plate)
- P4753-17616-L4B each 159.95**
- 1947-53 Chevy Pickup
4-row louvered (no box indentation for license plate)
- P4753-17616-L4NB each 99.95**
- 1954-87 Chevy Pickup
4-row louvered (w/ boxed indentation for license plate)
- P5487-17616-L4B each 159.95**
- 1954-87 Chevy Pickup
4-row louvered (no box)
- P5487-17616-L4NB each 99.95**
- 1954-87 Chevy Pickup
7-row louvered (no box)
- P5487-17616-L7NB each 119.95**
- 1958-59 Chevy Pickup
4-row louvered (no box)
- P5859-17616-L4NB each 99.95**
- 1958-95 Chevy Pickup
9-row louvered (no box)
- P5859-17616-L9NB each 119.95**
- 1960-66 Chevy Pickup
4-row louvered (w/boxed indentation for license plate)
- P6066-17616-L4B each 159.95**
- 1960-66 Chevy Pickup (4-row louvered (no box)
- P6066-17616-L4NB each 99.95**
- 1960-66 Chevy Pickup
6-row louvered (w/box indentation for license plate)
- P6066-17616-L6B each 169.95**
- 1960-66 Chevy Pickup (9-row louvered (no box)
- P6066-17616-L9NB each 119.95**
- 1967-72 Chevy Pickup
4-row louvered (w/boxed indentation for license plate)
- P6772-17616-L4B each 159.95**
- 1967-72 Chevy Pickup (4-row louvered (no box)
- P6772-17616-L4NB each 99.95**
- 1967-72 Chevy Pickup (9-row louvered (no box)
- P6772-17616-L9NB each 119.95**
- 1973-87 Fleetside (4 row louvers, w/box)
- P7387-17616-L4B each 159.95**
- 1973-87 Fleetside (4 row louvered, w/o box)
- P7387-17616-L4NB each 99.95**
- 1973-87 Fleetside (6 row louvers, w/box)
- P7387-17616-L6B each 169.95**
- 1973-87 Fleetside (9 row louvers, w/o box)
- P7387-17616-L9NB each 119.95**



PICKUP BED PARTS

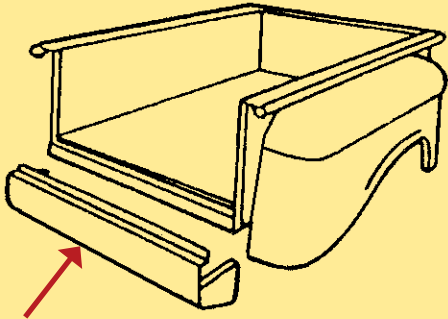

SMOOTH REAR ROLL PAN

Bolt-on or weld-on style. Die formed to match the contours of your truck for the perfect fit. These are available with or without the license plate box. **Note: This replaces your rear bumper. Steel construction.

- 1947-53 Chevy Pickup (with box indentation for license plate)
P4753-17616-SMB each139.95
- 1947-53 Chevy Pickup (no boxed indentation for license plate)
P4753-17616-SMNB each89.95
- 1954-87 Chevy Pickup (with boxed indentation for license plate)
P5487-17616-SB each139.95
- 1954-87 Long Step (w/box)
P5487-17616-SBL each139.95
- 1954-87 Chevy Pickup (no box)
P5487-17616-SNB each89.95
- 1954-87 Longstep (w/o box)
P5487-17616-SNBL each89.95
- 1958-59 Chevy Pickup (with boxed indentation for license plate)
P5859-17616-SB each149.95
- 1958-59 Chevy Pickup (no box)
P5859-17616-SNB each89.95
- 1960-66 Chevy Pickup (with boxed indentation for license plate)
P6066-17616-SB each139.95
- 1960-66 Chevy Pickup (no box)
P6066-17616-SNB each89.95
- 1967-72 Chevy Pickup (with boxed indentation for license plate)
P6772-17616-SB each139.95
- 1967-72 Chevy Pickup (no box)
P6772-17616-SNB each89.95
- 1973-87 Fleetside (w/box)
P7387-17616-SB each139.95
- 1973-87 Fleetside (w/o box)
P7387-17616-SNB each89.95

ROLL PAN REAR TAG LIGHTS

- 1947-72 Pickup
P4772-17616-TL pair49.95

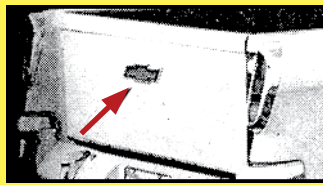

CAMEO TAILGATE SKIN

Super high quality! Outer skin only, fiberglass. 1955-58 Cameo Pickup
P5558-17615-CS each249.95



TAILGATE HOOKS

- 1934-53 Pickup (rolled iron rod, left hand)
P3453-17635-THL each5.95
- 1934-53 Pickup (rolled iron rod, right hand)
P3453-17635-THR each5.95
- 1958-66 Pickup (zinc plated)
P5866-17635-AS each7.95
- 1958-66 Fleetside (stainless steel)
P5866-17635-SSA each19.95

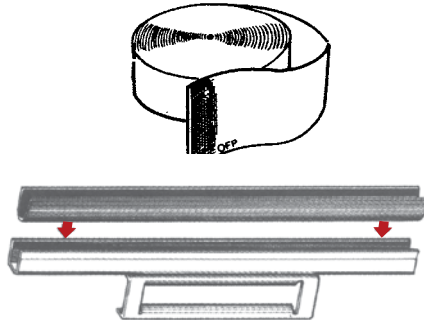

GLASS SETTING TAPE

- This is the cork-like material used for setting the glass into the door or window channel.
(20' roll X 1" wide, 1/32" thick)
B-37001-A roll14.95
(20' roll X 1" wide, 1/16" thick)
B-37001-B roll15.95



Order with confidence!

CHEVROLET Ave.

WE USE Genuine CHEVROLET PARTS

CHEVROLET PARKING ONLY

CHROME POLISH

Plastic and Emblem Adhesive

WE USE Genuine CHEVROLET PARTS

GAS TANK ETCH

MR. BUFFER

Find these great items in our Accessories & Decals section!



COMPLETE WIRING HARNESS

Built to factory specs with additional wiring for turn signals and options. 1954-55
Made by one of the



top wiring manufactures in the U.S.A - Complete with diagram to show you exactly where each wire goes. Some harnesses will signify turn signals & options - this indicates that additional wiring is included for turn signals and options that may or may not have been available on your truck.

- 1947-49 Pickup
P4749-80000-AS each239.95
- 1950-53 Pickup
P5053-80000-AS each239.95
- 1954-55 Pickup (For original 6 volt design)
P5455-80000-AS each239.95
- 1955-56 Pickup (6 cyl)
P5556-80000-AS each299.95
- 1955-56 Pickup
P5556-80000-BS set.299.95
- 1957 Pickup (6 cyl)
P57-80000-AS set.299.95
- 1957 Pickup
P57-80000-BS set.299.95
- 1958-59 Pickup (6 cyl)
P5859-80000-AS set.299.95
- 1958-59 Pickup (8 cyl)
P5859-80000-B set.299.95

WOVEN WIRE LOOM

5/16 diameter. Antique style fabric covered loom. This encompasses your wire through the truck. (30ft. roll)

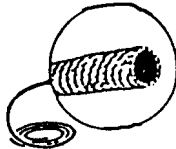

- B-80000-WWL roll7.95**
- 7/8" diameter. Great for covering wiring harnesses and battery cables. Sold by the foot.
- B-80000-7/8 foot.95**

A/C WIRING HARNESS

- 1962-63 Pickup
P6263-80005-A each106.95
- 1964 Pickup
P64-80005-A each106.95
- 1965-66 Pickup
P6566-80005-A each106.95
- 1967 Pickup
P67-80005-A each109.95
- 1968 Pickup
P68-80005-A each109.95
- 1969-70 Pickup
P6970-80005-A each106.95
- 1971-72 Pickup
P7172-80005-A each119.95



DASH WIRING HARNESS

Wires all dash components to engine harness. 1955-56 Pickup

- P55-80010-AS each169.95**
- 1957-59 Pickup
P5759-80010-AS each169.95
- 1960-61 Pickup (Note: this harness is used with a dash instrument cluster harness)
P60-80010-AS each349.95
- 1962 Pickup (Auto trans with factory gauges)
Note: this harness is used with a dash instrument cluster harness
P62-80010-AS each349.95
- 1963 Pickup (auto or manual trans with factory gauges) Note: this harness is used with a dash instrument cluster harness
P63-80010-AS each329.95
- 1933 Pickup (auto or manual trans with warning lights) Note: this harness is used with a dash instrument cluster harness
P63-80010-BS each349.95
- 1964-65 Pickup (auto trans w/factory gauges)
Note: this is used in conjunction with a dash instrument cluster harness
P6465-80010-AS each349.95
- 1964-65 Pickup (manual trans with warning lights) Note: this is used in conjunction with a dash instrument cluster harness
P6465-80010-DS each349.95
- 1966 Pickup (w/factory gauges) Note: this is used in conjunction with a dash instrument cluster harness
P66-80010-AS each349.95
- 1966 Pickup (auto trans with warning lights)
Note: this is used in conjunction with a dash instrument cluster harness
P66-80010-BS each349.95
- 1967-68 Pickup (auto trans with factory gauges)
P67-80010-AS each399.95
- 1967-68 Pickup (auto trans with warning lights)
P67-80010-BS each419.95
- 1967-68 Panel & Suburban (w/gauges)
P67-80010-CS each419.95
- 1967-68 Panel & Suburban (w/warning lights)
P67-80010-DS each419.95
- 1969 Panel & Suburban (w/gauges)
P69-80010-AS each399.95
- 1969 Panel & Suburban (w/warning lights)
P69-80010-BS each419.95
- 1969-72 Pickup (w/factory gauges)
P6972-80010-AS each399.95
- 1969-72 Pickup (w/warning lights)
P6972-80010-BS each419.95

We appreciate your business!

INSTRUMENT CLUSTER HARNESS

- 1960 Pickup (w/ generator light and turn signals)
P60-80015-AS each69.95
- 1961 Pickup (w/ Ammeter gauge and turn signals)
P61-80015-AS each68.95
- 1962-63 Pickup (w/ factory gauges)
P6263-80015-AS each69.95
- 1962-63 Pickup (w/ factory gauges & overspeed light)
P6263-80015-BS each64.95
- 1962-63 Pickup (w/ warning lights)
P6263-80015-CS each69.95
- 1964-66 Pickup (w/ factory gauges)
P6466-80015-AS each69.95
- 1964-66 Pickup (w/ factory gauges & overspeed warning light)
P6466-80015-BS each69.95
- 1964-66 Pickup (w/ warning lights)
P6466-80015-CS each69.95



DOME LIGHT HARNESS

- 1955-59 Pickup
P5559-80020-A each16.95
- 1960-66 Pickup
P6066-80020-AS each16.95
- 1967-72 Pickup
P6772-80020-AS each16.95



CARGO LIGHT WIRING HARNESS

- 1969-72 Pickup
P6972-80021-CS each19.95





ENGINE WIRING HARNESS

From firewall to starter, and distributor. All factory colors and plugs.

1955 Pickup (6 cyl, Auto Trans)	
P55-80025-6AT each	..59.95
1955 Pickup (6 cyl, Manual Trans)	
P55-80025-6MT each	..59.95
1955 Pickup (V8, Auto Trans)	
P55-80025-8AT each	..59.95
1955 Pickup (V8, Manual Trans)	
P55-80025-8MT each	..59.95
1956 Pickup (6 cyl, Auto Trans)	
P56-80025-6AT each	..59.95
1956 Pickup (6 cyl, Manual Trans)	
P56-80025-6MT each	..59.95
1956 Pickup (V8, Auto Trans)	
P56-80025-8AT each	..59.95
1956 Pickup (V8, Manual Trans)	
P56-80025-8MT each	..59.95
1957 Pickup	
P57-80025-6AT each	..59.95
1957 Pickup (6 cyl, Manual Trans)	
P57-80025-6MT each	..59.95
1957 Pickup (V8, Auto Trans)	
P57-80025-8AT each	..59.95
1957 Pickup (V8, Manual Trans)	
P57-80025-8MT each	..59.95
1958-59 Pickup (6 cyl, Auto Trans)	
P5859-80025-6AT each	..59.95
1958-59 Pickup (6 cyl, Manual Trans)	
P5859-80025-6MT each	..59.95
1958-59 Pickup (V8, Auto Trans)	
P5859-80025-8AT each	..59.95
1958-59 Pickup (V8, Manual Trans)	
P5859-80025-8MT each	..59.95
1960-61 Pickup (6 cyl)	
P6061-80025-AS each	..49.95
1960-61 Pickup (8 cyl)	
P6061-80025-BS each	..59.95
1962 Pickup (6 cyl) w/ Factory gauges	
P62-80025-AS each	..59.95
1962 Pickup (6 cyl) w/ warning lights	
P62-80025-BS each	..59.95
1962 Pickup (6 cyl) w/ warning lights	
P62-80025-CS each	..59.95
1962-63 Pickup (8 cyl) w/ factory gauges	
P6263-80025-AS each	..69.95
1962-66 Pickup (8 cyl) w/ factory gauges & factory overspeed warning	
P6266-80025-AS each	..59.95
1963-66 Pickup (6 cyl) w/ factory gauges	
P6366-80025-AS each	..59.95
1963-66 Pickup (6 cyl) w/ warning lights	
P6366-80025-BS each	..59.95
1963-66 Pickup (8 cyl, w/ warning lights)	
P6366-80025-CS each	..59.95

Engine wiring harness cont...



1964-66 Pickup (8 cyl) w/ factory gauges	
P6466-80025-AS each	..59.95
1967 Pickup (6 cyl) w/ auto trans	
P67-80025-AS each	..74.95
1967 Pickup (6 cyl) w/ manual trans	
P67-80025-BS each	..74.95
1967 Pickup (8 cyl, w/ auto trans)	
P67-80025-CS each	..74.95
1967 Pickup (8 cyl, w/ manual trans)	
P67-80025-DS each	..74.95
1968 Pickup (6 cyl & 396 engine) w/ auto trans	
P68-80025-AS each	..82.95
1968 Pickup (396 Manual trans)	
P68-80025-DS each	..82.95
1968-69 Pickup (8 cyl) w/ Auto Trans exc. 396	
P68-80025-ES each	..82.95
1968 Pickup (8 cyl, w/ manual trans, exc 396)	
P68-80025-FS each	..82.95
1968-69 Pickup (6 cyl) with M/T	
P69-80025-BS each	..82.95
1970-72 Pickup (6 cyl, Ayto Trans)	
P7072-80025-AS each	..82.95
1970-72 Pickup (6 cyl, manual trans)	
P7072-80025-BS each	..82.95
1970-72 Pickup (396 auto trans)	
P7072-80025-CS each	..82.95
1970-72 Pickup (396 Manual trans)	
P7072-80025-DS each	..82.95
1970-72 Pickup (8 cyl, auto trans, Exc 396)	
P7072-80025-ES each	..82.95
1970-72 Pickup (8 cyl, Manual trans, exc 396)	
P7072-80025-FS each	..82.95



FRONT LIGHT HARNESS

Fits under hood from firewall to headlights. Does headlights, parklights, side markers, & alternator. 1968-72 Pickup (w/ factory gauges)

F6872-80030-A each	..169.95
1968-72 GMC Pickup (with factory gauges)	
P6872-80030-B each	..169.95



LIGHT/GENERATOR HARNESS

1955 Pickup (6 cyl)	
P55-80030-A each	..69.95
1955 56 Pickup (8 cyl)	
P5556-80030-A each	..69.95
1956 Pickup (6cyl)	
P56-80030-A each	..69.95
1957 Pickup (w/ Heavy duty Generator)	
P57-80030-A each	..69.95
1958 Pickup (w/ heavy duty generator)	
P58-80030-A each	..69.95
1958-59 Pickup	
P5859-80030-A each	..69.95
1960 Pickup (Note: does not include voltage regulator wire)	
P60-80030-A each	..99.95
1961-63 Pickup (w/ out Ammeter)	
P6163-80030-A each	..99.95
1962 Pickup (w/ ammeter)	
P62-80030-A each	..99.95
1963-66 Pickup, Factory Gauges	
P6366-80030-A each	..99.95
1963-66 Pickup, Warning lights	
P6366-80030-B each	..99.95
1967 Pickup, Factory gauges	
P67-80030-A each	..169.95
1967 Pickup (w/ warning lights)	
P67-80030-B each	..169.95
1968 Pickup, Factory gauges	
P68-80030-A each	..169.95
1968 Pickup (warning lights)	
P68-80030-B each	..169.95



LIGHT/ALTERNATOR HARNESS

1969-72 Pickup, Factory gauges	
P6972-80030-A each	..169.95



FUEL TANK WIRE

1955-56 Pickup	
P5556-80035-A each	..9.95
1957-59 Pickup	
P5759-80035-A each	..9.95
1964-66 Pickup	
P6466-80035-A each	..14.95
1967-72 Pickup	
P6772-80035-A each	..14.95



GENERATOR EXTENSION WIRES

(From voltage regulator to generator)

1960-61 Pickup

P6061-80040-A each22.95



1955-57



1958-59

HEADLIGHT CONNECTION WIRE

1955-57 Pickup (Set of 2 for both headlights)

P5557-80045-A set.27.95

1958-59 Pickup (Set of 2 for Both headlights)

P5859-80045-A set.27.95

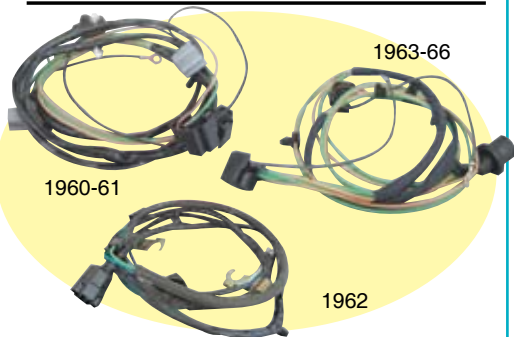

1963-66

1960-61

1962

HEADLIGHT HARNESS

1960-61 Pickup (dual headlights front grill extension)

P6061-80045-A set.39.95

1962 Pickup (Single Headlights in Front grill extension)

P62-80045-A set.36.95

1963-66 Pickup (Single headlights in front grill extension)

P6366-80045-A set.36.95

SERVICE

OUR MOTTO



HEATER WIRING HARNESS

1964-66 Pickup (For deluxe heater)

P6466-80050-A each21.95

1964-66 Pickup (Std. 2 Speed Heater) Includes Blower Power Wire

P6466-80050-B set.21.95

1967-72 Pickup

P6772-80050-A each22.95



HEATER LAMP WIRE

1964-66 Pickup (For Deluxe Heater)

P6466-80051-A each10.95

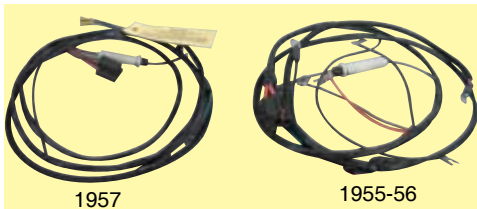

1957

1955-56

OVERDRIVE WIRING HARNESS

1955-56 Pickup (8 cyl)

P5556-80065-A each49.95

1957 Pickup (8 cyl)

P57-80065-A each49.95



TURN SIGNAL HARNESS

1955 Pickup (Dash side)

P55-80070-A each46.95

1955 Pickup (Engine side)

P55-80070-B each14.95

1956 Pickup (Dash side)

P56-80070-A each46.95

1956-57 Pickup (Engine side)

P5657-80070-A each14.95

1957 Pickup (Dash side)

P57-80070-A each46.95



TURN SIGNAL WIRES

Parking and turn signal light wiring harness (for parking and turn signals mounted in the front of the hood)

1962-66 Pickup

P6266-80070-AS set.34.95

1967 Short Stepside

P67-80075-AS each79.95

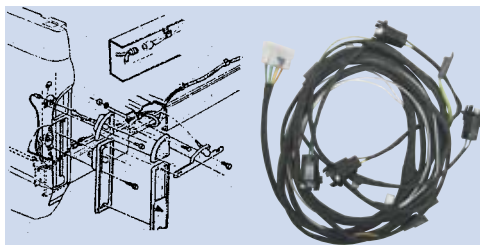

REAR BODY LIGHT HARNESS

1955 Pickup (w/ dual Tail, brake, and Directional Lights)

P55-80075-A each69.95

1955-56 Pickup (w/single tail and brake lights only)

P5556-80075-A each34.95

1956 Pickup (w/dual tail, brake, and directional lights)

P56-80075-A each69.95

1957-59 Pickup (w/dual tail, brake, and directional lights)

P5759-80075-A each72.95

1957-59 Pickup (w/ single tail and brake lights only)

P5759-80075-B each34.95

1960-61 Pickup (firewall to rear frame connector, 131.0")

P6061-80075-A each36.95



BACKUP LIGHT HARNESS

Rear Connector to Backup Light Connection.

1962-66 Fleetside

P6266-80075-AS set.21.95

All-American Deals



TAILIGHT HARNESS

From front thru firewall to rear connector.

1962-66 Pickup (115" WB)

1962-66 Fleetside

P6266-80075-BS set.36.95



REAR TAIL LIGHT BODY WIRING HARNESS

From front thru firewall to rear connector.

1962-66 Pickup (127" X 133" WB)

P6266-80075-CS set.39.95

INTERMEDIATE TAILLAMP WIRING HARNESS

Plugs in at firewall and runs to rear connector. Fits all 127" and 133" wheelbase pickups.

1967-72 Long wheel base (except Panel/Suburban)

P6772-80075-127 set47.95

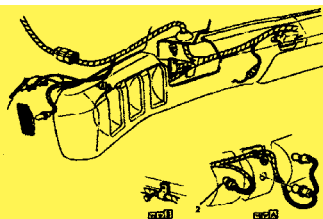

REAR BODY LIGHT HARNESS

Rear light connector to rear lights. Note: set of 2 per vehicle.

1967-68 Panel & Suburban

P6768-80075-A each39.95

1967-68 Fleetside Pickup

P6768-80075-AS set.79.95

1967-68 Pickup (Stepside)

P6768-80075-BS set.79.95

1969-72 Pickup Fleetside and Blazer

P6972-80075-AS set.99.95

1969-72 Pickup (Stepside)

P6972-80075-BS set.99.95

SHORT BED REAR BODY INTERMEDIATE LIGHT HARNESS

Fits from firewall to rear connector.

1967-72 Short bed Fleetside

P6772-80075-115 each.46.95

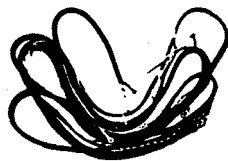

TACHOMETER WIRING HARNESS

1961-62 Pickup

P6162-80080-A each24.95

1963 Pickup

P63-80080-A each24.95

1964 Pickup (6 cyl)

P64-80080-A each24.95

1965-66 Pickup (8 cyl)

P6566-80080-A each24.95

1967 Pickup

P67-80080-A each24.95

1968-72 Pickup

P6872-80080-A each24.95



INTERIOR TRIM STAINLESS STEEL BOLT KIT

Original style, includes all the trim screws. These kits are to include all the exposed screws inside the truck. For example - dash screws, interior moulding screws, kick panel screws, etc. Screws not visible when sitting inside the truck are not included due to different options in different trucks. *Please notice these are very complex kits with numerous screws, washers, etc. Late 1947 - Early 1955 (Original Style)

P4755-80901-O kit5.95

1955 Chevy Pickup (74 pcs)

PU55-80901-501 kit26.95

1956-59 Chevy (80 Pcs)

PU5659-80901-503 kit29.95

1960-66 Pickup (67 Pcs)

PU6066-80901-1125 kit26.95

1967-70 Pickup (43 Pieces)

P6772-80901-O kit15.95

1971-72 Pickup (43 Screws)

P7172-80901-1725 kit.15.95

1971-72 Chevy Cheyenne Super (67 screws)

PU7172-80901-1726 kit24.95

1973-77 Pickup (77 screws)

PU7377-80901-608 kit29.95



EXTERIOR FASTENER KIT

Kits vary from year but the larger kits normally include the following: grill screws, headlight screws, mirror screws, parking light screws, tail light screws, moulding screws, etc.

1960-66 Pickup (28 Pcs)

PU6066-80902-1385 kit10.95

1967-72 Pickup (30 Screws)

PU6772-80902-1390 kit12.95

1973-77 Pickup (32 Pcs)

PU7377-80902-807 kit12.95

1973-77 Pickup (64 Pcs)

PU7377-80902-807A kit24.95

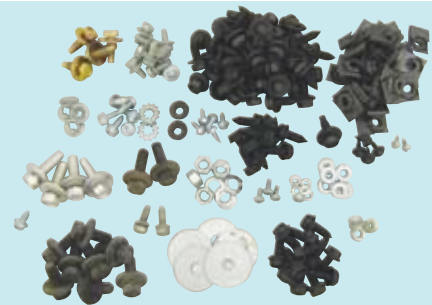

HOOD & TRUNK FASTENER KIT

1957-59 Pickup (112 Pcs)

PU5759-80903-102 kit57.95

1964-66 Pickup (216 Pcs)

PU6466-80903-101 kit112.95

1967-70 Pickup (158 Pcs)

PU6770-80903-100 kit91.95

1973 Pickup (175 Pcs)

PU73-80903-104 kit119.95



DOOR LATCHES BOLT KIT

Stainless steel hex & phillips head bolt kit (does both doors)

Late 1947 - Early 1955

P4755-80906-HP kit6.95

1967-72 Pickup

P6772-80906-HP kit8.95

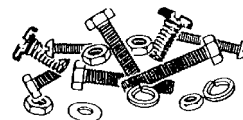

STAINLESS STEEL BOLT KIT

1955-59 Pickup (For door handles, latches, and catches. Stainless steel phillips truss and phillips flat head (original, does both doors)

P5559-80906-RF kit6.95

1960-66 Pickup (For door jambs, sills, and latches. Stainless steel indented hex & phillips flat head bolt kit)

P6066-80906-IF kit6.95

1955-59 Pickup (For firewall, cowl, and battery box stainless steel hex head bolt kit)

P5559-80908-H kit6.95



DOOR JAMB & SILL BOLT KIT

Stainless steel phillips oval & pan head (original style bolt kit)

1967-72 Pickup

P6772-80906-OP kit1.95



COMPLETE BODY BOLT KIT

Stainless steel hex & phillips head. Includes: bumper, door hinges, door latch & catch, door panel, front fender brace rods, front & inner fenders, glove box, grill & gravel pan, headlight & parking lens, hood hinges, latch, catch & braces, interior window trim, outside mirror, ra support, regulator & relay, running boards bolts/screws.

Late 1947-51 Bedless Pickup
P4751-80905-BH kit **124.95**
 1947-51 Late Model, Long Bed Chevy Pickup
P4751-80905-LH kit **246.95**
 1947-51 Short Bed Chevy Pickup
P4751-80905-SH kit **234.95**
 1953-53 Pickup (Bedless)
P5253-80905-BH kit **124.95**
 1952-53 Long Bed Pickup
P5253-80905-LH kit **249.95**
 1952-53 Short Bed Chevy Pickup
P5253-80905-SH kit **229.95**
 1954 Early 1955, Bedless Chevy Pickup
P5455-80905-BH kit **199.95**
 1954 Early 1955 Long Bed Chevy Pickup
P5455-80905-LH kit **239.95**
 1954 Early 1955 Short Bed Chevy Pickup
P5455-80905-SH kit **224.95**
 1955-57 Bedless Chevy Pickup
P5557-80905-BH kit **149.95**
 1955-57 Cameo
P5557-80905-I kit **399.95**
 1955-57 Long Stepside Chevy Pickup
P5557-80905-LH kit **289.95**
 1954 Early 1955 Short Bed Chevy Pickup
P5557-80905-SH kit **279.95**
 1958 Cameo
P58-80905-I kit **339.95**
 1958-59 Bedless Chevy Pickup
P5859-80905-BH kit **159.95**
 1958-59 Fleetside Pickup
P5859-80905-FH kit **289.95**
 1955-59 Pickup
P5859-80905-I kit **299.95**
 1958-59 Chevy Pickup Long Stepside
P5859-80905-LH kit **299.95**

DOOR HINGE BOLT KIT

Stainless steel hex head bolt kit (does both hinges)
 Late 1947 - Early 1955

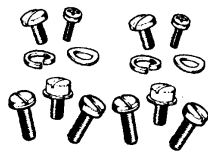

P4755-80907-H kit **7.95**
 1955-59 Pickup
P5559-80907-H kit **9.95**
 1960-66 Pickup
P6066-80907-H kit **19.95**
 1967-72 Pickup
P6772-80907-H kit **29.95**

DOOR HINGES BOLT KIT

Stainless steel, hex head.
 1973-80 Pickup



P7380-80907-KT kit **29.95**



COWL BOLT KIT

Stainless steel indented hex head bolt kit.
 1960-66 Pickup

P6066-80908-I kit **7.95**



COTTER PIN KIT

(140 pcs.)

B-80013-A kit **6.95**

SPEED NUTS

All models
 1/16" stud size



C0AZ-99991-A pkg of 10 **1.95**
 .100 stud size
C0AZ-99991-B pkg of 10 **1.95**
 3/32" stud size
C0AZ-99991-C pkg of 10 **1.95**
 #6-32 screw
C0AZ-99991-D pkg of 10 **1.95**
 1/8" stud size
C0AZ-99991-E pkg of 10 **1.95**
 3/16" stud size
C0AZ-99991-F pkg of 10 **1.95**
 #8-32 screw size
C0AZ-99991-G pkg of 10 **1.95**
 #8 tapping screw size
C0AZ-99991-H pkg of 10 **2.95**
 #8 screw size
C0AZ-99991-I pkg of 10 **2.95**
 5/32" stud size
C0AZ-99991-J pkg of 10 **1.95**
 #10-24 screw size
C0AZ-99991-K pkg of 10 **2.95**
 #10 tapping screw
C0AZ-99991-L pkg of 10 **2.95**
 #12 tapping screw
C0AZ-99991-M pkg of 10 **2.95**
 1/4" x 20 screw size
C0AZ-99991-N pkg of 10 **2.95**
 5/16" x 18 screw size
C0AZ-99991-O pkg of 10 **4.95**
 1/4" stud size
C0AZ-99991-P pkg of 10 **2.95**
 5/16" stud size
C0AZ-99991-Q pkg of 10 **2.95**
 3/8" stud size
C0AZ-99991-R pkg of 10 **2.95**
 7/16" stud size
C0AZ-99991-S pkg of 10 **4.95**

CLUTCH NUT

(12/24) pkg. of 10

B-80022-B kit **4.95**
 (10/32) pkg. of 10

B-80022-C kit **4.95**

(1/4/20) pkg. of 10

B-80022-D kit **4.95**



TUBE NUTS

All models

1/16" stud size

C0AZ-99992-A pkg of 10 **3.95**
 3/32" stud size

C0AZ-99992-B pkg of 10 **2.95**
 1/8" stud size

C0AZ-99992-C pkg of 10 **3.95**

SPIN LOCK BODY BOLTS

All models

(1/4" - 20 x 5/8" long, coarse thread)

C0AZ-99998-A pkg of 5 **2.95**
 (5/16" -18 x 3/4" long, coarse thread)

C0AZ-99998-C pkg of 5 **2.95**
 (5/16" -24 x 1" long, fine thread)

C0AZ-99998-D pkg of 5 **2.95**
 (5/16" -18 x 1" long, coarse thread)

C0AZ-99998-E pkg of 5 **2.95**
 (5/16" -18 x 1 1/8" long, coarse thread)

C0AZ-99998-F pkg of 5 **2.95**
 (5/16"-18 x 1 1/4" long, coarse thread)

C0AZ-99998-H pkg of 5 **2.95**



FENDER WASHERS

All models

1/2" dia. for 3/16" bolt

C0AZ-99997-A pkg of 10 **.95**
 5/8" dia. for 1/4" bolt

C0AZ-99997-B pkg of 10 **.95**
 3/4" dia. for 5/16" bolt

C0AZ-99997-C pkg of 10 **1.95**
 1 1/4" dia. for 1/4" bolt

C0AZ-99997-D pkg of 10 **2.95**
 1 1/2" dia. for 5/16" bolt

C0AZ-99997-E pkg of 10 **2.95**
 1 1/4" dia. for 5/16" bolt

C0AZ-99997-F pkg of 10 **3.95**
 1 1/2" dia. for 3/8" bolt

C0AZ-99997-G pkg of 10 **3.95**
 1 3/4" dia. for 3/8" bolt

C0AZ-99997-H pkg of 10 **4.95**

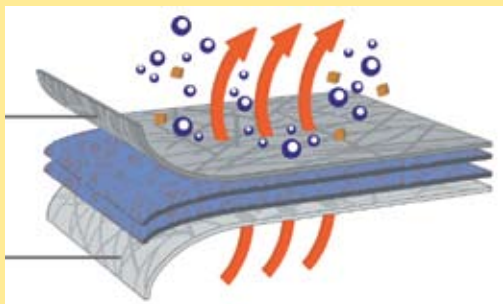

TECHNALON® CUSTOM FIT CAR COVER

The best money can buy!

These covers are made of technalon. It is simply nothing but the best! These are the most rain resistant "breathable" car covers on the market. They are made from a triple fabric. They are a high-tech three layer fabric, lightweight and pliable in all weather conditions. They don't smell, rot or mildew. The outside and inside cover are made of long fibers which make the fabric very tough but soft and non-abrasive. The middle layer is made of shorter fibers that catch water but still allow air to circulate. These covers have double stitched seams and neoprene elastic sewn into the hems at front and rear for a snug, perfect custom fit! They come equipped with non-scratch plastic grommets reinforced into the lower sides, which will accommodate the tie down rope, which is also included with the covers. This is an inexpensive investment for a valuable paint job! Specify blue, gray, or tan.

1934-36 Pickup (Short Bed 1/2 Ton)	1947-50 Pickup (1/2 Ton, No rear bumper)	1958-59 Pickup (Short bed, 1/2 Ton, No rear bumper)
P3436-99999-AS each289.95	P4750-99999-CS each289.95	P5859-99999-CS each289.95
1934-36 Sedan Delivery	1947-50 Pickup (3/4 Ton, No rear bumper)	1958-59 Pickup (Long bed, 3/4 ton, No rear bumper)
P3436-99999-BS each289.95	P4750-99999-DS each299.95	P5859-99999-DS each299.95
1937-38 Pickup (Short Bed 1/2 Ton)	1951-54 Pickup (1/2 Ton w/ rear bumper)	1959 Pickup (Long bed Stepside)
P3738-99999-AS each289.95	P5154-99999-AS each289.95	P59-99999-AS each259.95
1937-38 Sedan Delivery (1/2 Ton)	1951-54 Pickup (3/4 Ton, w/ Rear Bumper)	1960-62 Pickup (Short Bed)
P3738-99999-BS each289.95	P5154-99999-BS each299.95	P6062-99999-AS each289.95
1939-40 Pickup (Short Bed 1/2 Ton)	1951-54 Pickup (1/2 Ton, No Rear Bumper)	1960-62 Pickup (Long bed)
P3940-99999-AS each289.95	P5154-99999-CS each289.95	P6062-99999-BS each299.95
1939-40 Pickup (Long Bed 3/4 Ton)	1951-54 Pickup (3/4 Ton, No rear bumper)	1961-66 Suburban
P3940-99999-BS each299.95	P5154-99999-DS each299.95	P6166-99999-AS each299.95
1940 Sedan Delivery (1/2 Ton)	1955-57 Pickup (Shortbed w/ rear bumper)	1962-66 Pickup (Short bed)
P40-99999-AS each299.95	P5557-99999-AS each289.95	P6266-99999-AS each289.95
1941-42 Pickup (1/2 Ton) Shortbed	1955-57 Pickup (Long Bed w/ rear bumper)	1962-66 Pickup (Long bed)
P4142-99999-AS each289.95	P5557-99999-BS each299.95	P6266-99999-BS each299.95
1941-42 Pickup (3/4 ton Long Bed)	1955-57 Pickup	1967-72 Pickup (Short Bed)
P4142-99999-BS each299.95	P5557-99999-CS each289.95	P6772-99999-AS each289.95
1941-42 Sedan Delivery	1955-57 Pickup (Long bed no rear bumper)	1967-72 Pickup (Long Bed)
P4142-99999-CS each299.95	P5557-99999-DS each299.95	P6772-99999-BS each299.95
1944-46 Pickup Shortbed	1958 Cameo Pickup	1973-87 Pickup (Short Bed)
P4446-99999-AS each289.95	P58-99999-AS each259.95	P7387-99999-AS each289.95
1944-46 Pickup (Long Bed)	1958-59 Pickup (Short bed, 1/2 ton, w/ rear bumper)	1973-87 Pickup (Long bed)
P4446-99999-BS each299.95	P5859-99999-AS each289.95	P7387-99999-BS each299.95
1947-50 Pickup (1/2 Ton w/ rear bumper)	1958-59 Pickup (Long Bed, 3/4 ton, w/ rear bumper)	
P4750-99999-AS each289.95	P5859-99999-BS each299.95	
1947-50 Pickup (3/4 Ton w/ Rear Bumper)		
P4750-99999-BS each299.95		

Pick-up Street Rod Index

Street Rod Miscellaneous 175-178

AutoMeter 179-181

Gauges

Billet Specialities 182-192

Air cleaners, valve covers, engine accessories, breathers, interior and exterior accessories, and steering wheels.

Boese Engineering 193-194

Dash inserts and knobs

Borgeson Mullins 195-202

Universal joints, intermediate shafts, couplers and adapters, vibrations reducers, support bearings, and steering boxes.

Bubba Bilt 203

Door and hood releases. Mity-Tidy® and knobs.

Classic Performance Parts 204-207

Transmission crossmember kits, rear end conversions kits, spring conversion kits, rear lowerin gblock kits, leaf springs, drop kits, sway bars, tie rod and end sets, lowering and handling kits, spindles, power steering conversion kits.

Dakota Digital 208-211

Gauges and bezels, rear view mirrors, gear shift position indicator sending units, gear shift position indicators, digital clocks, power accessory controls, speedometer signal interface and cruise controls and accessories.

Electric-Life 212-215

Power window kits, switches and switch kits, power door lock kits, keyless entry kits, and shaved handle kits.

Flaming River 216-218

Telescopic columns, tilt columns, ignition switches, swing away bracket and swivel mount kits, power racks, remote reservoirs, steering boxes, and much more!

Gennie Shifter 219-221

Shifters, boots and indicators, hand brakes, brake cables, throttle and kickdown cables, and dipsticks.

Ididit 222-230

Steering columns, column add-ons, steering column drops, floor mounts, cable shift linkage kits, and steering wheel adapters.

Master Power Brakes 231-233

Disc brake kits, disc brake bracket sets, master cylinder conversion kits, power brake conversion kits, and dropped spindles.

Moon Eyes 234

Valve covers, breathers, gauges and panels, gas pedal, and moon wheel disc.

Old Air Products 235-238

A/C, heat, and defrost combos

Painless 239-243

Chassis harnesses, universal harnesses, off road harnesses, fuse blocks, relay kits and accessories, switches, and LED lights.

Prothane 244

Body and cab mounts, spring and shackle bushing kits, and sway bar bushings.

Rocky Hinge Inc.. 245-246

Hidden hinge kits, power window kits, Bear Claw kits, and much more!

Spectre 247

Engine kits

Total Cost Involved 248-251

Frames and chassis, crossmembers and mounts, IFS, pick-up components and accessories

Vintage Air. 252-262

Gen II Sure Fit, Gen II Super Cooler, Gen II Super Compac, Gen II Mini Unit, Slim Line Unit, heaters, defrost ducts, and accessory control panels

Walker Radiator Works Inc. 263-264

Radiators

Watson's StreetWorks 265-268

Aluminum trim, lights, hood and decks, LED's, and power window switches and kits.

Wheel Vintiques 269-273

Wheels and hubcaps.

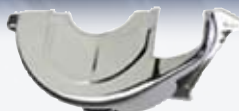

CHROME PLATED STEEL FLYWHEEL COVER

Easy to install.
All with T/350 or T/400
P-0679-350400 each..... 49.95



CHROME PLATED TIMING CHAIN COVER

Chevrolet Small Block 283 - 400
P-0724-283400 each.....17.95
Chevrolet Big Block 396 - 454
P-0724-396454A each.....16.95



RADIATOR OVERFLOW TUBE

Stainless steel "Street Rod type" complete with mounting hardware, 13 inches long.
1932-80 All
B-1219-OF 1.....59.95



CHROME PLATED OIL PAN

1955-79 Small block 283-400 w/drivers side dipstick.
Steel. Stock 4 quart capacity.
P-1426-283400 each.....64.95



STEALTH TAILGATE LATCHES

These cool tailgate latches install into the top of the tailgate so you can eliminate those unsightly tailgate chains. These latches rely on spring loaded pins to securely lock your tailgate in position. Plain
CPSLK-P kit..... 49.00
Stainless steel
CPSLK-S kit..... 59.00



Chevrolet Big Block Chevrolet Small Block GM Turbo 350

CHROME PLATED DIP STICK & TUBE

Chevrolet Big Block engines
P-1516-BBA each.....12.95
GM Turbo 350 engines
P-1516-TGM350 each.....15.95
GM Turbo 400 Transmissions
P-1516-TGM400 each.....15.95



TAIL LAMP ASSEMBLY

All
Correct black body, stainless rim, glass lens, the "teardrop" tail lamp.
B-2679-TD each.....19.95
All
With blue dot installed, correct black body, stainless rim, glass lens, the "teardrop" tail lamp.
B-2679-TDBD each.....24.95

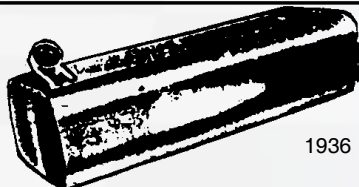

STAINLESS STEEL GAS TANKS

Aftermarket streetrod gas tanks, not original style.
1936 Pickup (19 gall)
Stainless steel.
P36-3001-SSSPO each.....599.95
1941-46 Pickup (Stock Capacity)
Stainless steel.
P4146-3001-SSSPO each.....629.95
1947-48 Pickup
1947-53 Suburban & Panel Delivery (Stock Capacity)
Stainless steel.
P4753-3001-SSSPO each.....629.95



ALUMINUM GAS TANKS

19 gallon tank fits between the frame rails and are fully baffled. Fuel is filled through the bed floor. The best aluminum tank on the market!
1947-54 Truck
P4754-3001-ABF each.....469.95
1955-59 Truck
P5559-3001-ABF each.....419.95
1963-72 Truck
P6372-3001-A each.....419.95

Fits Wheel Vintique only



RALLEY WHEEL CENTER CAP

1971-99 All with series 33 and 37 wheels
Stainless steel '67 style ralley center cap. "Chevrolet motor division". Non disc brakes.
F67-5858-SETB set of 4.....139.95
1971-99 Series 33 and 37 wheels
Original style ralley wheel center cap with bowtie. Chrome plated steel.
B6876-5858-SET set of 4.....269.95
1971-99 Series 33 and 37 wheels
Original style with bowtie. Chrome plated steel.
B6876-5871-SET set of 4.....329.95



HIDDEN BUMPER RECEIVER HITCH ASSEMBLY

Female end is behind tag. Complete with mounting hardware, does not include male receiver.
1967-72 Chevy/GMC
P6772-7800-H each.....199.95

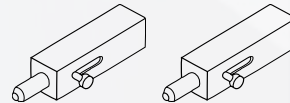

HIDDEN TAILGATE LATCH

Fits all years and types of trucks, stainless steel moving parts, replaces stock chains and hooks.
B-17225-HTL pair.....79.95

MICSELLANEOUS STREET ROD



FULLY AUTOMATIC AM/FM RADIO POWER ANTENNA, UNIVERSAL

5 section stainless steel mast extends to 33", 12 volt, comes with 5 angled bases for proper fit.

1932-80 All

P-9645-PA each47.95



UNIVERSAL SIDE MOUNT ANTENNA

Real nostalgia! Mounts on side of cowl- neat early day accessory. New style with nostalgic red ball, new & improved quality. Has a bullet cap on the bottom of the mast.

Universal - fits all

P-9645-SMA each.39.95



HIDEAWAY 100W AM/FM RADIO

Custom auto sound secret audio hideaway 100 watt am/fm CD changer controller featuring IR remote. Has line of sight range. Ideal for any vehicle, simply leave your factory radio intact. LCD display-sensor unit can be mounted almost anywhere & can be controlled via wireless remote. The tuner/amplifier unit can be hidden out of sight - under dash, seat, etc.. Features: am/fm stereo - 100 watts, 4 x 25w - CD changer control.

6 disc changer sold separately. Separate bass/treble control. S-4 way fader. 2 sets RCA preamp outputs - 18 fm/12 am presets. Dimensions: LCD- 4.5" x 1.5" x .75" tuner- 7" x 1.6" x 5.5"

P-9650-SAIR each239.95

Featuring RF remote. Has range up to 40' away. LCD display sensor unit can be mounted almost anywhere & can be controlled via wireless remote from up to 40' away.

P-9650-SARF each.259.95



JVC RADIO

88 watts, auto reverse, separate bass and treble, 4 way fader, 20 presets, pre-set scan, clock, power antenna lead, green illumination. 1964-66 Chevy/GMC

w/ chrome face

P6466-9650-CJVC each.249.95

1964-66 Chevy/GMC

w/o chrome face

P6466-9650-JVC each239.95

1967-72 Chevy/GMC

w/o chrome face

P6772-9650-JVC each239.95

1972-80 Chevy/GMC

w/ chrome face

P7380-9650-CJVC each.249.95

1972-80 Chevy/GMC

w/o chrome face

P7380-9650-JVC each239.95

1947-53 Chevy **Cassette**

w/ chrome face

P4753-9650-CVC each.249.95

1947 53 Chevy Pickup **cassette**

without chrome face

P4753-9650-JVC each239.95

1955-59 Chevy Pickup **radio only - no cassette**

with chrome face

P5559-9650-CJVC each.249.95

1955-59 Chevy Pickup **no cassette**

without chrome face

P5559-9650-JVC each199.95



REMOTE 10 DISC CD CHANGER

10 disc CD changer. For use with custom auto sound secret audio, USA-5, and USA-6.

B-9650-10 each299.95

6 disc CD changer

P-9650-6CD each279.95



BRACKETED DASH MOUNT FRONT SPEAKERS

30 watts

1967-72 Pickup (without air)

A6667-9650-DFS each44.95

1967-72 Chevy/GMC (stereo)

P6772-9650-SDS each44.95

1973-86 Chevy/GMC (stereo)

A7072-9650-DFSFS each.39.95



CHEVY TRUCK USA-1 RADIO

- Chrome Face/Nose • AM/FM Stereo Cassette
- PLL Electronic Synthesized Tuner
- 24 Presets (6 AM/ 18 FM) • Seek • Scan
- Best Stations Memory • Preset Memory Scan
- Lo/Dx Button • Manual Electronic Tuning
- Separate Bass/Treble Controls
- Balance • 4-Way Fader • Auto Reverse
- Tape Eject • Tape/Stereo Indicators
- Power Output: 12W x 4 • RCA Preamp outputs
- Digital Clock • Power Antenna Lead

1947-53 Pickup

P4753-9650-AS each229.95

1947-53 GMC Pickup

P4753-9650-ASG each.229.95

1955-59 Pickup

P5559-9650-AS each229.95

1964-66 Chevy Pickup (w/ out AC)

P6466-9650-AS each229.95

1964-66 GMC Pickup

P6466-9650-DSG each.229.95

1964-66 Chevy Pickup (w/ AC)

P6466-9650-DS each229.95

1967-72 Chevy Pickup (w/ AC)

P6772-9650-DS each229.95

1967-72 Chevy Pickup (w/ out AC)

P6772-9650-AS each229.95

1967-72 GMC Pickup

P6786-9650-DSG each.229.95

1973-86 Chevy Pickup

P7386-9650-DS each229.95



CHEVY TRUCK USA-03 RADIO

- Chrome Face/Nose • AM/FM Stereo Cassette
- Mono/Stereo Button • Lo/Dx Button
- Manual Tuning • Separate Bass/Treble Controls
- Balance • 4-Way Fader • Auto Reverse
- Fast Forward/Rewind • Tape Eject
- Tape/Stereo Indicators • Power Output: 6W x 4

• Power Antenna Lead

1964-66 Chevy Pickup (w/ out AC)

P6466-9650-BS each199.95

1967-72 Chevy Pickup (w/ out AC)

P6772-9650-BS each199.95

1973-86 Chevy Pickup

P7386-9650-BS each199.95



CHEVY TRUCK USA-04 RADIO

- Chrome Face/Nose • AM/FM Stereo Cassette
- PLL Electronic Synthesized Tuner
- 24 Presets (6 AM/ 18 FM) • Seek • Scan
- Best Stations Memory • Preset Memory Scan
- Lo/Dx Button • Manual Electronic Tuning
- Seperate Bass/Treble Controls
- Balance • 4-Way Fader • Auto Reverse
- Tape Eject
- Dynamic Noise Reduction • Music Search
- Metal Tape Compatible • Fast Forward/Re-wind
- Power Output: 10W x 4 • Power Antenna Lead
- Digital Clock • 1/8" CD/Aux. Input Jack

- 1947-53 Chevy Pickup
P4753-9650-CS each299.95
 1947-53 GMC Pickup
P4753-9650-CSG each299.95
 1955-59 Chevy Pickup
P5559-9650-CS each299.95
 1964-66 Chevy Pickup (w/ out AC)
P6466-9650-CS each299.95
 1964-66 GMC Pickup
P6466-9650-CSG each299.95
 1967-72 Chevy Pickup (w/ out AC)
P6772-9650-CS each299.95
 1967-72 GMC Pickup
P6786-9650-CSG each299.95
 1973-86 Chevy Pickup
P7386-9650-CS each299.95



KICK PANELS WITH PROVISIONS TO INSTALL YOUR OWN SPEAKERS

ABS plastic. Black.
 1967-72 Chevy/GMC Pickup, Blazer, and Suburban.

- P6772-14630-B Pair89.95**



DUMMY SPOTLIGHT FOR THE 1950'S & 60'S MODELS

Reproduction of the original chrome accessory dummy spotlight.

- 1950's & 60's models Pickup
B-15200-DMY each39.95



P6066-14630-TAR

P6066-14630-PIO

KICK PANELS W/SPEAKERS

- Interior abs kick panel. Black.
 1955-59 Chevy/GMC Pickup
 With built in 4 inch Pioneer 70 watt coaxial speakers.
P5559-14630-PIO pair199.95
 1955-59 Chevy/GMC Pickup
 With built in 4 inch coaxial 60 watt speakers.
P5559-14630-TAR pair149.95
 1960-66 Chevy/GMC Pickup
 With 6 1/2 inch coaxial 120 watt Pioneer speakers.
P6066-14630-PIO pair199.95
 1960-66 Chevy/GMC Pickup
 With built in 6 1/2 inch triaxial 80 watt speakers.
P6066-14630-TAR pair149.95
 1967-72 Pickup
 With built in Pioneer co-axial 120 watt speakers.
P6772-14630-PIO pair199.95
 1967-72 Pickup
 With built in Pioneer tri-axial 80 watt speakers.
P6772-14630-TAR pair149.95



ONE PIECE SIDE GLASS CONVERSION KIT

Eliminate your trucks vent windows! Kit includes all felt channels, custom scraper set, filler panels, brackets, and hardware to complete 2 doors. Requires one hole to be drilled in the door jam area at the front of the door and one small bracket to be cut. Best to use with original complete doors, as there are usually fitting problems with reproduction doors.

- 1955-59 Chevy/GMC Pickup (clear glass)
P5559-16180-1PC kit389.95
 1955-59 Chevy/GMC Pickup (medium tint glass)
P5559-16180-1PCT kit389.95
 1967-72 Chevy/GMC Pickup (clear glass)
P6772-16180-1PC kit399.95
 1967-72 Chevy/GMC Pickup (medium tint glass)
P6772-16180-1PCT kit399.95



POWER WINDOW SWITCH KIT

Works with the power window regulator kit. Includes switches, wiring harness and directions.

- 1967-74 Chevy Full Size Pickup
P6774-16260-SW kit149.95

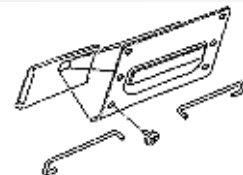

TAILGATE HANDLE RELOCATOR KIT

- 1967-72 Chevy (Fleetside)
P6772-17615-HK kit114.95



TAILGATE HANDLE RELOCATOR

- 1973-80 Fleetside
P7380-17615-HK each114.95



CHROME PLATED DROP DOOR EDGE MIRROR

Fits both sides.
 3" head

- B-16068-AL each19.95**
 4" head for better vision
B-16068-BL each19.95



UNIVERSAL DOOR MOUNT MIRROR

AAA quality, chrome plated. Includes mounting hardware. Fits right or left side.
 1932-72

- B-16038-UDM each79.95**
 All
B-16068-UDM each79.95

SPINDLES & DROP KITS



Early Classic offers the original 1960-72 Drop and Stock Height Spindles, machined to accept your truck's original tie rods and ball joints. While others offer later model parts that require changing your suspension components in order for them to fit, ever EC Spindle is designed for your specific year and model of truck.

Dropped Spindles acheive their lowered stance by relocating the spindle pin higher in the casting, which in turn, lower the vehicle by an equal amount. The stock spring and shock absorber travel remain untouched, leaving the factor suspension geometry intact.

Gone are the harsh ride and alignment problems common with other forms of lowering. EC Drop Spindles are engineered to lower your truck 2.5", allowing the maximum amount of front wheel backspacing on the market !

Part #	Application	Description	Price
01-6062	1960-62 C10	2.5" Drop Spindles (requires disc brakes)	299.00
01-6062S	1960-62 C10	Stock Spindles (requires disc brakes)	299.00
01-6370	1963-70 C10	2.5" Drop Spindles (requires disc brakes)	299.00
01-6370S	1971-72 C10	Stock Spindles requires disc brakes).....	249.00
01-7172	1971-72 C10	2.5" Drop Spindles (requires disc brakes)	249.00
01-7387HD	1973-87 C10	2.5" Drop Spindles (w/1.25" thick rotors) requires disc brakes).....	249.00
01-7387LD	1973-87 C10	2.5" Drop Spindles (w/1" thick rotors)	239.00



COMPLETE DROP KITS

These are complete kits with everything needed to lower your truck. We will list indivudal pieces with each kit.

1963-72 C10 2/4 DROP KIT

- 2" Drop Front Coils
- 4" Drop Rear Coils
- 4 KYB Shocks
- 24DK kit..... 399.00

1963-72 C10 4/6 DROP KIT

- 2.5" Drop Front Coils
- 1.5" Drop Front Springs
- 6" Drop Rear Coils
- 4 KYB Shocks
- Shock Mount Relocator Kit
- Super Track Bar Kit
- 46DK kit..... 849.00



1963-72 C10 PREMIUM 2/4 DROP KIT

- 2" Drop Front Coils
- 4" Drop Rear Coils
- 4 KYB SHocks
- Shock Mount Relocator Kit
- Adjustable Panhard Bar
- 24PDK kit..... 559.00

1953-72 C10 4/6 DROP KIT WITH DISC BRAKE CONVERSION KIT

- 2.5" Drop Front Coils
- 1.5" Drop Front Springs
- 6" Drop Rear Coils
- 4 KYB SHocks
- Shock Mount Relocator Kit
- Call for details
- 46DDBK5 (5 lug) kit..... 1449.00
- 46DDBK6 (6 lug) kit..... 1449.00

DROP DEFINITIONS:

2/4 = Drop 2" in front & 4" in rear
4/6 = Drop 4" in front & 6" in rear

PACKAGE SOLUTIONS



The Auto Meter Collection of Street Rod gauges was introduced to accent the class and artistic beauty found within a street rod interior. A large variety of dial faces and bezel combinations are accented by a high class numbering style, to give your street rod the look of true American performance. Your car is an original, shouldn't your gauges be too ?



Convenient 5 Instrument Kit

Includes everything you need to get your show on the road.

Programmable

Electric speedometer includes LCD odometer with trip function, and revolutionary "push button" calibration for easy tire size and gear ratio changes.

Upgrade your Street Rod Kit with a quality matching Tachometer and Clock. The clock is an extremely attractive accessory that will compliment any custom interior. Round off the complete set with either a 2-1/16" tachometer, or a 3-1/8" tachometer. Each instrument gives the high performance look desired by the industry's top builders.



These kits make it easy to pretty up your ride. Choose from the following collections from Autometer®.

- American Platinum
- Antique Beige
- Golden Oldies
- Arctic White
- Designer Black
- Old Tyme White
- Old Tyme Black

We have other gauges available. Call for more details !

Range:

120 MPH speedo, 100 PSI oil pressure, 100°-250° F water temp, 8-18V voltmeter, & 240ΩE/33ΩF fuel level. Includes mounting hardware, lighting & all gauge senders. Speedometer sender may be needed.

Arctic White



Mechanical SPEEDOMETER KIT

1300 kit 350.34



5" quad gauge/SPEEDOMETER KIT

1303 kit 598.67



ELECTRIC SPEEDOMETER KIT

1302 kit 399.41



Electric SPEEDOMETER KIT

Black nickel bezel.

1402 kit 418.90

Designer Black™



5" quad gauge/SPEEDOMETER KIT

Polished chrome bezels.

1403 kit 598.67



Mechanical SPEEDOMETER KIT

Black nickel bezel.

1400 kit 365.20



Range:

120 MPH speed, 100 PSI oil pressure, 100°-250° F water temp, 8-18V voltmeter, & 240ΩE/33ΩF fuel level. Includes mounting hardware, lighting & all gauge senders. Speedometer sender may be needed.

American PLATINUM

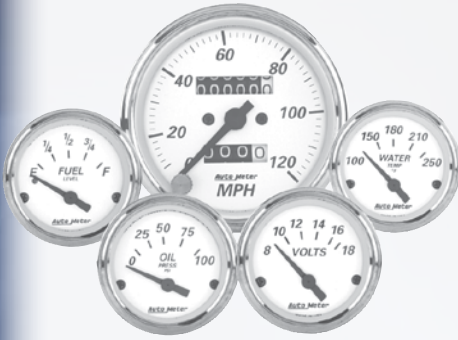

Mechanical SPEEDOMETER KIT
1901 kit 365.20

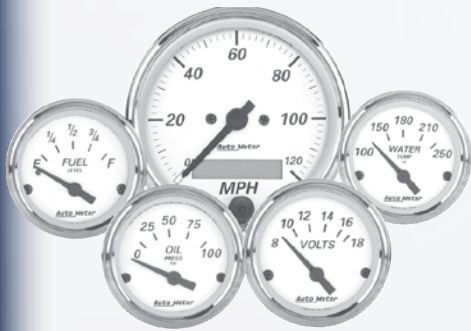

ELECTRIC SPEEDOMETER KIT
1902 kit 418.90

ANTIQUE BEIGE™



Mechanical SPEEDOMETER KIT
1501 kit 365.20



ELECTRIC SPEEDOMETER KIT
1502 kit 418.90

GOLDEN OLDIES™



Mechanical SPEEDOMETER KIT
1808 kit 350.34



ELECTRIC SPEEDOMETER KIT
1809 kit 399.41

Old Tyme White™



Electric SPEEDOMETER KIT
1602 kit 399.41



5" quad gauge/SPEEDOMETER KIT
1603 kit 598.67



Mechanical SPEEDOMETER KIT
1601 kit 350.34

Range:
120 MPH speedo, 100 PSI oil pressure,
100°-250° F water temp, 8-18V voltmeter, & 240ΩE/33ΩF fuel level. Includes mounting hardware, lighting
& all gauge senders. Speedometer sender may be needed.



Electric SPEEDOMETER KIT
1709 kit 399.41

Old Tyme Black™



Mechanical SPEEDOMETER KIT
1708 kit 350.34

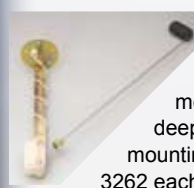

UNIVERSAL FUEL LEVEL SENDER
For 240ΩE/33ΩF gauge models. Adjustable for 5" - 24" deep tank. Fits standard 5-Bolt mounting flange.
3262 each 35.64

REPLACEMENT SENDERS

(Pressure)
80 PSI Electric Oil Pressure Gauges
2241 each 35.60
100 PSI Electric Oil Pressure Gauges
2242 each 35.60



PROGRAMMABLE ELECTRIC SPEEDOMETER SENDERS – For use with all Auto Meter electronic speedometers



Hall Effect Speedometer Sender
7/8" - 18THD, Hall effect sender, 16 pulse per rev. Includes pass-thru drive for cruise control.
5291 each 80.93

Hall Effect Speedometer Sender
Ford® Plug-in, Hall Effect Sender, 16 pulse per rev. Includes pass-thru drive for cruise control.
5292 each 93.72

RIGHT ANGLE FITTINGS

For use with Auto Meter Mechanical Pressure and Vacuum Gauges with 1/8" NPT port.
For pressure gauges
Using #3, braided stainless steel line.
3270 each 6.16
Using #4 braided stainless steel line.
3271 each 6.16
Using 1/8" copper or nylon tubing.
3272 each 6.16
Blue Aluminum Anodized
Version of above 3271
3278 each 8.20



REPLACEMENT SENDERS

Full Sweep Electric
Replacement Temperature Sender
2252 each 25.33
Autogage
For electric temperature gauges
2385 each 11.52



REPLACEMENT SENDERS

Pressure
Replacement sender for 100 PSI oil & fuel (Full Sweep)
2246 each 131.68



TEMPERATURE ADAPTERS

Weld in adapter for 1/8" NPT (Pyrometer probe, electric trans, and oil temp)
2260 each 8.99
Weld in adapter - steel adapter for all mechanical oil and transmission temperature gauges. (shown)
2261 each 10.74



TEMPERATURE ADAPTERS

Auto Meter
3/8" Brass NPT Temp Adapter
2263 each 7.11
1/2" Brass NPT Temp Adapter
2264 each 7.11
3/8" Red Aluminum
2272 each 9.15
NPT Temp Adapters
1/2" Red Aluminum NPT Temp Adapt
2273 each 9.15
Autogage
3/8" Brass NPT Temp Adapter
2370 each 8.67
1/2" Brass NPT Temp Adapter
2372 each 8.67





Valve Covers

Our polished aluminum valve covers are made to draw attention to your engine compartment. Choose from one of the many styles for small block Chevy™ applications. All designs are available in both short and tall heights and accept a 1-1/4" breather. Center bolt styles are available in short only.

Use tall styles if using roller rockers or stud girdles. Metal baffles are included with all valve covers. Don't forget to check out the matching air cleaners and breathers to complete your engine design.

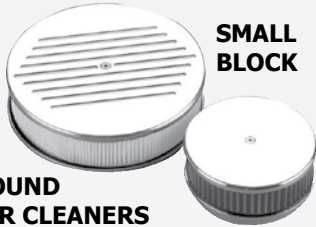

SMALL BLOCK

ROUND AIR CLEANERS

Our round air cleaners are available in 6-3/8" and 10" diameters. Lifetime K&N air filter included with 6-3/8" air cleaner. The 10" diameter air cleaner has a common replaceable element available at any auto parts store. Both are 3" in height.

- 6-3/8" Ball Milled
15120 **69.95**
- 6-3/8" Plain
15129 **69.95**
- 10" Ball Milled
15220 **99.95**
- 10" Plain
15229 **99.95**



DUAL QUAD BALL MILLED



DUAL QUAD PLAIN



DUAL QUAD HEARTBEAT

These are available in Ball Milled, Plain, and Heartbeat designs. These dual quad air cleaners feature an adjustable base to easily fit carb spacings of 6-7/16" to 8-7/8". K&N lifetime air filter included. Some applications may require trimming of mounting plates. Size: 17-1/2" L x 9-3/8" W x 3 1/4" H

- Ball Milled Polished
15520 **224.95**
- Heartbeat Polished
15525 **224.95**
- Plain Polished
15529 **224.95**

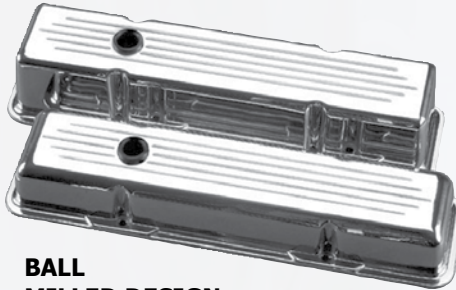

BALL MILLED DESIGN

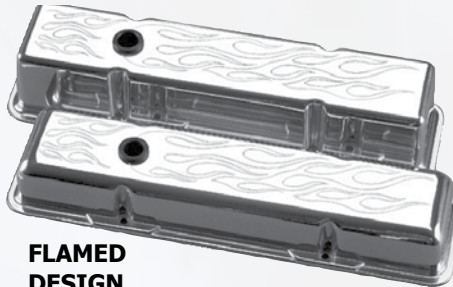

FLAMED DESIGN

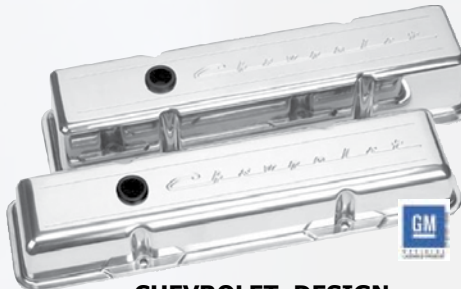

CHEVROLET DESIGN

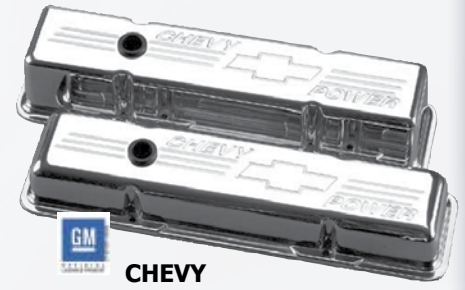

CHEVY POWER DESIGN

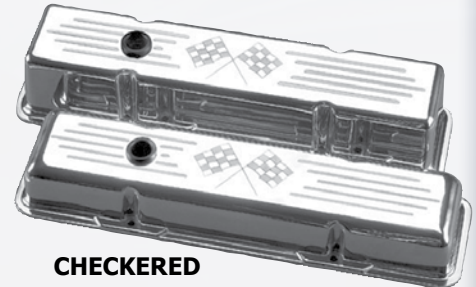

CHECKERED FLAG DESIGN

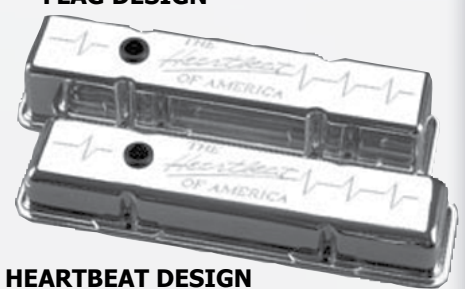

HEARTBEAT DESIGN

Small Block Valve Covers - SHORT

* Includes Metal Baffles - 2-3/4"

- Ball Milled Design
95120 pair **99.95**
- Chevy Power Design
95122 pair **119.95**
- Chevrolet Design
95123 pair **119.95**
- Heartbeat Design
95126 pair **119.95**
- Checked Flag Design
95127 pair **119.95**
- Flame Design
95128 pair **109.95**
- Plain
95129 pair **79.95**

Small Block Valve Covers - TALL

* Includes Metal Baffles - 3-3/4"

- Ball Milled Design
95220 pair **99.95**
- Chevy Power Design
95222 pair **119.95**
- Chevrolet Design
95223 pair **119.95**
- Heartbeat Design
95226 pair **119.95**
- Checked Flag Design
95227 pair **119.95**
- Flame Design
95228 pair **109.95**
- Plain
95229 pair **79.95**

Small block Chevy valve covers



BALL MILLED

Center Bolt Style

SMALL BLOCK VALVE COVERS CENTER BOLT 2-HOLE STYLE

*Includes Bolts

2 Hole Ball Milled Style

95820 pair 149.95

2 Hole Checkered Flag Style

95827 pair..... 149.95

2 Hole Plain

95829 pair129.95

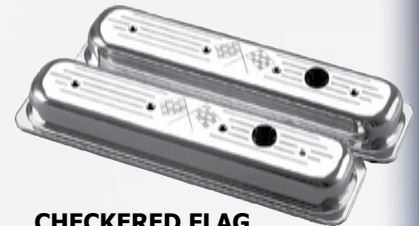
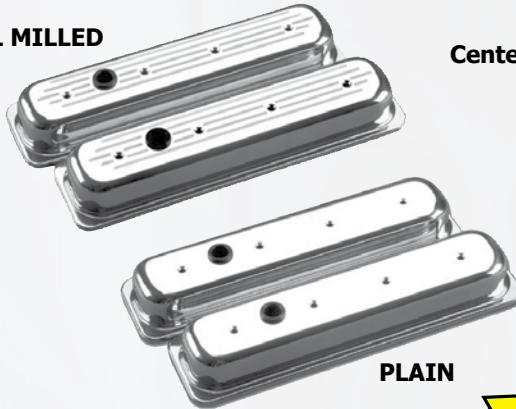

CHECKERED FLAG

PLAIN



SMALL BLOCK CHEVY VALVE COVERS, CENTER BOLT

3 Hole Ball Milled

95920 pair169.95

Big block chevy valve covers

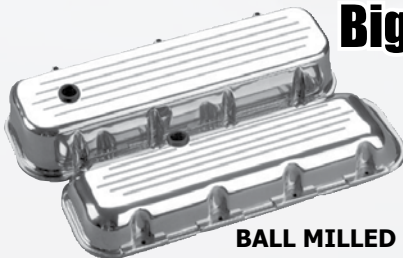

BALL MILLED

BIG Block Valve Covers - TALL

3-3/4" Tall (Bolts Included)

Ball Milled Design

96120 pair 179.95

Chevy Power Design

96122 pair 179.95

Heartbeat Design

96126 pair 179.95

Checkered Flag Design

96127 pair 179.95

Plain

96129 pair159.95

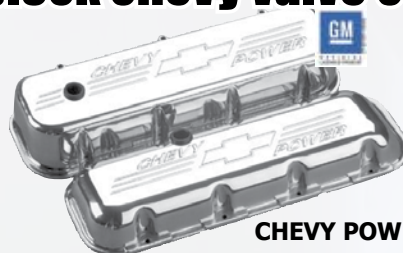

CHEVY POWER



HEARTBEAT



CHECKERED FLAG

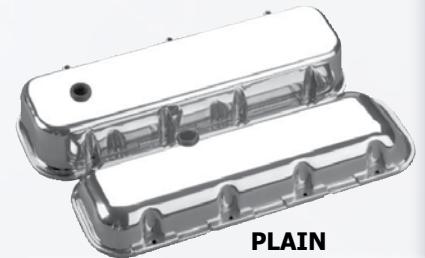

PLAIN

BIG Block Valve Covers - SHORT

2-3/4" Tall (Bolts included)

Ball Milled Design

96020 pair 179.95

Chevy Power Design

96022 pair 179.95

Heartbeat Design

96026 pair 179.95

Checkered Flag Design

96027 pair 179.95

Plain

96029 pair159.95

POWER STEERING BRACKET & PULLEY

For use with Chevy™ Small block motors with GM remote Type II power steering pumps. Designed to work with Billet Specialties pulleys and brackets - available for both long and short style water pumps. Both the bracket and pulley are machined from billet aluminum and given a high polished finish. Bracket mounts low on driver side of engine block. NOTE: Fittings, Hoses and Pump NOT included.

12120 (short water pump) 149.95

12220 (long water pump)149.95

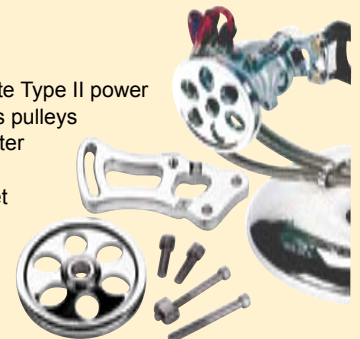



A/C COMPRESSOR COVER

The cover is machined from billet aluminum designed to fit the Sanden 508 aftermarket compressor unit.

8712039.95



POWER STEERING REMOTE RESERVOIRS

Our power steering remote reservoirs are machined from billet aluminum and given a high polished finish. The remote reservoir features a vented cap and internal baffling for foam free operation. Designed for -6 & -10 AN fittings (works with most aftermarket hose kits). The included mounting bracket features an internal key-lock design that hides all mounting hardware for a smooth finish. *Fittings and hoses not included.

77920 (Ribbed Style) 134.95

77910 (Smooth Style)134.95



ALTERNATOR PULLEYS

Choose from either the replacement billet alternator pulley or the unique alternator fan, pulley, and nose cone set-up. The alternator pulley and fan are machined from one piece of billet aluminum to provide superior balance and strength. The bolt-on nose cone hides the alternator fan nut and washer. Both styles fit most GM, Delco and Ford® alternators.

85120 Alternator pulley 24.95

85220 Alternator set-up49.95



Press on 2 groove

Press on 1 groove

POWER STEERING PULLEY

Machined from 6061-T6 billet aluminum and polished to a mirror finish these power steering pulleys are designed to work with GM power steering pumps. Available in either 1/8" keyway or press-on shaft styles. Keyway pulley works with both long or short water pump applications. Press-on pulleys are for long water pumps only.

86120 (1/8" Keyway) 59.95

86420 1 Groove press-on 59.95

86520 2 Groove press-on64.95

Billet Serpentine Alternator Pulley and Nose Cone

The design features pulley & fan machined from one solid piece of billet aluminum for maximum strength and balance with a bolt-on nose cone to hide the alternator fan nut and washer. Designed to fit 6-groove serpentine belt systems with GM Large or Small case alternators.

878830 59.95



The Billet Specialties Difference

Pulley Set 78025

Use Billet Specialties Pulley Set 78025 when running Billet Specialties Long Water Pump Alternator Brackets (11220 or 11420) without A/C.

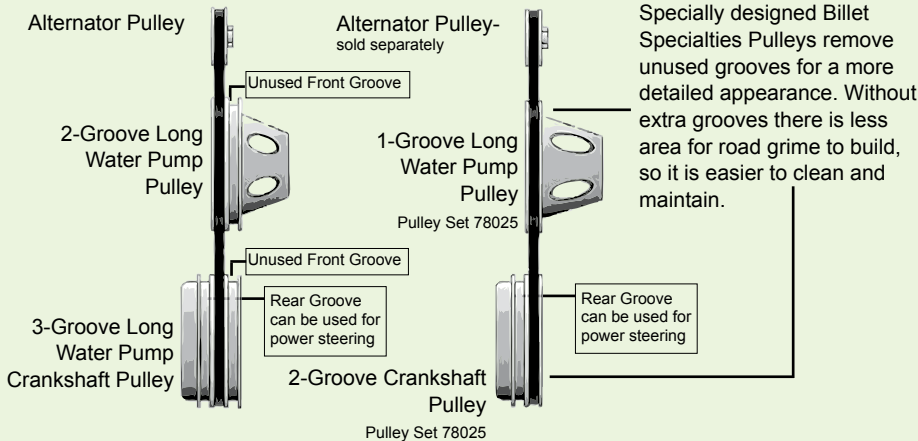

Conventional Pulley VS. Billet Specialties Pulley Set 78025

PCV VALVE

The PCV valve is designed to be used with Billet Specialties and O.E. valve covers. When using O.E. valve covers, factory grommet must be used. The grommet is included for Billet Specialties applications. Uses common replaceable PCV valve inside.

22120 Polished24.95



VALVE COVER HOLD DOWNS

Valve cover hold downs work with both big block and small block engines. Each hold down is 2-7/8" tall with 1/4-20 threaded stud. Sold in packs of 4 only.

95011 Acorn 19.95

95012 Ribbed 19.95

95013 Hex19.95

BILLET LINE CLAMPS

The 2 pc billet aluminum line clamps are packaged in quantities of four and come with stainless hardware.

65110 (3/16" clamp) 7.95

65210 (1/4" clamp) 7.95

65310 (5/16" clamp) 7.95

65410 (3/8" clamp)7.95



Engine Accessories

WATER PUMP PULLEYS & NOSE CONES

Machined from 6061-T6 billet aluminum for incredible balance and strength. Available for small and big block Chevy™ motors with long or short style water pumps. Fully polished finish.



STREET ROD



Short Style



Long Style



Part #	Engine	Groove	Water Pump	Price
78110	SB/BB	1 Groove	Long	69.95
78120	SB/BB	2 Groove	Long	69.95
80120	Small Block	1 Groove	Short	74.95
80220	Small Block	2 Groove	Short	74.95
82120	Big Block	1 Groove	Short	74.95
82220	Big Block	2 Groove	Short	74.95
84120	Nose Cone	1 Groove	Short	15.95
84220	Nose Cone	2 Groove	Long	15.95

CRANKSHAFT PULLEYS

Long or Short Water Pump - Crankshaft pulleys are machined from billet aluminum and fully polished. Available for small and big block Chevy™ applications with either a long or short water pump.

3 Groove



2 Groove



Single Groove

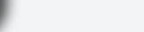

2 Groove



3 Groove



Single Groove



The benefit of a billet aluminum pulley over a cast pulley is equal density. With a cast pulley the aluminum is poured into a mold and then allowed to cool. This process can create variations in density throughout the pulley. Dense areas are heavier than the more porous areas causing the pulley to vibrate at high RPMs. A billet pulley is equally dense throughout; equal weight translates to a more true and balanced pulley drive system.

Part #	Engine	Groove	Water Pump	Price
81120	Small Block	1 Groove	Short	59.95
81220	Small Block	2 Groove	Short	64.95
81320	Small Block	3 Groove	Short	69.95
83120	Big Block	1 Groove	Short	59.95
83220	Big Block	2 Groove	Short	64.95
83320	Big Block	3 Groove	Short	69.95
78210	Small Block	1 Groove	Long	64.95
78220	Small Block	2 Groove	Long	64.95
78230	Small Block	3 Groove	Long	69.95
79210	Big Block	1 Groove	Long	64.95
79220	Big Block	2 Groove	Long	64.95
79230	Big Block	3 Groove	Long	69.95

BREATHERS

Designed for performance, ease of maintenance and longevity in mind. The 2 pc. design with a positive O-ring seal provides easy access to the washable breather filter. The PCV breathers features a common replaceable built in PCV valve.



BOWTIE



CHECKERED FLAG



FLAMED



PLAIN



OVAL BALL MILLED



HEARTBEAT

BILLET BREATHERS

20120 Plain 1-1/4" VC Hole	29.95
20125 Plain 1" VC Hole	29.95
20220 Bowtie 1-1/4" VC Hole	34.95
20320 Flamed 1-1/4" VC Hole	34.95
20520 Heartbeat 1-1/4" VC Hole	34.95
20720 Checkered Flag 1-1/4" VC Hole	34.95
20820 Round Ball Milled - 1-1/4" VC Hole	29.95
20825 Round Ball Milled - 1" VC Hole	29.95
20920 Oval Ball Milled 1-1/4" VC Hole	34.95
20929 Oval Plain - 1-1/4" VC Hole	34.95

BILLET PCV BREATHERS

21120 Plain 1-1/4" VC Hole	29.95
21125 Plain 1" VC Hole	29.95
21220 Bowtie 1-1/4" VC Hole	34.95
21320 Flamed 1-1/4" VC Hole	34.95
21520 Heartbeat 1-1/4" VC Hole	34.95
21720 Checkered Flag 1-1/4" VC Hole	34.95
21820 Round Ball Milled - 1-1/4" VC Hole	29.95
21825 Round Ball Milled - 1" VC Hole	29.95
21920 Oval Ball Milled 1-1/4" VC Hole	34.95
21929 Oval Plain - 1-1/4" VC Hole	34.95



ROUND BALL MILLED



BILLET HOSE ENDS

Machined from billet aluminum with polished finish. Sold each.



- 67025 5/16" Fuel - Braided 8.95
- 67225 3/8" Fuel - Rubber 8.95
- 67325 3/8" Fuel - Braided 8.95
- 67425 5/8" Heater - Rubber 10.95
- 67525 3/8" Heater - Braided 10.95
- 67625 3/4" Heater - Rubber 10.95
- 67725 3/4" Heater - Braided 10.95
- 67825 1 1/2" Radiator 17.95
- 67925 1 3/4" Radiator 17.95

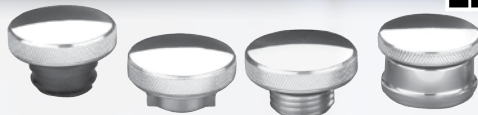

OIL FILLER CAPS

All machined from billet aluminum and available for a variety of applications. Weld-in style can be used by welding the bung to valve covers, aluminum tanks, etc... Weld-in bung is 6061-T6 aluminum and is 1-5/8" in diameter.

- 23120 Push-On 1-1/4" Valve Cover Hole 24.95
- 23220 Twist On 24.95
- 23320 Screw-On (Late GM) 24.95
- 24110 Aluminum Weld-in Bung 24.95

BILLET DIPSTICK

This functional dipstick uses an O-ring seal to eliminate leakage and blow-by. Designed to fit small block Chevy™ motors (up to '79) with drivers side dipstick.

- 40120 Billet Dipstick 19.95



THRU-FRAME FITTINGS

Machined from 303-stainless steel. Available for 2" & 2-3/8" wide frame rails. Sold in pairs only.

- 66210 -3AN x 1/8" NPT Short (2")
- 66310 -3AN x 1/8" NPT Long (2 3/8")
- per pair 29.95



NOTE: Size indicates outside diameter of hose

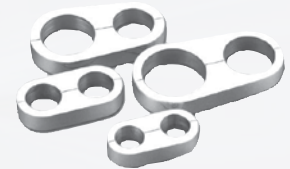

BILLET HOSE SEPARATORS

Machined from 6061-T6 aluminum and fully polished for adding a special detailed touch to any engine compartment. Sold separately.

- 68120 .500 x .500 9.95
- 68220 .562 x .562 9.95
- 68225 .562 x .625 9.95
- 68320 .625 x .625 9.95
- 68325 .625 x .781 9.95
- 68420 .734 x .890 9.95
- 68425 .734 x .969 9.95
- 68520 .781 x .781 9.95
- 68525 .781 x .906 9.95
- 68625 .890 x .969 9.95
- 68720 .906 x .906 9.95
- 68725 .906 x 1.015 9.95
- 68729 .906 x 1.125 9.95
- 68820 1.015 x 1.015 9.95

BILLET FUEL FILTERS

Designed for 3/8" fuel line and connects via a hose barb or 6-AN fitting. Available in smooth or ribbed styles for carbureted applications only. Mounting Bracket sold separately, uses common replaceable filter.

- (4 1/2" L x 1 3/8" Dia)
- 42120 Smooth Barbed 34.95
- 42220 Smooth -6AN 34.95
- 42320 Ribbed Barbed 34.95
- 42420 Ribbed -6AN 34.95

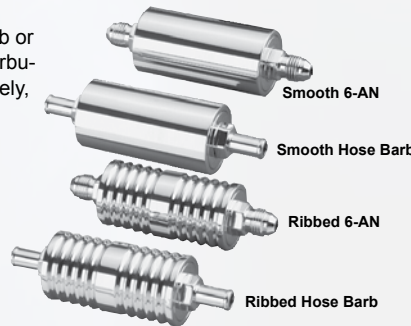

BILLET RADIATOR CAPS

These radiator caps have a machined billet top (see flamed for example) with knurled grip sides in your choice of 7 lb. or 16 lb. caps. Billet tops are packaged unassembled with the radiator cap to allow proper positioning of logo when you put it on your car/truck.

- 75120 Plain 16 lb. 19.95
- 75220 Circle 16 lb. 19.95
- 75320 Bowtie 16 lb. 19.95
- 75620 Heartbeat 16 lb. 19.95
- 75820 Flame 16 lb. 19.95
- 76120 Plain 7 lb. 19.95
- 76220 Circle 7 lb. 19.95
- 76320 Bowtie 7 lb. 19.95
- 76420 V-8 7 lb. 19.95
- 76620 Heartbeat 7 lb. 19.95



VACUUM ADVANCE COVER

Machined billet aluminum vacuum advance cover simply applies to vacuum advance unit with silicone. Polished finish.

- 88120 vv. 15.95

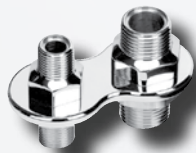

A/C Bulkhead



A/C & Push on Heater



A/C & Heater



FUEL PUMP BLOCK OFF PLATES

Designed to cover the fuel pump opening on small block or big block Chevy™ motors. Polished to a mirror finish - complete with stainless steel hardware.

41120 Small Block - Polished . . . 15.95

41220 Big Block - Polished 15.95

BILLET BULKHEADS

Heater bulkheads are designed to work with 5/8" heater hose. A/C bulkheads work with one #6 and one #10 A/C hose with O-ring fittings. All have a polished finish. (Fittings not included)

66720 A/C Bulkhead 2-port 39.95

66820 Heater Bulkhead 2-port 39.95

66825 Heater Bulkhead 2-port (push on) 39.95

66920 A/C & Heater Bulkhead 4 port 64.95

66925 A/C & Heater Bulkhead 4 port (push) 64.95



Push on Heater



Heater Bulkhead



BILLET OVERFLOW TANKS

Constructed from billet aluminum these overflow tanks include adjustable mounting hardware that allows placement along the entire length of the tank. All tanks have a knurled and threaded cap with O-ring seal for easy removal. Lengths specified are of the tank, overall measurement is 1-1/2" longer than listed. Diameter is 2 inches.

77113 Smooth Overflow 13" - 10 oz. 74.95

77115 Smooth Overflow 15" - 13 oz. 74.95

77117 Smooth Overflow 17" - 16 oz. 74.95

77213 Ribbed Overflow 13" - 10 oz. 74.95

77215 Ribbed Overflow 15" - 13 oz. 74.95

77217 Ribbed Overflow 17" - 16 oz. 74.95



BILLET UNIVERSAL WIRE LOOMS

The two piece design fits all big block and small block Chevy™ and Ford® engines. The wire looms mount to the base of the valve cover with adjustable tabs. For center bolt applications, use the late model bracket kit to mount to the heads - sold separately. For use with 8 mm wires (14-3/4" L x 2 1/4" W)

69520 Ball Milled. 59.95

69523 Bowtie. 64.95

69525 Heartbeat 64.95

69528 Flamed 64.95

69529 Plain 59.95

69600 Late Model Bracket 9.95



SWIVEL THERMOSTAT HOUSING

All thermostat housing are machined from billet aluminum and feature a positive O-ring seal which eliminates the need for gaskets or sealant.

90120 Straight up. 34.95

90220 90 degrees 69.95

90320 15 degree 69.95

90420 45 degree 69.95



BILLET DISTRIBUTOR CLAMP

For small block and big block Chevy™ motors.

65920 Distributor Clamp 21.95



Interior Accessories



BILLET DOOR LOCK KNOBS

Machined from billet aluminum with 10-24 threads. Universal application. Smooth head or Ribbed. Sold per pair only

- 45910 Smooth 19.95
- 45920 Ribbed 19.95



BILLET ALUMINUM LIGHTERS

Fully functional with polished finish, available in two sizes which cover most domestic vehicles.

Short Lighters

- 264120 Smooth 14.95
- 264122 Ribbed 14.95
- 264123 Smooth Flame 14.95
- 264128 Ribbed Flame 14.95

Long Lighters

- 264220 Smooth 14.95
- 264222 Ribbed 14.95
- 264223 Smooth Flame 14.95
- 264228 Ribbed Flame 14.95

Shift pattern



Two Sizes!!
Four Styles!!

MANUAL SHIFT KNOBS

Available in two thread sizes and four styles. These billet knobs will fit shifters with either 3/8" -16 or 10 mm x 1.5 threads.

10 mm x 1.5 Knobs

- 265120 Shift pattern 24.95
- 265122 Bowtie 24.95
- 265220 Shift pattern ribbed 29.95
- 265220 Bowtie ribbed 29.95

3/8" - 16

- 265230 Plain 24.95
- 265232 Bowtie 29.95



BILLET BEZEL A/C VENT

Billet aluminum bezel with black plastic vent louvers. Fully adjustable, attaches to 2-1/2" round flexible hose. Dash opening should be 2-1/2" in diameter.

- 38110 21.95



Mirror Head Dimensions

- Round 3-1/8" Dia
- Sm. Rectangle 1-3/4" x 4"
- Lg. Rectangle 1-3/4" x 5-1/4"
- Oval 2-5/16" x 4-3/16"

BILLET MIRROR HEADS

The mirrors are machined from billet aluminum and feature a stainless steel swivel supported by nylon inserts which provide smooth accurate adjustments that stay in position and look great while doing it.

- 73120 Round 34.95
- 73320 Sm. Rectangle 39.95
- 73420 Lg. Rectangle 44.95
- 73520 Oval 49.95



door handle

window crank

vent window crank

BILLET DOOR HANDLES & WINDOW CRANKS

Fully adjustable and easy to use: mount the spine on the regulator, slide on the aluminum cover, align the arm, tighten, and snap on the dome cover. Available in polished finish only. Sold by the pair.

Billet Door Handles

- 45520 GM '49 & up 59.95

Billet Window Cranks

- 46520 GM '49 & up 59.95

Billet Vent Window Cranks

- 47520 GM '49 & up 59.95



Classic Vintage Smooth

BILLET DASH KNOBS

Universal fit, with a 3/16" bore and set screw. Polished finish only. Sold per knob.

- 26001 Vintage 8.95
- 26002 Classic 8.95
- 26003 Smooth 8.95

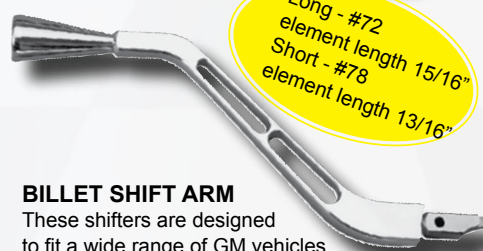

Long - #72
element length 15/16"
Short - #78
element length 13/16"

BILLET SHIFT ARM

These shifters are designed to fit a wide range of GM vehicles (except Van column) Easy installation.

- 267320 '69-94 Pass 69.95
- '73-94 Truck 69.95
- 269520 '95-98 All 69.95

Exterior Accessories



MIRROR ARMS

- 72520 4-1/2" Straight Arm LH 19.95
- 72525 4-1/2" Straight Arm RH 19.95
- 72620 5-1/2" Straight Arm LH 19.95
- 72625 5-1/2" Straight Arm RH 19.95
- 72720 Bent Arm LH 24.95
- 72725 Bent Arm RH 24.95

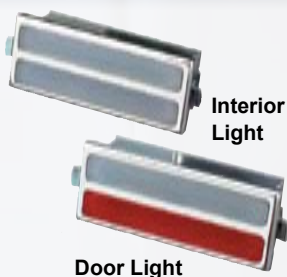

BILLET INTERIOR & DOOR LIGHTS

Designed for use in door panels, consoles and headliners. The interior and Door lights provide ample light for both RH & LH sides. Polished Finish. 1-1/2" H x 3-5/8" L x 2" D

- 60120 Interior Light 34.95
- 60220 Door Light 34.95



ELLIPTICAL 3RD BRAKE LIGHT

Our elliptical 3rd brake light can be molded right into the body. The extra bright lens is wrapped in a polished billet aluminum housing for a secure precision fit.

- 62520 54.95



Oval 7"W x 1-3/4"H x 1"D

OVAL 3RD BRAKE LIGHT

Protect your assets with this billet aluminum 3rd brake light. Oval style features a swivel base to adjust to rear window angle and mounts easily on rear deck.

- 62220 49.95

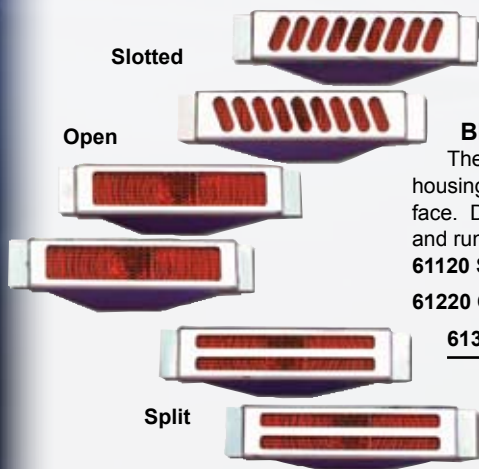

A MUST HAVE !

BILLET BEZEL TAILLIGHTS

These taillights feature a 3-3/4" deep steel housing and a 1-1/2" H x 6" W billet aluminum face. Dual element bulb for brake/turn signal and running light functions.

- 61120 Split 99.95
- 61220 Open 99.95
- 61320 Slotted 99.95



ELLIPTICAL INTERIOR & DOOR LIGHTS

Keep the smooth lines of your interior intact with these elliptical interior and door lights. Polished finish. 4" W x 2" H x 1" D

- 60320 Interior Light 34.95
- 60420 Door Light 34.95



Large 6" W x 2-1/8" H x 4" D
Small 4" W x 1-3/4" H x 4" D

ELLIPTICAL TAILLIGHTS

Extra bright lenses make them as functional as they are cool. Small lights are perfect for mounting in fenders. Dual element bulbs for brake/turn signal and running light functions.

- 61420 Large 134.95
- 61520 Small 134.95

Dash Inserts

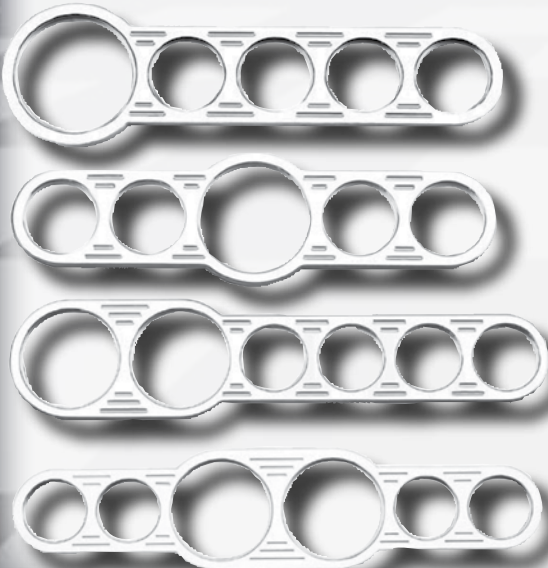

UNIVERSAL DASH INSERTS

- Designed for use with VDO or Autometer gauges. Choose from 3-1/8" or 3-3/8" gauge dia. Small ga holes are 2-1/16". NOTE: Stewart Warner and Classic gauges can be used with 3-3/8" dia dashes but will sit on top of the panel because of their large bezel size.

5 GAUGE PANELS

- 36120 3-1/8" Side 59.95
- 36125 3-3/8" Side 59.95
- 36220 3-1/8" Center 59.95
- 36225 3-3/8" Center 59.95

6 GAUGE PANELS

- 36320 3-1/8" Side 69.95
- 36325 3-3/8" Side 69.95
- 36420 3-1/8" Center 69.95
- 36425 3-3/8" Center 69.95



Dash Inserts



5 GAUGE RECESSED DASH WIDE
13-3/4" W x 4-1/2" H x 5/8" D
37120 Polished.....119.95



6 GAUGE RECESSED DASH WIDE
17-3/4" W x 4-3/4" H x 5/8" D
37120 Polished.....119.95

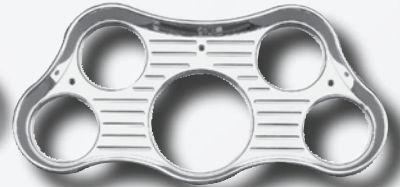

5 GAUGE RECESSED DASH STACKED
12" W X 5-3/4" H X 5/8"D
37220 Polished.....119.95



RIBBED RECESSED DASH
18-1/2" W X 6" H X 1/2"D
Indicator lights not used with this dash unit. Polished
37620.....275.00



CHEVY DASH PANELS

Available in 3-1/8" gauge diameters for VDO and Autometer gauges. Easy to install. Gauges mount from rear only. Polished Finishes only.
35220 '34-35 Chevy.....89.95
35320 '37-38 Chevy.....89.95



Steering Wheels

All our steering wheels feature milled finger notches on the backside of the grip ring, a flawless finish, and are all 14" in diameter. Pick the horn button and wrap that best fits your style.

- White
- Tan
- Light Gray
- Dark Gray
- Red
- Burgundy
- Blue
- Black
- Bone
- Simulated Carbon Fiber
- Simulated

To order a wheel you will need the following:

1. Wheel Name & Number
2. Leather Name & #
3. Horn Button Name & #
4. Adapter #

Leather Choices

- 29000 Blank - No Leather. 34.95
- 29001 White Leather. 44.95
- 29002 Tan Leather 44.95
- 29003 Light Gray Leather. 44.95
- 29004 Dark Gray Leather 44.95
- 29005 Red Leather 44.95
- 29006 Burgundy Leather 44.95
- 29007 Blue Leather. 44.95
- 29008 Black Leather. 44.95
- 29009 Bone Leather 44.95
- 29011 Sim Carbon Fiber. 59.95
- 29012 Sim Burlwood 59.95



29820 Eagle 399.95



30755 Hustler 224.95



30420 Vintec 399.95



30960 Flame 399.95



30970 Rebel 399.95



30765 Chi-Cayne 224.95

A steering wheel package consists of 4 pieces, the steering wheel, leather wrap, horn button, and adapter. Each piece is sold separately.



Billet Horn Buttons

The dome style buttons for the billet steering wheels and other aftermarket wheels with the 9-hole mounting pattern. These standard size horn buttons allow the mounting bolts to show.



- 32120 Plain..... 39.95
- 32320 Bowtie 44.95
- 32620 Billet Logo.....39.95



LARGE SMOOTHIE HORN BUTTONS

These horn buttons feature a larger flange that covers the mounting screws on the steering wheel. Like the standard buttons, they work with 9-hole type steering wheels.

- 32125 Plain..... 44.95
- 32325 Bowtie 54.95
- 32625 Billet Logo 44.95
- 32925 Banjo Style44.95



STEERING WHEEL ADAPTERS

We offer a wide line of steering wheel adapters to fit 9-hole type aftermarket steering wheels to various types of GM vehicle steering columns

(includes telescopic)

- 31120 1967-94..... 44.95
- 31126 1996-03 non airbag..... 54.95
- 31321 1955-56 54.95
- 31322 1949-66 (most applications) 54.95
- 31324 Telescoping 2" travel 69.95
- 31323 Telescoping 3" travel 69.95

Additional Wheel Choices



30825 Alien 224.95



30925 Banjo 259.95

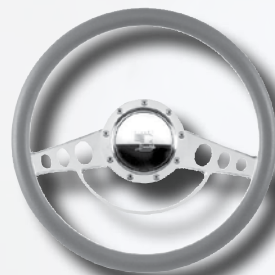

30725 Classic 224.95



29825 Eagle 224.95



30105 Eliminator 224.95



30965 Flame 224.95



30985 GT 224.95



30095 GT50 219.95



30935 GTX01 224.95



30075 Hollowpoint 224.95



29425 Indy 224.95



30065 Phantom 219.95

Additional Wheel Choices



30085 Pomona 224.95



30055 Psycho 224.95



29925 Revolver 224.95



30955 Sniper 224.95



30155 Spyder 224.95



30115 Twinspin 219.95



30145 Talladega II 224.95



30425 Vintec 224.95



30175 Fast Lane 224.95



30195 Street Star 224.95



30435 Rail 224.95



30445 Outlaw 224.95



30625 Dragster 224.95

To order a wheel you will need the following:

1. Wheel Name & Number
2. Leather Name & #
3. Horn Button Name & #
4. Adapter #

A steering wheel package consists of 4 pieces, the steering wheel, leather wrap, horn button, and adapter. Each piece is sold separately.



BILLET ALUMINUM DASH INSERTS for AutoMeter Gauges



1940-1946 Chevy Truck Billet Aluminum Dash Insert for Autometer Street Rod Series gauges (3 1/8" & 2 1/16")
11003 each.....139.50



1940-46 Chevy Truck Billet Aluminum Dash Insert for 3 3/8" Quads
11005 each.....145.00



1947-1953 Chevy Truck Billet Aluminum Dash Insert for Autometer gauges (3 1/8" & 2 1/16")
12003 each.....155.00



1947-1953 Chevy Truck Billet Aluminum Dash Insert for 3 3/8" Quads
12005 each.....110.00



1947-1953 Chevy Truck Billet Aluminum Dash Insert for 5" Quads (Autometer, Classic Instruments or Dolphin)
12006 set.....110.00



1954-1955 1st Series Chevy Truck Billet Aluminum Dash Insert for Autometer gauges (3 1/8" & 2 1/16")
12503 set.....150.00



1954-1955 1st Series Chevy Truck Billet Aluminum Dash Insert for 3 3/8" Quads
12505 set.....150.00



1954-1955 1st Series Chevy Truck Billet Aluminum Dash Insert for 5" Quads
12506 set.....150.00



1955-1959 Chevy Truck Billet Aluminum Dash Insert for Autometer gauges (3 1/8" & 2 1/16")
13003 each.....110.00



1955-1959 Chevy Truck Billet Aluminum Dash Insert for 3 3/8" Quads
13005 each.....129.50



1960-1963 Chevy Truck Billet Aluminum Dash Insert for Autometer gauges (3 1/8" & 2 1/16", 5 gauge)
14003 each.....125.00



1960-1963 Chevy Truck Billet Aluminum Dash Insert for Autometer gauges (3 1/8" & 2 1/16", 6 gauge)
14503 each.....123.00



BILLET ALUMINUM DASH INSERTS for AutoMeter Gauges



1964-1966 Chevy Truck Billet Aluminum Dash Insert for Autometer gauges (3 1/8" & 2 1/16", 5 gauge)
15003 each.....130.00



1964-1966 Chevy Truck Billet Aluminum Dash Knob Set (polished finish). Set includes: Headlight, Wiper, Lighter, Choke, & (2) Radio Knobs.
9700P set.....55.00



Billet Aluminum "Flame" Dash Insert for Autometer gauges (3 1/8" & 2 1/16")
92003 each.....185.00



1964-1966 Chevy Truck Billet Aluminum Dash Insert for Autometer gauges (3 1/8" & 2 1/16", 6 gauge)
15503 each.....130.00

See our AutoMeter Section for Gauges to Fit these Inserts



Universal Bowtie Dash Insert for Autometer gauges (3 1/8" & 2 1/16")
92103 each.....100.00



1967-1972 Chevy Truck Billet Aluminum Dash Insert for Autometer gauges (5" & 2 5/8")
16003 each.....199.95



Spline Sizes and Borgeson Equivalent			
Nominal Spline Size	Spline Diameter	Total number of Splines	Borgeson Designation
9/16-17	0.562	17	517
9/16-26	0.562	26	526
9/16-36	0.562	36	536
5/8-29	0.625	29	629
5/8-36 GM	0.625	36	636*
5/8-36 Chrysler	0.625	36	636C*
11/16-40	0.687	36	11/16-36
11/16-36	0.687	40	640
3/4-20	0.745	20	720
30	0.730	30	730
3/4-36	0.735	36	736
3/4-48	0.820	36	836
13/16-36	0.820	36	836
1"-48	0.985	48	148

Actual size may vary +/- 0.015" size listed. 636 & 636C are not interchangeable.

BORE STYLES

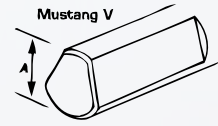
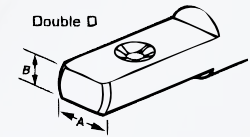

Double D Sizes and Borgeson Equivalent			
Nominal Size	Approximate Diameter (A)	Size Across Flats (B)	Borgeson Designation
17 mm Double D	0.670	0.570	6DD
3/4" Double D	0.750	0.550	7DD
1" Double D	0.993	0.790	1DD

Single Joint 15/8" x 31/4" up to 35° angle

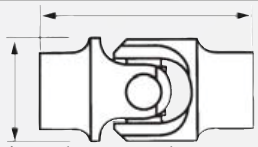

Double Joint 15/8" x 47/8" up to 70° angle

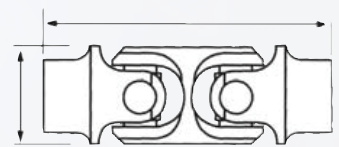

How to order:

Please use the charts and part number designations above to order your U-joint, or you can call our parts department and we will help you with your needs. We offer steel, stainless steel, or polished stainless U-joints in a single or double joint.

- Determine what you want on each end of your U-joint.
- Look up the appropriate part number from the chart listing part number designation or from the chart on the following page.
- Determine if your application requires a single or double joint and the desired finish.
- Use the suffix that correlates to the style and finish chosen.

Example:

736 748 - STS = 3/4" o.d. 36 Spline → 3/4" o.d. 48 Spline → Plain Steel → Single Joint
 7DD 730 - PSSTD = 3/4" Double D → 3/4" o.d. 30 Spline → Polished Stainless Steel → Double Joint

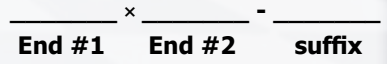

Suffix	Finish	U-Joint Style	Bore Style		
			Smooth + Smooth	Splined + Smooth	Splined + Splined
AL	Aluminum	Single	64.05	67.73	71.40
STS	Plain Steel	Single	64.05	67.73	71.40
SSTS	Unpolished Stainless Steel	Single	74.55	78.75	82.95
PSSTS	Polished Stainless Steel	Single	100.80	105.00	109.20
ALD	Aluminum	Double	128.10	131.78	135.45
STD	Plain Steel	Double	128.10	131.78	135.45
SSTD	Unpolished Stainless Steel	Double	148.05	152.25	156.45
PSSTD	Polished Stainless Steel	Double	186.90	191.10	195.30



Borgeson equivalency chart

Steering Columns					
	Application	Size	Spline Diameter	Number of Splines	Borgeson Designation
GM Column	Small Spline	3/4-36	0.735	36	736
	Large Spline	1-48	0.985	48	148
	Small Double D	3/4" Double D	0.750	-	7DD
	Large Double D	1" Double D	0.993	-	1DD
Other Manufacturers	International Column	1-48	0.985	48	148
	Ididit Column (Alum)	1-48	0.985	48	148
	Ididit Column (Steel)	1" Double D	0.993	-	1DD
	Ididit Column (Tel)	3/4-20	0.735	20	720
	Mullins Column	3/4-36	0.735	36	736
Steering Boxes and Racks					
Chrysler Box or Rack	Chrysler	9/16-17	0.562	17	517
	Chrysler	9/16-26	0.562	26	526
	Chrysler	9/16-36	0.562	36	536
	Chrysler	5/8-36	0.625	36	363C
	Chrysler	11/16-36	0.687	36	11/16/1936
	Chrysler	3/4-36	0.735	36	736
	Chrysler	13/16-36	0.820	36	836
	Chrysler Omni	9/16-26	0.562	26	526
GM Box Manual	Corvair	5/8-36	0.625	36	636
	Vega (Model 140)	5/8-36	0.625	36	636
	Corvette ('63-67)	3/4-30	0.728	30	730
	Corvette ('68-83)	3/4-36	0.735	36	736
	('58-64)	3/4-36	0.735	36	736
	Model 122 ('65-85)	3/4-30 or 3/4-36	0.730	30 or 36	736
	Model 525 ('86 & later)	3/4-30	0.728	30	730
GM Box Power	Model 605 ('78-84)	3/4-30	0.728	30	730
	Model 800 ('77 & earlier)	13/16-36	0.820	36	836
	Model 800 ('78 & later)	3/4-30	0.728	30	730
GM Rack	'79 & later	5/8-36	0.625	36	636
	Some Models	3/4-30	0.728	30	730
	Corvette ('84 & later)	17mm Double D	0.670	0.570	6DD
	Fiero	17mm Double D	0.670	0.570	6DD
Other Manufacturers	Heidt's Super Ride Rack	9/16-26	0.562	26	526
	Independent Chassis Rack	9/16-17	0.562	17	517
	Jaguar & MGB	3/4-48	0.750	48	748
	Kugel Rack	9/16-26	0.562	26	526
	Mullins Billet Aluminum	5/8-36	0.625	36	636
	Woodward Rack	3/4-20	0.735	20	720
	Nissan	11/16-36	0.687	36	11/16/1936
	Pacer (AMC)	Please measure diameter (either 636, 736, or 836)			
	Volkswagon-Rabbit Rack	11/16-40	0.687	40	640
	VW Rabbit Rack (Diesel)	3/4-36	0.735	36	736

Intermediate shafts

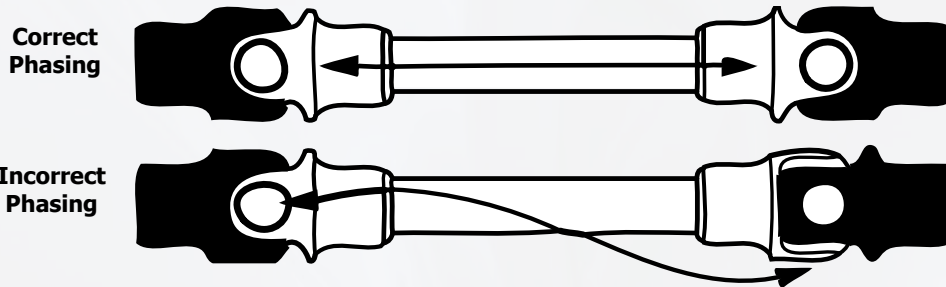

U-joint orientation

When two or more joints are used on a shaft the forks of the yokes closest to each other should be inline or "in phase". Premature wear or binding can result if the u-joints are not phased properly. If the u-joints are at a severe angle, even if they are phased correctly, a hard spot in the steering may occur for no apparent reason. If this happens, index the u-joints two or three splines in one direction. The hard spot should be minimized if not completely eliminated.

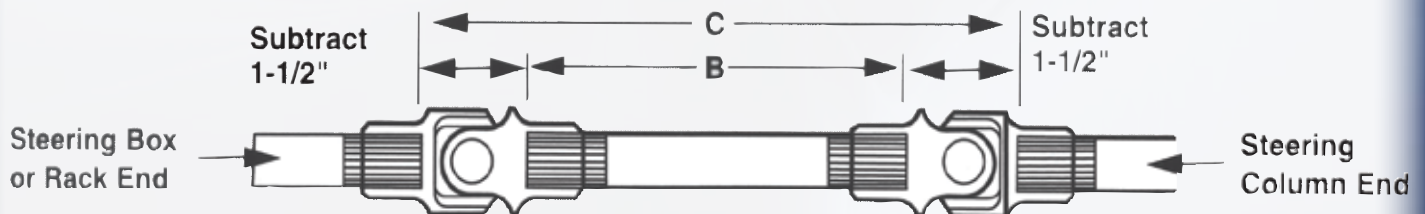

How to determine shaft length

With Two U-joints

1. Measure the distance from the end of the column to the box/rack (Dimension "C")
2. Subtract 3" from this measurement.
3. Order the next even size shaft (Dimension "B")
 Example: If "C" is 18" -- subtract 3" (1 1/2" for each joint). "B" is 15". Order a 16" shaft and trim a total of 1" from the shaft, either from one or both ends.

With One U-joint and U-joint/Vibration Reducer Combination

1. Measure the distance from the end of the column to the box/rack (Dimension "C")
2. Subtract 4" from this measurement.
3. Order the next even size shaft (Dimension "B").
 Example: If "C" is 19" -- subtract 4" (1 1/2" for the u-joint and 2 1/2" for the vibration reducer). "B" is 15". Order a 16" shaft and trim a total of 1" from either end.

Determine Splined Shaft Length with Three or More U-joints

1. Buy the u-joints first.
2. Install a joint on the column and one on the box/rack.
3. Use dowels or PVC pipe and mock up the system around obstacles. Order the correct shaft lengths based on dowel or PVC lengths.



Intermediate Shafts



Splined shafts

Plain Steel				
Part #	Fitting Style	Length	Standard Increment	Price
S736X2	736 to 736	2"	N/A	19.43
S736X2	736 to 736	4-16"	2"	31.50
S736X2	736 to 736	18-36"	2"	34.13
S736X1	736 to 3/4" round	5", 16", 36"	N/A	19.95
For lengths in non-standard increments				
S736X2	736 to 736	2 +- 16"	Any	46.50
S736X2	736 to 736	16 + - 36"	Any	49.13
S736X2	736 to 736	36 +- 60"	Any	59.13
S736X1	736 to 3/4" round	0-36"	Any	34.95
S736X1	736 to 3/4" round	36 +- 60"	Any	44.95
Aluminum				
Part #	Fitting Style	Length	Standard Increment	Price
AL736X2	736 to 736	4-16"	2"	39.38
AL736X2	736 to 736	18-36"	2"	42.79

Stainless Steel				
Part #	Fitting Style	Length	Standard Increments	Price
SS736X2	736 to 736	4-16"	1/4"	39.38
SS736X2	736 to 736	17-36"	1"	42.79
For lengths in non-standard increments				
SS736X2	736 to 736	4-16"	Any	62.61
SS736X2	736 to 736	17-36"	Any	67.87
Polished Stainless Steel				
Part #	Fitting Style	Length	Standard Increments	Price
SSP736X2	736 to 736	4-16"	1/4"	55.13
SSP736X2	736 to 736	17-36"	1"	58.54
For lengths in non-standard increments				
SSP736X2	736 to 736	4-16"	Any	78.36
SSP736X2	736 to 736	17-36"	Any	83.62



Unsplined shafts

Plain Steel			
Part #	Description	Increment	Price
UNSPSH	3/4" Unsplined Shaft	Per Foot	7.88
CUTOFF	Cut-Off Charge	Per Cut	10.50

Double D shafts

Plain Steel			
Part #	Fitting Style	Length	Price
S7DDX18	Double D to 3/4" round	18"	15.89
S7DDX18	Double D to 3/4" round	36"	21.23
S1DD	1" Double D Tube	36"	41.84
Stainless Steel			
Part #	Fitting Style	Length	Price
SS7DDX22	Double D to 3/4" round	22"	42.79
SS7DDX36	Double D to 3/4" round	36"	57.75
Polished Stainless Steel			
Part #	Fitting Style	Length	Price
SSP7DDX22	Double D to 3/4" round	22"	55.13
SSP7DDX36	Double D to 3/4" round	36"	58.54

Couplers & Adapters

COUPLERS

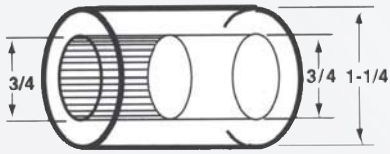

C736 - 3/4" 36 Spline x 3/4" smooth

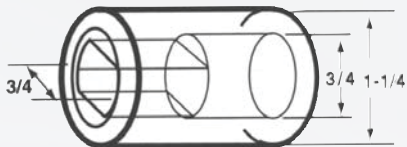

7DD - 3/4" DD x 3/4" smooth

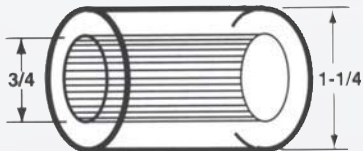

C736x2 - 3/4" 36 Spline only

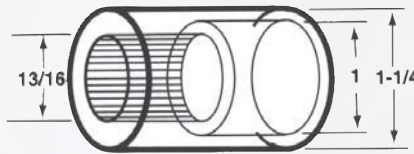

C836 - 13/16" 36 Spline x 1" smooth

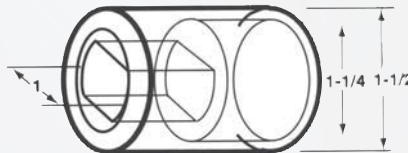

C1DD - 1" Double D x 1-1/4" smooth

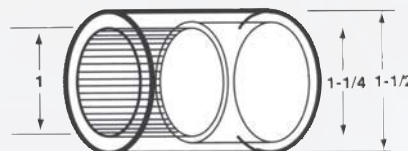

C148 - 1" 48 x 1-1/4" smooth

ADAPTERS

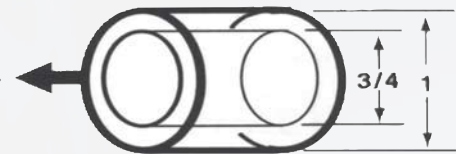

A-10R - 3/4" I.D. X 1" O.D.

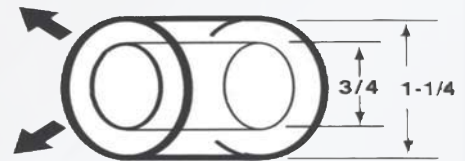

A-12R - 3/4" I.D. X 1-1/4" O.D.

Often a u-joint can be eliminated or placed in a more desirable location by using a 2" extension called a coupler to extend either the steering box, rack and pinion shaft or the column shaft. The 1" x 48 Spline and 1" x DD Couplers have a 1 1/4" hole that will accept an adapter to reduce I.D. to 3/4" smooth bore. The couplers requiring an adapter would have to be pinned or welded together. All couplers and adapters are available in stainless steel or polished stainless steel.

Couplers

Description	Stainless Steel		Polished Stainless Steel	
	Part #	Price	Part #	Price
3/4" 36 Spline x 3/4" Smooth	C736	23.10	C736SS	38.85
13/16" 36 Spline x 1" Smooth	C836	23.10	C836SS	38.85
3/4" DD x 3/4" 36 Spline	7DD	23.10	7DDSS	38.85
3/4" 36 Spline x 3/4" 36 Spline	C736X2	26.78	C736X2SS	42.53
1" 48 x 1 1/4" Smooth	C148	31.50	C148SS	47.25
1" DD x 1 1/4" Smooth	C1DD	31.50	C1DDSS	47.25

Adapters

Description	Plain Steel		Stainless Steel		Polished Stainless	
	Part #	Price	Part #	Price	Part #	Price
3/4" I.D. x 1" O.D.	A-10RS	7.54	A-10RSS	8.93	A-10RSSP	24.68
3/4" I.D. x 1 1/4" O.D.	A-12RS	7.54	A-12RSS	8.93	A-12RSSP	24.68



Vibration reducers

Vibration Reducers: Vibration reducers are used to cut down on the vibrations of the road that is transmitted to the steering wheel. These inline reducers are available with the following coupler ends:

Female End	Part Number
9/16" - 26 Spline526
5/8" -36 Spline.....	.636
3/4" -30 Spline.....	.730
3/4" -36 Spline.....	.736
3/4" -Double D7DD

Male End	Part Number
3/4" -36 Spline.....	Male Stub



Vibration reducers have a stainless non-polished cover. Polished covers are also available. Vibration reducers are available with a female/female, female/male, or male/male combination. Please use the part numbers to the left and the part number format below to order.

VR-_____x_____ use this format for non-polished reduces

PVR-_____x_____ use this format for polished reducers

Example 1: "VR-526xMale Stub" is a non-polished stainless steel vibration reducer with a 9/16"-36 spline female on one end and a male stub 3/4"-36 spline on the other.

Example 2: "VR-730x7DD" is a non-polished stainless steel vibration reducer with a 3/4"-30 spline female on one end and a 3/4" Double D female on the other.

Example 3: "PRV-736x736" is a polished stainless steel vibration reducer with a 3/4"-36 spline female on both ends.

Note: Only the cover is polished.

All Non-Polished Vibration Reducers **63.00**

All Polished Vibration Reducers **78.00**

Vibration reducer/u-joint combination

Vibration reducer/U-joint Combination: The vibration reducer/u-joint combination comes with the same available sizes on the coupler end as the vibration reducers, and is available with any spline or Double D size on the u-joint end. You must refer to the table that lists all of the part number designations for u-joints to choose the proper number for the u-joint end of this item. You must also use the chart for vibration reducers to choose the proper number for the coupler end. These are available in plain steel, stainless steel, or polished steel. The suffix will determine what type of metal it is made of.

Suffix Key

S = Plain Steel

SS = Stainless Steel

PSS = Polished Stainless Steel

VUJ_____x_____ - _____
 U-joint end Coupler end Suffix



Example: "VUJ-517x636-PSS" is a vibration reducer/u-joint combination in a polished stainless steel finish with a 9/16"-17 Spline on the u-joint end and a 5/8" spline on the coupler end.

Plain Steel **99.00**

Stainless Steel **114.00**

Polished Stainless Steel **159.00**



Support Bearings



Support Bearings: If more than two u-joints are used in a steering system, a support bearing must be used to prevent looping or binding. The support bearing must be mounted to the frame and not sheet metal. If your steering system has a double u-joint and a single u-joint this counts as a 3 u-joint system and requires a support bearing. All support bearings have a 3/4" hole size. We offer rod end bearings with two jam nuts for mounting as well as aluminum support bearings that are 2 1/2" long with two threaded holes in the end for mounting.



Description	Part #	Price
Plain Rod End Bearing	REB-PL	28.00
Stainless Rod End Bearing	REB-SS	69.00
Polished Stainless Rod End Bearing	REB-PSS	84.00
Aluminum Support Bearing	SB-AL	39.00
Polished Aluminum Support Bearing	SB-PAL	54.00



Note: 3/4" Double D shafts will work with the above support bearings.

STEERING BOXES



SAGINAW 525

Brand new OEM and rebuilt units are available. The GM 525 steering box is a stout unit that has with stood the test of time. GM started producing this box in the 50's and still uses versions of it for production vehicles today. The GM 525 steering box is available with a 1" or a 3 1/2" long input shaft with 16 to 1 or 22 to 1 steering ratios. All Mullins boxes have a three year warranty.

New

920010. 299.00

GM 140 BILLET BOX

Designed as a direct replacement for the GM 140 Vega steering box but with a stylish case CNC machined out of solid 6061-T6 billet aluminum. Sector shaft diameters, input shaft splines, and mounting bolt patterns are all the same as the standard 140 box so it is an easy, no hassle bolt-on. Available with a machined or polished finish. Stainless steel nut and pitman arm are sold separately. Machine Finish

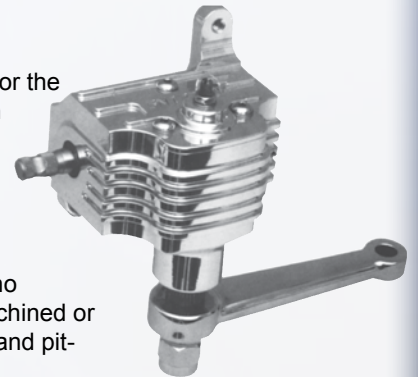

920001. 675.00

GM SAGINAW 605 POWER STEERING BOX

The 605 is used in many applications where space is a concern. The smallest power steering box from Saginaw has approximately a 16 to 1 constant ratio. Why waste your time and trouble getting a unit out of the junk yard that might be shot, when you can get one from Borgeson with a warranty?

Rebuilt Saginaw 605 P/S Box 3/4-30 Flare

800100. 275.00

New Saginaw 600 P/S Box 16:1 Ratio 3/4-30 O-ring

800207. 549.00

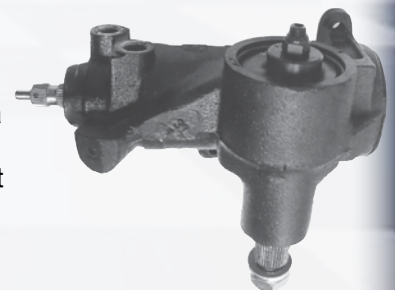



Borgeson rebuilds GM Saginaw power steering boxes to the same high standards that their needle bearing u-joints must meet. They totally disassemble each unit, chemically clean all parts, refinish the housings, thoroughly inspect all components, and replace any worn parts. Each is then carefully assembled and adjusted to factory specs.

Self contained saginaw gm power steering pump

These self-contained power steering pumps are available with either steel or aluminum pulleys. New and rebuilt to OEM specs. Brackets are available for most popular applications.

Chrome Rebuilt Self-Contained GM Pump with Keyway
800311..... 210.00

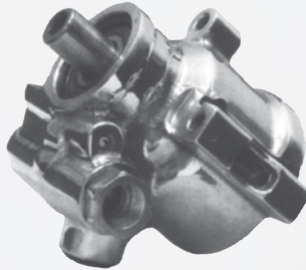

Power steering remote pump kit

All new GM aluminum pump includes: bracket, pulley, adjuster bar, type-2 for 'V' belt and type 3 for serpentine applications for small and big block Chevys. Pump sold separately.

Polished - Type 2 System
800500..... 158.00
 Polished - Type 3 System
800501..... 158.00



Stainless steel braided hose kit

Plumb your project with this stainless steel braided hose kit. No maintenance, won't rust, heat resistant, and is long-lasting. Pressure side uses a special high-pressure Teflon lined hose. Many fitting sizes and combinations for self-contained or remote systems are available. Tell us what you're working on and we can suggest the proper fittings.

Power steering remote pump

New aluminum pump made for Borgeson by Gm for street rod and custom applications. Specify cast finish or polished. Borgeson will preset the pump for required pressure.

GM PSI Slip-on End
800301..... 159.00

Stainless Steel Hose Kits		
Description	Part #	Price
GM self-contained pump to GM box	925103	59.00
Custom (please provide the info requested in spec chart) (3pc.)	925104	79.00
Custom (please provide the info requested in spec chart) (2pc.)	925105	69.00

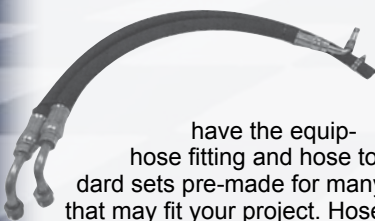

Custom made oem style rubber hose kits

One of the biggest pains when doing a custom installation is coming up with the right hoses. We

have the equipment to assemble any type factory swaged hose fitting and hose to your specifications. We also have many standard sets pre-made for many popular GM, Ford®, and Chrysler applications that may fit your project. Hose kits include fittings and any necessary mounting hardware as shown.

Hose Spec Chart	
The following information is needed for ordering a custom hose kit.	
Hose Type:	Rubber or Stainless Steel
Pump Type:	GM self-contained, GM remote, Other (specify)
If remote pump, reservoir type: Mullins, March, Street & Perf., Zoops, Other (specify)	
Box or Rack Type:	Specify
Hose Lengths:	Specify

Rubber Hose Kits		
Description	Part #	Price
GM self-contained pump to GM box (3pc.)	925203	129.00
Custom (please provide the info requested in spec chart) (3pc.)	925204	189.00
Custom (please provide the info requested in spec chart) (2pc.)	925205	149.00



MITY-TIDY® HOOD RELEASE KICK PANEL MOUNT

This kit is designed for fiberglass or metal. Contains Tie-Flex® cable system, all hardware and instructions.

MT-4H54.99

BUBBA BILT STREET ROD PRODUCTS



MITY-TIDY® INTERIOR DOOR RELEASE MT-1 KIT IS FOR TWO DOORS

The all new Mity-Tity® Interior Door Release offers something new in the market place. A new design only 1.61" by 2.81", making it ideal for any car or truck. Comes complete with left and right door releases, Tie-Flex® cable system for latches, all hardware and instructions. No question about it, it is the fastest and simplest system on the market. Why pay more? Works great, looks super and saves money!

MT-1 each89.99



All AMERICAN MADE! Guaranteed for the life of your car or truck!

STANDARD GAS DOOR RELEASE

The kit contains Tie-Flex® cable system, all hardware, and instructions. Guaranteed for life of car or truck. All American made.

SKG-317.99



EMERGENCY ENTRY SYSTEMS SUICIDE DOOR RELEASE

This system can be mounted in many locations. For example, in the truck pan for entry in case of electric or mechanical problems. The kit contains Tie-Flex® cable system, all hardware, and stationary mount with inner-pull knob. Connects from outside to door latch on suicide door cars. Guaranteed for life of car or truck. All American made.

BB-1943 (10') each37.99



EMERGENCY ENTRY SYSTEMS FOR SHAVED HANDLE TRUCKS

This kit makes it possible to open the door from outside in case of electrical or mechanical problems. Get back inside your car before you can use a cell phone to call for help. Kit contains stainless steel billet door loom, connecting door and 'A' post, Tie-Flex® cable system, and all hardware with pull knob. The system connects from outside (your choice of location) to door latch. Guaranteed for life of car or truck. All American made.

BKD-1 (8') each38.99

New TIE-FLEX® Cable System!
No turn too tight!

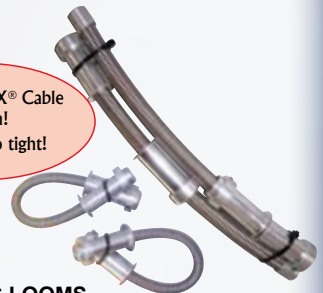

DOOR WIRING LOOMS

Door wiring looms connect wiring from 'A' post to door. Available in 1/4" and 1/2". (5/16" available by special order) Parts are designed for fiberglass or metal cars and trucks. Each loom consists of polished fittings for door and 'A' post. Teflon interliner for wire protection. (Plastic inner liners will break down with use) Teflon is covered with braided stainless steel.

LSS-25 (1/4") each36.99



MITY-TIDY® INTERIOR DOOR RELEASE KICK PANEL MOUNT MT-2 KIT IS FOR TWO DOORS

This kit is designed for the customer that wants a smooth door panel. The door release is mounted in the kick panel and is carried from 'A' post through doors by stainless steel billet looms, connecting to the door latch. Contains Tie-Flex® cable system, all hardware and instructions.

MT-2 each149.99

Please note: This kit is ideal for suicide door cars. Mount in 'B' post for example.



EMERGENCY ENTRY SYSTEMS GAS DOOR RELEASE

The kit contains Tie-Flex® cable system, all hardware, and instructions. Guaranteed for life of car or truck. All American made.

BKG-3 (8') each31.99



HOOD RELEASE

8" in length, Tie-Flex® cable system, all hardware to mount inside (under dash or through dash, kick panel) with stationary mount and inter-pull knob connecting to hood latch. Like all of their products, guaranteed for life of car or truck. All American made.

BKH-4 each36.99



BILLET DASH KNOBS

Available in three diameters: 1/4" and 3/16". (1/8" available by special order)

KNOB-190 (3/16") each4.99
KNOB-250 (1/4") each4.99





TUBULAR V8 ENGINE & TRANSMISSION CROSSMEMBER KITS



When a V8 is swapped into an early truck, a modern transmission soon follows. Our engine and transmission crossmember kits are cut-to-fit bolt-in units. The engine kit will accept small and big block motors, while the transmission kit accepts Powerglide, Turbo 350, 400, and 700R4 automatics. Mount pads sold separately. Transmission crossmember fits 26" to 36" frame rail spacing. Engine crossmember can be cut to fit 24" and extended to fit 37" wide frame rail spacing. Note: *Not designed to work with IFS front end. Transmission & Engine Crossmember kit (includes rubber motor & transmission mounts).*

TRANSMISSION & ENGINE CROSSMEMBER KIT
(Includes rubber motor & transmission mounts)
1947-59 Chevy Pickup
4759ETX-K125.00



REAR MULTI LEAF SPRING CONVERSION KIT
Want a smoother more comfortable ride? Start by replacing your worn-out rear leaf springs with one of our sturdy conversion kits. Kit includes drop springs, shock kit, brackets, shackles, hangers U-bolts, hardware and instructions.

1947-54 Pickup
4754RLK kit.....449.00

Leaf Spring Conversion Kit

Used to center the rear axle in the fender opening when installing a late model rear axle with stock leaf springs. Moves rear axle 1-1/2".

1947-53 Pickup
4753LSC-K pair.....29.00



REAR END COVERION KITS

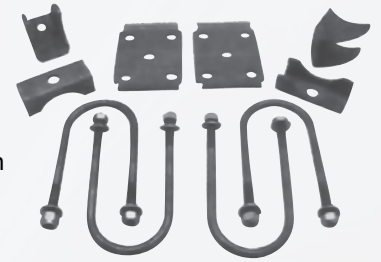

Our conversion kit allows you to update your existing axle to any 3-inch diameter rear, including GM 10- and 12-bolt, F-Body 7.5", Ford 9", or any other axle with 3" diameter axle tubes. Can also be used as a flip kit for a 4" to 5" drop. Welding is required. This kit also contains provisions for modern shock absorber mounting, a vast improvement over the original lever-action shocks.
1947-54 Pickup **4754RCK.....139.00**
1955-59 Pickup **5559RCK.....89.00**

REAR END COVERION KIT - 1960-72

Designed for adding a new rear axle, this kit is similar to #6072RCK but has the Deluxe Trac Bar #6572DBT-F in it and requires less welding to install. Kit includes axle brackets, adjustable trac-bar, U-bolts and nuts. For 1960-72 1/2 ton coil spring - truck only.
6072DRCK kit.....169.00



REAR MULTI LEAF SPRING CONVERSION KIT

This bolt-in kit is an ideal upgrade when you add a late model rear axle. Teflon leaf button for less friction and a smoother ride. Lowers vehicle 3-4" and features drop springs, shock kit, brackets, shackles, hangers U-bolts, hardware and instructions.

1955-59 Pickup
5559RLK kit.....449.00

Rear Lowering Block Kits

This is an easy and inexpensive way to lower your truck without affecting ride quality. Kits include aluminum blocks and new u-bolts

1960-72 Pickup
CP4-5 1/2 kit69.00
CP4-1 1" kit69.00
CP4-15 1-1/2" kit69.00
CP4-2 2" kit69.00





MONO LEAF SPRINGS

Our mono leaf springs meet or exceed multi-leaf specifications, are only 3/4" thick, and will lower ride height. They fit into the original shackles, are easy to install, and the kits come with bushings and U-bolts. Available in standard or reversed eye. Sold in pairs. New pins and shackles not included. NOTE: When installing a late model rear end into a 1947-53 chassis, our 1954-55 mono springs work best in centering the rear axle assembly between your wheelwells.

1947-53 Pickup

- 4" Drop Rear - 4753CTRS pair 428.00
- 6" Drop Rear - 4753CTRR pair 428.00

1954-55 Pickup

- 4" Drop Rear - 5455CTRS pair 428.00
- 6" Drop Rear - 5455CTRR pair 428.00

1955-59 Pickup

- 4" Drop Rear - 5559CTRS pair 428.00
- 6" Drop Rear - 5559CTRR pair 428.00

Lower the rear of your 1963-72 with a set of these new mono leaf springs. Designed to lower ride height either 4" or 5 1/2" these springs will provide a superior ride and improve handling. Springs bolt right into the original shackles for easy installation.

1963-72 Pickup

- Standard eye 4" drop - 6372CTRS pair..... 428.00
- Reverse eye 5 1/2 drop - 6372CTRR pair..... 428.00

Rear 5" Drop Kit

Kit includes 5" drop springs and shocks, Deluxe trac bar, U-bolts, hardware and shock relocation kit.
1965-72 Pickup
6572RDK kit.....329.00



Rear Traction Bar Kit

Our bolt-on rear traction bars help eliminate rear wheel hop and loss of traction under hard acceleration and braking. The front bar mount is fully adjustable allowing for the chassis setup to be fine tuned for any track conditions. Kit includes bars, leaf spring mounts, frame mounts polyurethane bushings and all hardware.
1955-59 Pickup 5559TBK kit.....189.00



Complete Deluxe Trac Bar Kit

This kit is designed for trucks lowered 4" or more. Includes 36" adjustable trac bar, with poly bushings and hardware. U-bolts and rear shock relocation kit.
1965-72 Pickup 6572CDTB-K kit.....169.00



Stock Suspension Rear Sway Bar

Sway bars are the key to having a great handling truck. They reduce body roll and help control over steer and under steer in corners. Kits come complete with sway bar, poly bushings, mounting brackets and all necessary hardware. 7/8" in diameter. Works on stock and flip kit applications as well as rear ends up to 3" in diameter. Note: Can be mounted on top or below rear end.
1947-59 Pickup CP169 kit.....169.00



1960-72 Heavy Duty Rear Sway Bar Kit

- Rear Coil Spring 1-1/8" CP7401 kit.....139.00
- Rear Leaf Spring 1-1/8" CP7402 kit.....159.00



Rear Deluxe Sway Bar Kit

We now offer a sway bar made specifically for our 4-link suspension kits, as well as our rear leaf spring kits. Bars are centerless ground to precise size then double heat treated and black oxide finished for durability. Mounting through the frame, the kit includes 7/8" diameter bar splined on both ends, splined polished aluminum arms and rod end linkage.

- 1955-59 Pickup
- Leaf Springs **CP413 kit**.....**259.00**
- 4-Bar (shown) **CP412 kit**.....**259.00**



Lowering & Handling Performance Kit

Includes front and rear sway bars, drop springs and shocks, brackets, bushings, hardware and adjustable track bar. 1965-72 Pickup **6572LHP-K kit**.....**599.00**

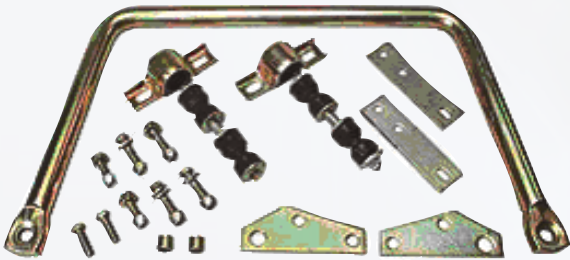

Stock Suspension Front Sway Bars

Sway bars are the key to having a great handling truck. They reduce body roll and help control over steer and under steer in corners. Kits come complete with sway bar, poly bushings, mounting brackets and all necessary hardware.

- 1947-54 Pickup (Front) 1-1/8"
- CP179 kit****139.00**
- 1955-59 Pickup (Front) 1"
- CP12030 kit****139.00**



3/5 Basic Drop Kit

Now our most popular drop components are available in one complete kit. Features 3" front and 5" rear drop springs and shocks, spindles, shock relocator kit and super trac bar. Note: Drop spindles require disc brakes. 1963-70 Pickup **6370BDK kit**.....**699.00**

Heavy-Duty Tie Rod & End Set

1" diameter tie rod and modern tie rod ends are an intelligent upgrade for any steering setup. These heavy duty parts are much more capable of handling today's grooved highways and radial tires than the original inferior 7/8" diameter "ball and socket" design parts. An absolute must when converting to power steering.



- 1947-54 Pickup
- 4754TRK set**..... **115.00**
- 1955-59 Pickup
- 5559TRK set**..... **115.00**



Mustang II Spindles

We offer new stock spindles and 2" drop spindles for the Mustang II IFS. Our spindles are the best on the market to date, forged from 1045 alloy steel and machined to OE specification. CPP spindles use all stock bearings and rotors and brackets for an easy installation.

- 1947-59 Pickup
- 2" Drop - M2DS pair**.....**195.00**
- Stock Height - M2SP pair**.....**195.00**



Spindles

Make your truck disc brake compatible with a set of our disc brake spindles. These are the same spindles sold in our OEM kits and upgrade kits. Cast from the highest quality Ductile Iron with 4140 Chrom-moly CNC machined pins. Accepts factory ball joints and tie rod ends. Designed to use 1971-87 1-1/4" rotors, calipers and bearings.

1960-62 Pickup C10

Stock Height	CP4S8 set.....	239.00
2 1/2" Drop	CP4S1 set.....	239.00

1963-70 Pickup C10

Stock Height	CP4S9 set.....	239.00
2 1/2" Drop	CP4S2 set.....	239.00

1971-72 Pickup C10

Stock Height	CP4S10 set.....	239.00
2 1/2" Drop	CP4S3 set.....	239.00

1973-87 Pickup C10

Stock Height	CP4S5 set.....	239.00
2 1/2" Drop	CP4S4 set.....	219.00

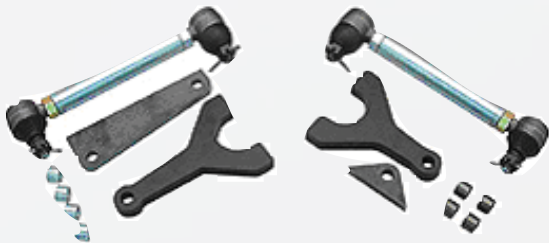

Power Steering Conversion Kit

This conversion kit allows you to install a late model (1969-87) Chevy 2WD pickup power steering box into your vintage 1947-59. Ideal for aftermarket tilt steering columns. Includes all brackets, instructions, and necessary hardware for installation. Power steering box and components are sold separately.

1947-54 Pickup	4754PSK kit.....	119.00
1955-59 Pickup	5559PSK kit.....	119.00

This package comes complete with two custom-made mounting brackets, hardware, and a steel sleeve that will connect the steering column shaft back together after it has been shortened. You can use any 1969-87 2WD, 1/2-ton steering box and power steering pump, also available from CPP.

1960-62 Pickup	6062PSK kit.....	95.00
1963-66 Pickup	6366PSK kit.....	95.00



1947-59 Power Steering Component Kit

Now you can have modern power steering for your vintage truck. Kit includes V8 power steering pump and brackets, gearbox and conversion kit, power steering pitman arm, hoses and hardware. Specify ride height and ratio desired.

1947-54 Pickup	4754PSK-S kit	699.00
1955-59 Pickup	5559PSK-S kit	699.00



1960-66 Power Steering Component Kit

Now from CPP the most complete power steering kit available. Kit includes pump and brackets, gearbox and bracket, power steering pitman arm, column coupler, rag joint and hardware.

1960-62 Pickup	6062PSK-S kit	725.00
1963-66 Pickup	6366PSK-S kit	725.00

Power Assist Steering Kit

This system is great for the purist. It bolts to the existing steering system and clears all of the factory components. This will allow the use of factory steering columns and allow for a stock look without having to suffer with manual steering. Kit includes power cylinder, drag link, heavy duty tie rod, new style tie rod ends, rebuilt control valve assembly, hoses and all necessary mounting hardware. Power steering pump not included. Note: 6 cyl. application require fabrication.

1947-50 Pickup	4750PSK-A kit.....	899.00
1951-54 Pickup	5154PSK-A kit.....	899.00
1955-59 Pickup	5559PSK-A kit.....	899.00





INSTRUMENTATION SYSTEMS

Dakota Digital Series III instrument systems offer the latest technologies and features for your custom vehicle. High brightness vacuum fluorescent displays provide a lifetime of trouble free use while offering increased accuracy and features!



DISPLAY COLORS



1940-46 CHEVY PICKUP

VFD System - Full 6 Gauge Instrument System includes Billet Aluminum dash housing as shown.

Panel dimensions - 12.25" x 4.3"

VFD3-40C-PU each 615.00



1947-54 CHEVY PICKUP (Including '55 First Series)

VFD System - Full 6 Gauge Instrument System includes new reproduction chrome bezels. Bezel Dia. 6"

1947-53 Pickup - VFD3-47C-PU set 615.00

1954 & '55 First Series Chevy Pickup - VFD3-54C-PU set 615.00



Does NOT fit GMC Pickup



Does NOT fit GMC Pickup

1955-59 CHEVROLET PICKUP

VFD System - Full 6 Gauge Instrument System fits into OEM bezel. Bezel sold separately.

VFD3-55C-PU set 525.00

1960-63 CHEVY PICKUP

VFD System - Full 6 Gauge Instrument System fits into OEM bezel. Does not fit GMC of the same year.

VFD3-60C-PU set 625.00



Does NOT fit GMC Pickup

1967-72 CHEVROLET & GMC PICKUP

VFD System - Full 6 Gauge Instrument System fits into OEM bezel. Available with or without clock. Bezel is sold separately.

(No Clock) VFD3-67C-PU set 625.00

(With Clock) VFD3-67C-PU-CLK set 699.00

1964-66 CHEVY PICKUP

VFD System - Full 6 Gauge Instrument System fits into OEM bezel. Does not fit GMC of the same year.

VFD3-64C-PU set 625.00



1973-87 CHEVROLET & GMC PICKUP

VFD System - Full 6 Gauge Instrument System fits into OEM bezel.

VFD3-73C-PU set 660.00



SPECIFY ON ANY DASH SYSTEM WHICH DISPLAY COLOR YOU WANT. BLUE OR TEAL.

DISPLAY COLORS

Digital rear view mirror

Digital compass temp rear view mirror

Rear view mirror with an outdoor temperature indicator and a Path Point Compass System™. Temperature indicator accurately displays from -31° to 131° +/- 3° F. Compass displays vehicle headings of **N, NW, W, SW, S, SE, E, and NE**. Great looking vacuum fluorescent digital display match Dakota Digital instrumentation packages as well. Switch on mirror selects temperature of compass reading. **Night Vision Safety™** feature also provides auto-dimming feature when dangerous glare from vehicles traveling behind you hit the mirror. Dimensions: 10.5" x 3.75". VFD compass/outdoor temp mirror (glue on style).



MMR-1 each **225.00**

Gearshift position indicator sending unit

The first universal, adjustable, gear shift indicator sending unit featuring automatic one button calibration.

CHECK OUT THESE FEATURES:

- Universal mounting hardware fits all automatic transmissions including Chevrolet TH350, TH400, 700R4, 4L60, 4L80, and powerglide; Ford® C-4, C-6, and AOD; Mopars and many others.
- Fully adjustable - No magnets to align! Each transmission position features an individual electronic adjustment.
- Neutral safety switch built in.
- Reverse back up light circuit provided.
- Decoder unit can be mounted inside the vehicle for easy access to one button calibration.
- Compatible with all 12 volt common ground L.E.D. indicators as well as all Dakota Digital gear shift indicators and instrumentation systems. Will not work with Lokar indicators.

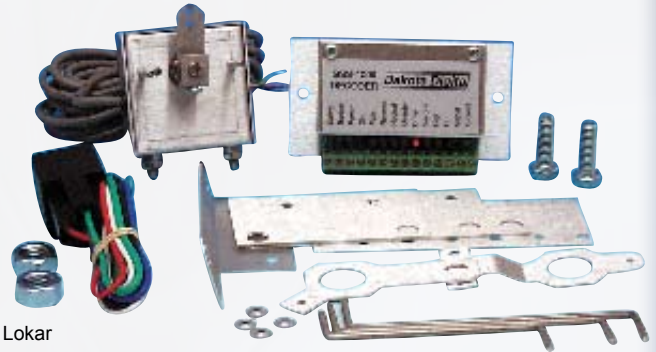

Each GSS-2000 kit includes: universal hardware pack, electronic sending unit, and gear shift decoder unit.

Universal gear shift indicator sending unit

GSS-2000 each **99.95**

Check out these package deals!

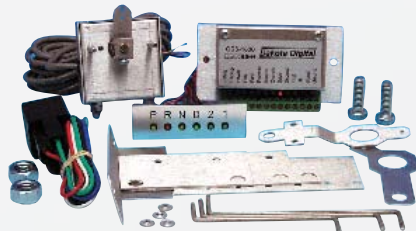

Individual multicolored L.E.D. indicators mount in an attractive dash mount panel. Indicator system is shipped with the GSS-2000 gear shift indicator sending unit. LED panel dimension 1" x 3"

GSS-2000 and multicolored L.E.D. indicators. Horizontal L.E.D. plate.

GSS-2002 each **119.95**

Vertical L.E.D. plate.

GSS-2002V each **119.95**

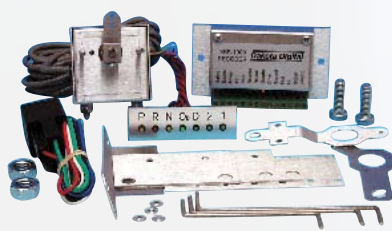

Individual multicolored L.E.D. indicators as in the GSS-2002 but with an extra indicator for "overdrive". Indicator system is shipped with the GSS-2000 gear shift indicator sending unit. GSS-2000 and multicolored L.E.D. with overdrive.

Horizontal LED plate

GSS-2003 each **119.95**

Vertical LED plate

GSS-2003V each **119.95**

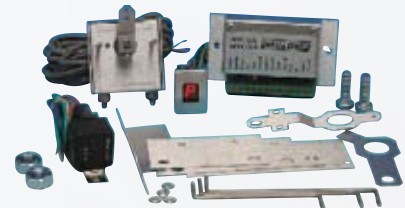

Brushed aluminum bezel with alpha numeric L.E.D. display and GSS-2000 package deal. Display unit is available in red, green, and amber.

GSS-2000 and red indicator
GSS-2004R each **155.00**

GSS-2000 and green indicator
GSS-2004G each **155.00**

GSS-2000 and amber indicator
GSS-2004A each **155.00**

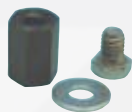

Kugel nuts

(For use with Kugel shift linkages.)

For all trans except 700R4 (std)

KN-3 each **8.00**

For 700R4 trans (metric)

KN-4 each **10.00**



Make your Original Truck Something Extraordinary!

Gearshift position indicator



Dgs-3 and dgs-4 gear shift indicators with turn signal, high beam, and auxiliary lights.



Gear shift position indicator

Expanding on the line of popular gear shift indicators, Dakota Digital is pleased to offer the all new DGS-3 and DGS-4! Both products feature automatic gear shift indication, turn signals, high beam indicator, and miscellaneous indicator to be used for check engine, 4WD, cruise control, security or anything else necessary! Available in several different color combinations, these units are sure to complement any application. Both products are situated inside fully machined aluminum housings, with the DGS-3 measuring 15/8" in diameter. The DGS-4 has taken design cues from their new elliptical shaped Ion Series and is a perfect match to that set, or even as a standalone unit.

For use with GSS-2000 gear shift sending unit.

DGS-3 each	99.95
DGS-4 each	99.95



L.E.D. Gear shift indicator

This innovative LED digital gear shift indicator displays shift position for both standard automatic and overdrive transmissions. Available in three different colors. Compatible with GSS-2000 sender.

Red digital shift indicator	
DGS-1R each69.95
Green digital shift indicator	
DGS-1G each69.95
Amber digital shift indicator	
DGS-1A each69.95

Universal speedometer signal interface

Universal speedometer signal interface

The Universal Signal Interface Unit can handle all of your electric speedometer signal conversion and calibration problems.

The SGI-5 can recalibrate 8K ppm-250K ppm electric speedometer pulse rates. Great for readjusting aftermarket and OEM electric speedometers on vehicles after changing rear end gears. **Not for use on vehicles with anti-lock braking systems.** The SGI-5 can also handle all of your speedometer pulse rate incompatibility problems. VDO Hall Effect Speedometer generator outputting 16K ppm and your cruise control requires a 2K, 4K, or a 8K pulse rate? No problem! Older GM 700R4 transmission outputting 4K ppm and your new cruise control requires 8K ppm? No problem! SGI-5 can also assist creating tach signals for diesel engines when using a flywheel gear-tooth sensor.



SGI-5 each79.95
-------------------------	---------------

Digital clocks



Digital clock displays time of day in 12 hour format. Available in blue, green, and teal with brushed aluminum, black anodized, or no bezel.

ODY-16-1 each	89.95
----------------------------	--------------

Displays more than the time of day. Includes date and day of week readout plus outside air temp in addition to 12 hour format clock. Senders included.

ODYR-16-1 each165.00
-----------------------------	----------------



Power accessory control

Digital climate control system

Dakota Digital is proud to release the DCC-2200 Digital Climate Control system designed for Vintage Air Gen-II Systems! Created to interface directly to a Gen-II Air Conditioning system, the DCC-2200 provides the convenience of full climate control. Similar to other Dakota Digital instruments, the DCC-2200 offers a full-character vacuum fluorescent digital readout for a simple and beautiful approach to updating your A/C system! Installation is nearly effortless with the addition of a pair of temp sensors, while plugging directly into the Gen-II wiring! Built in the USA, the DCC-2200 offers a full two year warranty!

DCC-2200 each99.95
----------------------------	---------------



Power accessory control

Programmable fan controller

The PAC-2000 was designed for the ultimate in flexibility and to be a simple add-on in any application using an electric fan with either single or dual fan configurations. Fully programmable, the PAC-2000 will work with your existing water temp gauge, operating from the temperature sending unit already installed! A dedicated sending unit can be installed for applications without a water temp gauge. The PAC-2000 features fully programmable "fan on" and "fan off" temperatures to suit any application or personal preference. The PAC-2000 can leave the electric fan operating after the engine has been shut down for a user adjustable time. The PAC-2000 offers a full digital LED readout for displaying temperature readings and maintaining simple installation.



PAC-2000 each	99.95
----------------------------	--------------

VSS Connectors



Transmission connector for Chevy 700R4
SEN-01-700 each19.95



Transmission connector for Chevy T-56
SEN-01-T56 each19.95



Transmission connector for Chevy 4L60
SEN-01-4L60 each19.95

Universal tachometer signal interface

Universal tachometer signal interface

The SGI-8 tachometer signal interface is designed to allow a factory tachometer to function accurately after performing an engine swap to an engine with a different number of cylinders or tach signal. For example - after a customer has swapped out their V-6 for a V-8 they can use the SGI-8 to recalibrate the tach signal from the V-8 to read accurately on the factory V-6 tachometer! This unit is capable of recalibrating tachometer signals for nearly any engine swap combination!



Universal tachometer interface unit SGI-8 each. 79.95

Cruise control



This is the only cruise control that will work with the high performance motors of street rods and sport trucks. This advanced electric servo cruise control uses solid state electronics for exceptional accuracy and reliability. It requires no vacuum and will work with radical camshafts and blown motors. Small and quiet enough to hide under any dash. A simple wiring harness and built in self-diagnostic check makes for exceptionally easy installation. Add the safety and convenience of cruise control to your vehicle today. 36 month/ 36,000 mile warranty.

For vehicles with cable driven speedometers: Includes electric servo, mounting hardware, wiring harness, electric speed sensor, and choice of control handle. Speed sensor attaches in-line with speedometer cable.
CRS-2000 each. 250.00

For vehicles with electric speedometers, or for use with Dakota Digital instruments: Includes electric servo, mounting hardware, wiring harness, and choice of control handle. Compatible with 2,000 to 40,000 pulse per mile speed signals. (Dakota Digital instruments use 8K ppm signals).
CRS-3000 each. 215.00

Cruise Control Handles

Cruise control handles

Each cruise control is supplied with your choice of the following control handles.

Universal Cutoff Handle

Secures to existing turn signal handle shaft.
HND-1 each 35.00

Dash Mount Switch

Can be secured to or under dash for hidden operation.
HND-2 each 45.00

Replacement GM Handle

Secures with single screw through flat end.
HND-3 each 35.00

GM "Push In" Handle

For most post '80 GM columns. No wiper controls.
HND-4 each 55.00

GM "Push In" Handle

For most post '80 GM columns. Wiper equipped.
HND-5 each 35.00

GM "Push In" Handle

For most post '80 GM columns. Wiper with delay.
HND-6 each 35.00

Ford® "Screw In" Handle

Ford® '83 and earlier
HND-7 each 35.00



Cruise Control Accessories



Aluminum cover for HND-1, HND-3, HND-4, and HND-7.

Polished aluminum finish
HNC-1-P each. 32.00

Brushed aluminum finish
HNC-1 each 26.00



Braided cable replaces black plastic cable in cruise control kits. Cables are "U-Cut-To-Fit" inside and outside to firewall.

Braided cruise cable for carbureted engines
LOK-1601 each. 62.50

Braided cable for Tune Port Injected engines
LOK-1603 each. 62.50



You've put nothing but the best parts into your hot rod, and spent a lot of time building your ride, and now it's time for a little luxury. Luxury at a price you can afford begins with a set of ELECTRIC-LIFE's Super Street Rod Power Window Kits. Installation is a snap with the easy to understand instructions, and if you can't read... give the pro's a ring, because we're motor heads, too. Then just sit back, press the switch and enjoy! Our Super Street Rod Kits are state of the art and will add that final custom touch to your vehicle. Included are all the necessary components that you will need to complete the job. Don't be fooled by the inferior knock-offs on the market - ELECTRIC-LIFE is the original manufacturer of the Super Street Rod Kit. They feature heavy-duty OEM quality Bosch/Unis motors, with screw cable drive. You deserve the best and we back it up with a lifetime warranty.

ELECTRIC-LIFE is an OEM manufacturer supplying power window systems to Ferrari, Lamborghini, Mercedes and Volvo, just to name a few. No other aftermarket power window manufacturer can make that claim. These are quality products for quality Rods.

Try a kit and see why over 50,000 Street Rodders say ELECTRIC-LIFE is simply the best out there!

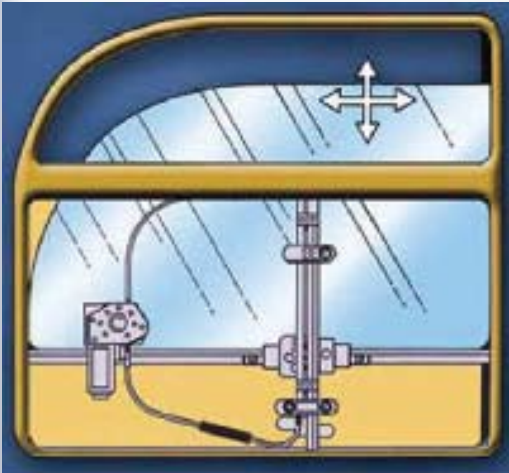

- The Super Street Rod kit is a complete regulator and motor assembly that can be installed in any vehicle originally equipped with straight glass.
- ELECTRIC-LIFE offers three different versions of the Super Street Rod Kit. Pick the style that suits your needs.
- The Super Street Rod Kit uses "OEM Style" motors for smooth, quiet operation.
- The Super Street Rod Kit contains all the necessary components to complete a 2-door installation.
- Super Street Rod Kits do not come with the switches, but they are listed on the following pages.

EL - Series Power Window Kits



The EL2000 differs from the other EL-Series kits in the way it mounts to the glass. This kit was truly designed for the DIY'er when it comes to ease of installation. The unit comes with a floating mounting head with 2 rubber isolated mounts that clamp directly to the glass. The unit is also self-containing, which ensures that the window is fully closed and seated in the sill. With the exception of the mounting system, our EL2000 is an exact replica of the EL1000.
 EL2000* kit325.00



The EL3000 is the slim line version of our EL2000. The EL3000 has the same chassis as the EL1000, with a newly designed roller bracket which offers "Z" axis motion allowing the regulator to follow the curvature of the glass. Even with its smaller size, the EL3000 has just as much power as the EL1000. It can be mounted in doors as narrow as 2"; a perfect solution for the Narrow door!
 EL3000* kit360.00



Application Specific Power Window Kits

- Complete with everything needed to install.
- 1930-35 Pickup** (use the EL-series kits)
 - 1936-46 Pickup**
P3946-16260-KT329.95
 - 1947-54 Pickup** (without Vent window)
P4850-16260-KT329.95
 - 1955-59 Pickup** (one pc front door)
P5559-16260-KT329.95
 - 1960-63 Pickup** with straight glass (use UL-series kits)
 - 1964-66 Pickup**
P6066-16260-K29.95
 - 1967-72 Pickup**
P6773-16260-KT329.95
 - 1973-87 Pickup & 1978-91 Suburban**
P7391-16260-KT329.95

Switches & Switch Kits



UNIVERSAL 2-DOOR ILLUMINATED CONSOLE OR DOOR PANEL MOUNT ROCKER SWITCH KIT
 Complete with 3 switches, 1 double bezel, 1 single bezel, wiring harness and connectors.
 4990-10-142 69.30



GM STYLE 2-DOOR CHROME SWITCH KIT
 Door panel mount - Kit comes complete with 1 double chrome switch pod, 1 single chrome switch pod and complete harness.
 4990-10-356 160.00



JOKER UNIVERSAL 2-DOOR ILLUMINATED DOOR PANEL MOUNT ROCKER SWITCH KIT
 BMW style complete with 3 switches, 1 raised double bezel, 1 raised single bezel, wiring harness and plug connectors.
 4990-10-421 84.97



DOOR PANEL MOUNT SWITCHES
 BMW Style Universal illuminated rocker switch kit. Comes complete with 3 switches, 1 raised double bezel, 1 raised single bezel, wiring harness and plug connectors.
 4980-31-009 59.40



UNIVERSAL 2-DOOR ILLUMINATED SWITCH KIT
 Mercedes style rocker switch kit. Complete with left and right console mount switches and wiring harness.
 4980-25-001 59.40



UNIVERSAL 2-DOOR ILLUMINATED CONSOLE OR DOOR PANEL MOUNT ROCKER SWITCH KIT
 Complete with 3 switches, 1 double bezel, 1 single bezel, wiring harness and connectors.
 4990-10-201 69.30



ECONOMY 2-DOOR POWER DOOR LOCK KIT
 An economical power door lock kit that offers similar features of our premium MES kits at an economy price.
 LK01-10-122E 102.00

ECONOMY 4-DOOR POWER DOOR LOCK KIT
 This kit has all the features of the Economy Door Kit with the benefit of operating all 4 doors.
 LK01-50-123E 155.00



Power Door Lock Kits



Convert your manual door locks to power door locks with the universal power door lock kit. This will convert any vehicle with manual door locks to central lock power door locks. Kits come complete with actuators, power door lock module, wire harness and a complete set of accessories for installation. Switches are not required due to the central locking power door lock module supplied in every kit.

- Converts manual door locks to full power.
 - Can be installed with or without keyless entry.
 - Easily integrated with most alarms or keyless entry systems.
 - Comes with complete mounting hardware.
 - Lock kits are supplied with plug and play wiring harness.
 - Complete the job by adding a Keyless Entry System.
- 4910-10-305 85.00

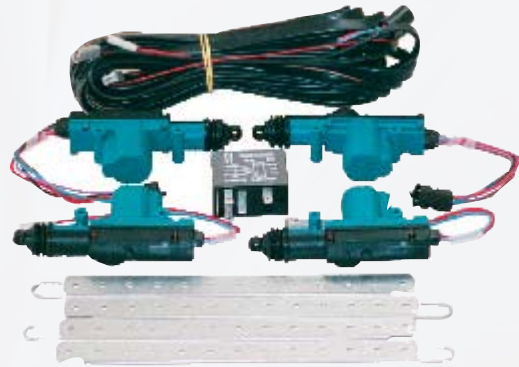

MES 4-DOOR POWER LOCK KIT

Comes with everything you need to convert your locks to power for all four doors.
 LK01-50-123 155.00



MES 2-DOOR POWER DOOR LOCK KIT

MES door locks are Swiss made, and are original equipment on Ferrari, BMW, and Mercedes Benz. When you're looking for the best, specify MES.
 LK01-10-122 102.00



POWER DOOR LOCK MODULE

The power lock module can be used to operate any reverse polarity motor. The module is triggered with (-) inputs, eliminating the need for multiple relays.
 3901-58-918 37.58



KEYLESS ENTRY/STARTER DISABLE SYSTEM

The ELECTRIC-LIFE Keyless Entry/Alarm module comes with 4 programmable channels.
 Features:

- 4 Programmable Channels
 - 2-4 Button Transmitters
 - Remote Panic (full time)
 - Separate Lock & Unlock Buttons
 - Starter Disable Output (built in relay)
 - Channel Pulsed Output
 - Sire / Horn Honk Output
 - 3rd & 4th Channel Pulsed Ground / Variable Output
 - Power Door Lock / Unlock Outputs
 - Driver's Door Unlock Output
- 95121..... 85.00



Keyless Entry & Door Lock Kits



STREET ROD



MANUAL DOOR LOCKS TO POWER REMOTE

Convert your old manual door locks to full power remote with this kit. The combination power door lock and keyless entry system will convert your old manual locks to full remote power. Comes with 2-4 button transmitters that can activate your locks from 100 feet away.

95120201.00



50 POUND DOOR SOLENOIDS

99004 pair123.75

99003 each66.00

MES 5 WIRE LOCK ACTUATOR

The most powerful trigger actuator available. This precision Swiss made actuator can pull an actual 12 lb. load and can operate any door lock. Comes complete with mounting hardware. Sold each.

4202-10-91026.40



STAINLESS STEEL DOOR PROPPER

Complete with rubber bumper, striker pad and adjustable plunger.

9959124.00



MES 2 WIRE LOCK ACTUATOR

The 2 wire MES actuator performs exactly like the 5 wire unit, and can be used to open door latches, hood latches or tailgate releases. Sold each.

4202-10-90923.10

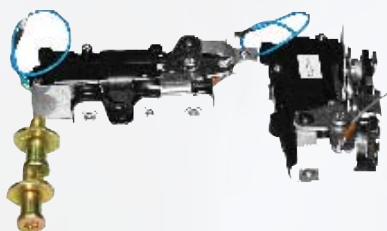

POWER BEAR CLAW LATCH KIT

This is the ticket for an award winning street rod. This kit is complete with left and right Bear Claw latches, attached power actuators, and manual cable release to insure a safe exit in case of power loss.

94000155.00

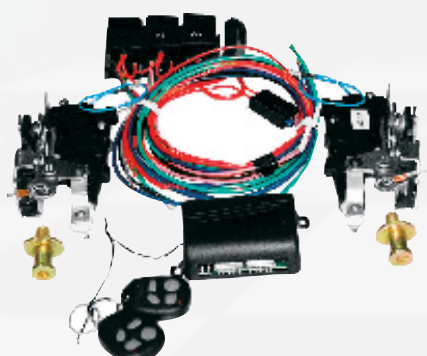

POWER BEAR CLAW SHAVED HANDLE KIT

Take that ride to the next level with our Power Bear Claw Shaved Handle Kit. Complete with left and right power bear claw latches, 4 channel keyless entry with two 4-button remotes and heavy duty plug and play wiring harness.

94100340.00



ECONOMY SHAVED DOOR HANDLE KIT WITH 12 LB MES ACTUATORS

Our Economy Shaved Door Handle Kit uses all the same components as our heavy duty kit except that we use our 12 lb MES actuators in place of the 50 lb solenoids. This kit will pop any late model door or Bear Claw latch. For early model vehicles with heavy latches use the Heavy Duty Kit.

99002180.00

BEAR CLAW MOUNTING KIT

When installing one of our power Bear Claw kits, don't forget to order our mounting kit for the striker bolt. This kit greatly simplifies the installation process, and will make quick work of lining up the latch with the striker bolt.

9410385.00



FLAMING RIVER

POWER TRU-TELESCOPIC COLUMNS

Unique design telescopes from the tube for driver comfort unlike bulky OEM designs. A two inch range of linear movement. Smooth linear activating device with stainless cable positions the column. Stainless steel piston and sleeve CNC machined for smooth action. Optional memory control for Driver 1 or Driver 2 positioning. Mounts like all Flaming River tilt columns ... easy!



Part #	Overall Length	Finish	Price
FR20011	30-32 in	Mill Finish	1100.00
FR20011PL	30-32 in	Polished Stainless	1350.00
FR20012	32-34 in	Mill Finish	1100.00
FR20012PL	32-34 in	Polished Stainless	1350.00

**Don't Mistake The Quality!
You Get What you Pay For**



Awarded Best New Safety Related Street Rod Product for 2003 by NSRA

MADE IN THE U.S.A.

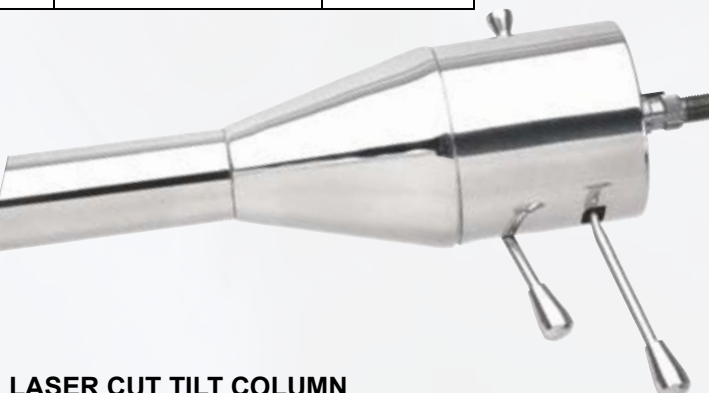

LASER CUT TILT COLUMN

Designed for safety and streamlined for a Street Rod. Intricate laser cut diamond pattern which enables the tube to fold upon impact with 4 inches of collapsibility. Center tilt shaft has a unique shear pin design which allows full collapsibility. Added safety and yet maintains an attractive appearance at an affordable cost. Manufactured on Flaming River's New Laser machining center at their Cleveland, OH facility.

Part #	Overall Length	Finish	Price
FR20005LC	30 in	Mill Finish	479.00
FR20005SSLC	30 in	Polished Stainless	569.00
FR20006LC	32 in	Mill Finish	479.00
FR20006SSLC	32 in	Polished Stainless	569.00
FR20007LC	35 in	Mill Finish	479.00
FR20007SSLC	35 in	Polished Stainless	569.00

COLUMN DROP WITH IGNITION KEY

Flaming River's popular radiused column drop is now available with an ignition switch! Ideal for small spaces and provides a convenient "key" accessory while dropping the column to the ideal position.

Drop	1-3/4" diameter	Price	2" diameter	Price
4-1/2	FR20104PLKY	189.00	FR20109PLKY	189.00
5-1/2	FR20105PLKY	132.30	FR20110PLKY	132.30
6-1/2	FR20106PLKY	132.30	FR20111PLKY	132.30



FLAMING RIVER



IGNITION SWITCH WITH COLUMN MOUNT

A new billet aluminum column mount with ignition key provides a stylish way to mount your column and key. The reversible design can mount the key on either side of the column.

Part #	Style	Price
FR20114KYPL	Column mount Polished Finish	144.00
FR20114KY-2PL	Column Mount with key and 12 V accessory Polished	194.00
FR20114SH-1	Shim to drop $\frac{3}{4}$ "	49.00
FR20114SH-2	Shim to drop $1\frac{1}{4}$ "	49.00
FR20114SH-3	Shim to drop 2"	49.00



STAINLESS BRAIDED HOSE KIT - REMOTE RESERVOIR STYLE

Includes stainless braided lines with fittings for installing Flaming River power rack and pinion with a remote reservoir. Simplifies installation with a clean, polished appearance.

FR1610 GM apps.....175.00



BILLET DASH MOUNT WITH IGNITION KEY

Relocate your ignition switch under the dash with the stylish billet aluminum mount. Easily bolts to stock dash for convenient mounting in limitless applications. Ignition switch & boot included.

FRIGN3PL Polished.....109.00

FRIGN3-1 Billet Mount Only.....79.00

BILLET DUAL MOUNT WITH IGNITION KEY AND ACCESSORY

FRIGN4PL Polished.....194.00

FRIGN4-1 Billet Mount Only.....139.00



SWING AWAY BRACKET & SWIVEL MOUNT KIT

This neat bracket kit enables you to mount a steering column and swing it to the side when entering or exiting the vehicle. It includes the bracket and swivel floor mount in 1 3/4" or 2" diameter. A column and column drop must be purchased separately. Can be used with your existing column.

FR1621 (1 3/4" diameter).....259.00

FR1622 (2" diameter).....259.00



The system includes:

- New power rack & pinion
- Pump with aluminum pulley
- Installed (v-belt or serpentine)
- Fittings for connecting hoses-can be easily connected to the hose kit of your choice.

POWER RACK



POWER RACK BILLET U-JOINTS

The Billet-Joint® Universal joint are CNC machined from aircraft steel to precision tolerances. The sealed needle bearing design will last ten times longer than a standard pin and block universal joint. The unique nickel plating prevents rust without the hassle of painting. Polishing available for a "stainless look" at a nominal

(3/4" DD)
FR1789P 85.90

(3/4" - 36)
FR1789-P2 85.90

(1" DD)
FR1789-P3 85.90

VARIABLE PRESSURE POWER RACK & PINION PUMP SYSTEM

The Flaming River power rack is the first new power rack designed with the street rodder in mind. The rack is only sold with the pump and pulley (available in V-belt or serpentine style) so the system is properly calibrated. The rack uses the Mustang II 16" center mounts, the FR1601 outer end and, of course, is dimensionally interchangeable with the 74-78 rack. However, the similarity ends there. This rack is an all new unit so the quality is very consistent. This new design features a partial chromed housing for an attractive cosmetic appearance. Rack is designed for maximum front end vehicle weight of 1,750 lbs.

FR1530-V V-belt design.....559.00

FR1530-S Serpentine belt design.....559.00

FRAME MOUNTS

These allow for easy mounting of support bearing. Slotted for adjustability.

FR1810KAC Angle Design85.00

FR1810KSC Straight Design.....85.00

FLAMING RIVER



REMOTE RESERVOIRS

Polished aluminum remote reservoir features threaded cap and two machined billet brackets for secure attractive mounting. Sleek, radiused design for a beautiful engine compartment. Recommended for use with Flaming River power rack system - it can also be used with other stage II pumps. Similar style available for Radiator Overflow and Master Cylinder Remote Reservoirs.

- FR1614 Power Steering..... 149.00
- FR1615 Coolant Overflow..... 179.00
- FR1616 Brake Fluid..... 149.00



MAGNETIC BILLET RESERVOIR

Features candy cane internal baffle to eliminate internal air pockets and prevent foaming. Adjustable Billet Aluminum brackets included for stylish and secure mounting. Internal threaded cap for smooth, sleek, radiused appearance.

New optional style available with internal magnet to attract any loose steel materials

- FR1614MA169.00

STEERING BOXES

VEGA BOX



The Flaming River Performance Vega style steering box is an all NEW unit designed specifically for street rods. This box is 30% stronger than the OEM box and utilizes the latest technology with a smooth needle bearing design. This new design far outlasts the original bushing design of the 70's. Direct Bolt-In Replacement - New Needle Bearing Design - Stronger Casting & Internals - One Year Warranty

The Vega-style box is preferred by most builders due to the steering geometry of straight axle equipped cars. We have dramatically improved the Flaming River Vega-style box.

- NEW high tech chromed cap included.
- Factory marked center position.
- Smooth needle bearing design for longer life
- Heavy-duty worm gear and roller bearing design is 30% larger than original for smoother, more comfortable steering end to end
- Crowned Sector - Higher torque at center position reduces vibration and provides for more natural return of steering wheel.

- FR1500 Steel..... 359.00
- FR1500Q Steel Quick Ratio 459.00
- FR1500C Chrome Steel..... 599.00

NEW POWER STEERING BOX

Trivalent Chromium Free Plating offers ten times the corrosion resistance of a painted box. Features Unique Tech billet cap included.

Rack and Pinion Valve Spool for SMOOTH, PRECISE steering and handling.

Four Bolt Mounting Pattern also interchanges to early three bolt application.

Available in four ratios (12:1, 14:1, 16:1, 17:1) to fit virtually any application with the steering feel you prefer. NOTE: Ratios are approximate - input shaft 3/4-30 spline

- FR1560 Power Steering box 12:1 ratio, plated w/ billet cap 489.00
- FR1561 Power Steering box 14:1 ratio, plated w/ billet cap 489.00
- FR1562 Power Steering box 16:1 ratio, plated w/ billet cap (OE ratio)..... 489.00
- FR1563 Power Steering box 17:1 ratio, plated w/ billet cap (OE ratio)..... 489.00



Integral Reservoir Pump

Reservoir features trivalent chromium free plating for corrosion resistance. Flow of 2.7 to 3.1 gallons per minute. Pump can be interchanged to earlier reservoir with o-ring adapter kit (FR15720R). Fits most popular GM applications.

- FR1572.....169.00



Variable Pressure Pump

Pressure reduces at higher RPM for maximum control during highway driving and easy steering in parking situations. Remote reservoir (FR1614) required.

- FR1570149.00



**ALL ITEMS PROUDLY MADE IN THE U.S.A.
You Get What You Pay For !**

shifters



UltraShifter 23"



UltraShifter 23"
Swan Neck Style



UltraShifter 12"

Also offered is a Rear Mount Shifter with a 12" Stick and Aluminum Knob (not pictured)

Part number	description	price
GS 1000-SPO	Ultra Shifter - 12"	219.95
GS 1001-SPO	Ultra Shifter - 16"	219.95
GS 1002-SPO	Ultra Shifter - 23"	219.95
GS 1003-SPO	Ultra Shifter Swan Stick	230.95
GS 1004-SPO	Rear Mount Shifter	186.95

YOU MUST SPECIFY A TRANSMISSION STYLE WITH THE PART NUMBER ABOVE TO INSURE A CORRECT MOUNT AND FIT.

You must specify when ordering a shifter what type of transmission you are using. Below are the available options.

GM Powerglide	GM TH350
GM 4L-60	GM 4L-80
GM TH400	GM 700R4
200R4	Mopar 727
Mopar 904	

boots & indicators



Hand Brake Boot Kit (Gennie hand brake)
Specify color
GS2004-SPO **24.95**

Hand Brake Boot Kit (Lo-Line Plus)
Specify color
GS2005-SPO **24.95**

Trans Shifter Boot (Specify Color)
GS1005-SPO **29.95**

Rear Mount Trans Shifter Boot (Specify Color)
GS1006-SPO **24.95**

Boot Indicator
GS1011 **82.95**

Lighted Rear Mount Indicator
GS1012 **71.95**

Dash Mount Indicator
GS1013 **71.95**



Boots are available in Black, Red, White, Tan or Maroon



AIR SERVICE AVAILABLE ON ANY ORDER. INQUIRE!

hand-brakes

All Handbrakes meet most D.O.T. & NSRA Specifications. Gennie handbrakes are designed to mount easily to any Gennie Ultra Shift Bracket.



Gennie Hand Brakes - 16" or 11"

Lo-Line Plus Hand Brake
Can be placed in almost
any location in the
vehicle



Gennie Hand Brake - 16"	
GS2001	109.95
Gennie Hand Brake - 11"	
GS2002	109.95
Lo-Line Plus Hand Brake	
GS2003	87.95

brake cables

Gennie Shifter provides a variety of Emergency & Parking Brake cable kits that can be used to connect you in almost any applications. Recommended by Wilwood Engineering for use in installing some of their rear parking brakes.



GS2006	GS-2 For Drum Brakes - Fits Gennie hand brake -This kit provides the hardware required to attach the Gennie Hand Brake (11" or 16") to cables that are compatible with most rear drum brakes.	98.95
GS2007	GS-1 - For Jag Rears - Fits Gennie hand brake - This kit provides the hardware required to attach the Gennie Hand Brake (11" or 16") to a single cable that is compatible with Jag rear ends.	54.95
GS2008	UN-2 - For Drum Brakes - Universal Design - This kit provides the hardware required to attach most parking brake handles (includes the Lo-Line Plus hand brake) to two cables that are compatible with most rear drum brakes.	98.95
GS2009	UN-1 - For Jag Rears - This kit provides the hardware to link most parking brake handles (including the Lo-Line Plus Hand Brake) to single cable that is compatible with jag rear ends.	54.95
GS2010	FF-1 - Fat fendered Single Cable to UN-2 - This kit provides a single cable and the hardware needed to connect an old style, under dash parking brake to a UN-2 cable kit.	47.95

BRAKE HARDWARE



Some applications require a clevis to properly attach the cables to different types of brakes. Gennie Shifter offers a selection of brake clevis kits.

GS2011	Cable Clamp Kit	8.95
GS2012	Clevis Kit 1/4" Pin	19.95
GS2013	Clevis Kit 5/16" Pin	19.95
GS2014	Corvette Clevis Kit	25.95





throttle & kickdown cables



GS3001	Standard Throttle Cable (works with electric 400 k/d)	32.95
GS3002	Braided Throttle Cable (works with electric 400 k/d)	41.95
GS3003	Throttle - Ultra Throttle Cable (includes #2 carb bracket)	43.95
GS3004	Stealth Throttle Cable	49.95
GS3005	Stealth 400 Cable (works with electric 400 k/d)	49.95
GS3006	T.P.I. - Standard (use with factory bracket)	46.95
GS3007	Throttle - Stealth T.P.I. (use with factory bracket)	46.95
GS3008	T.P.I. Machines Aluminum Bracket	32.95
GS3009	Ultra T.P.I. Cable (for aluminum bracket)	43.95
GS3010	Ultra Stealth T.P.I. Cable (for aluminum bracket)	46.95
GS3011	LT-1 Kickdown Bracket Kit	56.95
GS3012	Ultra Throttle LT-1	43.95
GS3013	Ultra Stealth Throttle LT-1	46.95
GS3014	Polished SS Mounting Bracket	11.95
GS3015	Standard Kickdown Cable (350 Only)	43.95
GS3016	Braided Kickdown Cable (350 Only) S. S. Fittings	54.95
GS3017-SPO	Ultra Kickdown Cable - Specify Transmission	54.95
GS3018	Ultra T.P.I. / LT-1 350 Kickdown Cable	54.95
GS3019	Ultra T.P.I. / LT-1 700 Kickdown Cable	54.95
GS3020	Kick Down - Electric 400	36.95
GS3021	Throttle Return Spring Kit	8.95

dipsticks



DIPSTICKS - Transmission and Engine

GS4001-SPO	Flexible transmission tube with machined aluminum dipstick - trans mount - specify transmission	61.95
GS4002-SPO	Flexible transmission tube with machined aluminum dipstick - firewall mount - specify transmission	61.95
GS4003	Engine dipstick - early Chevy small block	15.95
GS4004	Engine dipstick - with flexible tube - early Chevy small block	50.95
GS4005	Engine dipstick - with flexible tube - late Chevy small block	50.95
GS4006	Engine dipstick - with flexible tube - Chevy big block	50.95



Some Tips For a Successful Ididit Column Installation.....

1. Before you start, the seat you will be using or a good facsimile MUST be in place. That means no milk crates or lawn chairs are acceptable. The steering wheel position and the pedal position all relate to the comfort of the driver. Getting them right can be the difference between pleasure and pain behind the wheel.
2. Equally as important is the location of the engine, cylinder head, and headers. These components, or good mock-ups, should be in place to assure you have proper clearance for your steering linkages.
3. The position of the transmission linkage is also important. IF you do not have clearance for a solid rod style linkage and a cable shift linkage is necessary, be sure to leave yourself two inches of space between the columns lower shift linkage and the firewall.
4. Center your column on the driver's seat. Offsets and angled columns are awkward and uncomfortable.
5. Position the column/steering wheel so your arms are relaxed and comfortable when the seat is adjusted.
6. Locate column for maximum use of the tilt mechanism. It does no good to have the wheel tilted into the dash or down on the seat.
7. Column drops should be made to fit both the bottom of the dash and the column snugly and in a stable fashion. No wobbles or vibration should be expected.
8. Lower mounts should be stable and adjustable to fit the angle of the floor or firewall where the column passes through (or a fixed custom made mount fabricated). This mount MUST also be sealed tight from exhaust fumes, heat, dirt, and water.
9. If you have a floor mounted brake and/or clutch pedal assembly, make sure you have clearance for the column.
10. Use up to three U-joints and joint supports as needed to keep the linkage operation smooth, strong, stable and safe.
11. **Ididit, Inc.** recommends using splined or DD shafting instead of welded or pinned shafting for safety reasons.

As silly as it may sound, they have found that using an aluminum pie tin and a length of wooden dowel is an excellent way to determine column position and length. Use about 4 feet of dowel. Add between 1-1/2 inches and 3 inches beyond the firewall/floor if using a steering box. If you are using a rack, you can go as far as 5 inches into the engine compartment. Watch for clearance.

Simply tack the tin to the dowel (as seen in steering wheel to column), and have one person hold them in position while seated in the driver's seat. A second person can then measure and mark such essential dimensions as how long the column should be from the steering wheel to the firewall/floor, the distance between the center of the column and the bottom of the dash, the point where the column will pass into the engine compartment, and the center-line of the driver's body/seat.

Sometimes the simplest way is also the best.

Measuring Suggestions:

For Steering Columns:

Ididit, Inc. measures a steering column from the top of the column - the top edge of the column housing - down to the bottom of the output shaft on all columns EXCEPT tilt/telescoping columns.

Tilt/telescoping columns are measured from the top edge of the column adapter down to the end of the output shaft when the column is in fully collapsed position. The steering wheel will take up approx. 1-1/2" above the adapter. In the following pages, the standard measurements are shown for each type of column. Use these drawings to determine the critical measurements according to your specific applications.

For Column Drops:

Ididit, Inc., measures column drops from the mounting surface on the bottom of the dash to the center-line of the steering column.

Please remember that we can only supply you with the correct column and accessories if you take the time to make careful measurements. These are guidelines for you to determine what you need, but because your project is unique, you are responsible for locating each component. Call if you have additional questions. We are here to help you!

How to Measure a Steering Column

STEP 1 Steering Wheel and Adaptor

Most aftermarket steering wheels will need 4" from the gripping surface of the wheel to the top of the outer housing of the steering column. Measure and mark the dowel. This is where the measurement of your steering column should start.

STEP 3 Lower Cone

This part of the column is customizable. Standard length is 3.3", it can be shortened to 1.5" upon request (normal custom charges apply). Measure 3.3" (or custom length if it applies) from the bottom of the sleeve or shift hub and mark the dowel.

STEP 5 Tube

The tube can be made to any length longer than 4.7". The tube can protrude through the floor as long as you would like or can stop inside the vehicle like our "shorty" column. In standard applications the tube should protrude through the floor 1"-3". On column shift versions the lower shift linkage will attach to the end of the tube. Mark on the dowel where the firewall will meet the tube.

STEP 2 Upper sleeve and shift hub

These two pieces can not change in size. Measure 4" (floor shift) or 6 1/4" (column shift) from the top of the column and mark the dowel.

Add 1/4" to represent the gap between the sleeve and the cone.

STEP 4 Wire slot position

The position of the wire slot is important because it will determine where your under dash mount will attach to the column. The standard is 4" below the cup at 12 o'clock.. This can be customized. The maximum is 10" below the cup on a floor shift and 7.75" on a column shift. Be sure to tell us what position on a clock face you would like it to be. Measure 4" (or custom length if it applies) from the bottom of the cone and mark the dowel.

STEP 6 Shaft

The shaft can be made to any length between 1.5"-8" from the bottom of the tube. The shaft can be 1" 48, 1" DD, 3/4" 36, or 3/4" DD (custom charges may apply). Measure 1.5" (or custom length if it applies) from the end of the tube. Mark on the dowel where the shaft will end.

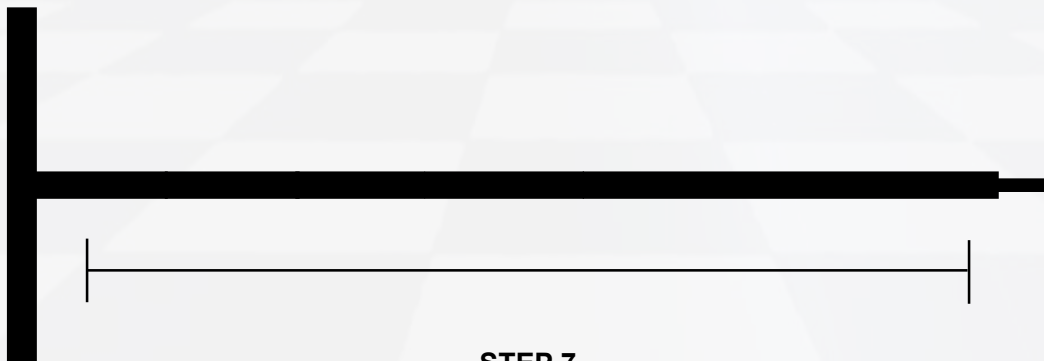
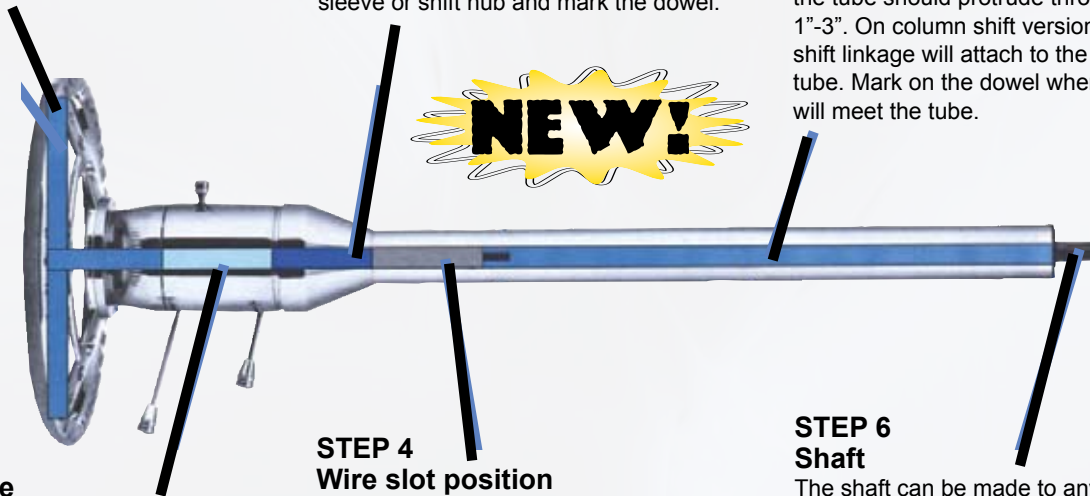

STEP 7

Calculate the numbers

On the dowel measure from the top outer housing (Step 1) to the end of the output shaft (Step 7). Be sure to note any custom dimensions for step 3-6.



NON-TILT COLUMNS



SPECIFICATIONS	
Tube Diameter	Steel - 2 • Aluminum 1 3/4"
Output Shaft	Steel - 1" DD • Aluminum 1" 48
Available Finishes	Paintable Steel • Chrome-plated Steel Brushed Aluminum • Polished Aluminum
Steering Wheel Adapter Required	69 or newer GM pass car

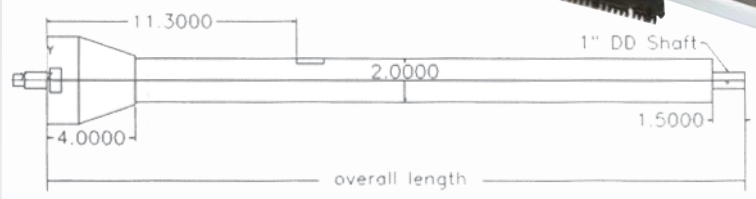

STEEL OR CHROME NON-TILT COLUMNS

This simple but handsome column is similar but much cleaner in appearance than factory columns. The length of the column head makes this column very small, yet completely functional. By requiring less space than the tilt version this column can be put into the smallest of driving compartments. Living up to the saying good things come in small packages.

NON-TILT STEEL OR CHROME COLUMN

	Paintable Steel	Price	Chrome	Price
12" Non-Tilt Col	1010120010	261.00	1010120020	372.00
16" Non-Tilt Col	1010160010	261.00	1010160020	372.00
28" Non-Tilt Col	1010280010	261.00	1010280020	372.00
30" Non-Tilt Col	1010300010	261.00	1010300020	372.00
32" Non-Tilt Col	1010320010	261.00	1010320020	372.00
35" Non-Tilt Col	1010350010	261.00	1010350020	372.00

ALUMINUM NON-TILT COLUMNS

If aluminum is what you're after, then these are the answer for you. Aluminum non-tilt columns offer the same space saving features as the steel or chrome version. The aluminum columns are available in brushed or polished finish. The brushed column is clear anodized making it nearly maintenance free. No matter which column you prefer, nothing matches the elegance of aluminum.

NON-TILT ALUMINUM COLUMNS

	Brushed Aluminum	Price	Polished Aluminum	Price
12" Non-Tilt Col	1020120030	473.00	1020120040	473.00
16" Non-Tilt Col	1020160030	473.00	1020160040	473.00
28" Non-Tilt Col	1020280030	473.00	1020280040	473.00
30" Non-Tilt Col	1020300030	473.00	1020300040	473.00
32" Non-Tilt Col	1020320030	473.00	1020320040	473.00
35" Non-Tilt Col	1020350030	473.00	1020350040	473.00

NON-TILT COLUMN SHIFT

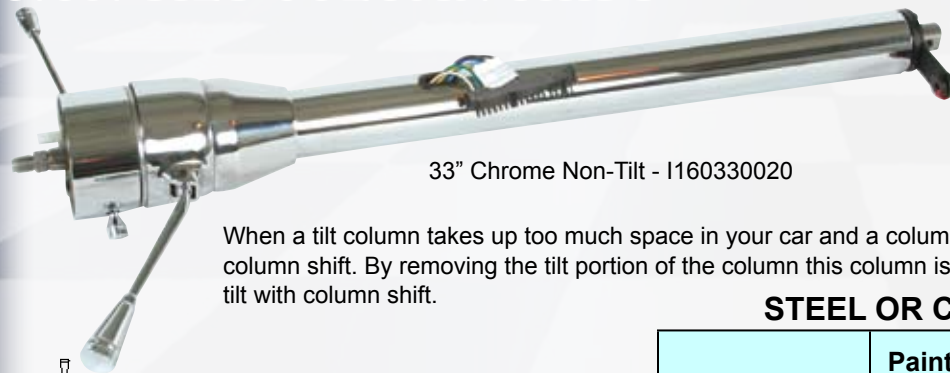

33" Chrome Non-Tilt - I160330020

SPECIFICATIONS	
Tube Diameter	2-1/4"
Output Shaft	1" DD
Available Finishes	Paintable Steel Chrome-plated Steel
Steering Wheel Adapter Required	69 or newer GM pass car

When a tilt column takes up too much space in your car and a column shift is a must, try this straight column shift. By removing the tilt portion of the column this column is a full 2" shorter than a standard tilt with column shift.

STEEL OR CHROME COLUMN SHIFT

	Paintable Steel	Price	Chrome	Price
18" Non-Tilt Col	I160180010	444.00	I160180020	584.00
28" Non-Tilt Col	I160280010	444.00	I160280020	584.00
30" Non-Tilt Col	I160300010	444.00	I160300020	584.00
33" Non-Tilt Col	I160330010	444.00	I160330020	584.00
35" Non-Tilt Col	I160350010	444.00	I160350020	584.00

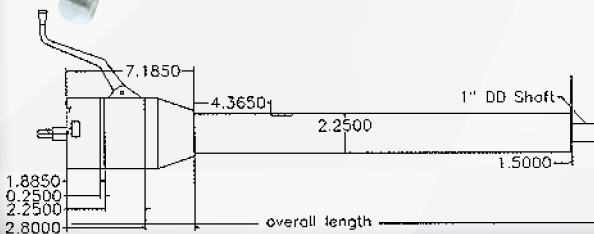



STEEL OR CHROME TILT COLUMNS



32" Chrome Tilt Column - I120320020

SPECIFICATIONS

Tube Diameter	2"
Output Shaft	1" DD
Available Finishes	Paintable Steel Chrome-plated Steel
Steering Wheel Adapter Required	69 or newer GM pass. Car

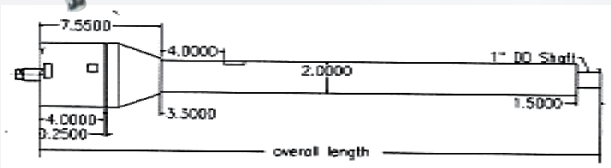

STEEL OR CHROME TILT COLUMNS

	Paintable Steel	Price	Chrome	Price
12" Tilt Col	I120120010	333.00	I120120020	443.00
16" Tilt Col	I120160010	333.00	I120160020	443.00
28" Tilt Col	I120280010	333.00	I120280020	443.00
30" Tilt Col	I120300010	333.00	I120300020	443.00
32" Tilt Col	I120320010	333.00	I120320020	443.00
35" Tilt Col	I120350010	333.00	I120350020	443.00

STEEL TILT COLUMN

This column has become an industry standard. While it is not the most expensive column, it is by far the most popular. The steel tilt column offers the added comfort of tilt as well as self-cancelling turn signals, four-way flashers, and standard dress-up kit. For extra eye appeal, you can order your steel tilt column in a chrome-plated finish.

STEEL OR CHROME TILT COLUMN WITH IGNITION

	Paintable Steel	Price	Chrome	Price
12" Tilt	1520120010	472.00	1520120020	583.00
16" Tilt	1520160010	472.00	1520160020	583.00
28" Tilt	1520280010	472.00	1520280020	583.00
30" Tilt	1520300010	472.00	1520300020	583.00
32" Tilt	1520320010	472.00	1520320020	583.00
35" Tilt	1520350010	472.00	1520350020	583.00

STEEL TILT COLUMN WITH IGNITION SWITCH

Put the convenience of an ignition switch at your fingertips with a tilt column and ignition. Along with the standard tilt column features this column also includes two coded keys and an electric switch. The ignition switch is smaller and is encased in a smooth, sleek housing that is not only pleasing to the eye but concealed enough that you may not even know it's there. The column also includes fuses and relays to carry the high amperage of present day electrical systems.

ALUMINUM TILT COLUMNS



32" Polished Aluminum Tilt - 1030320040

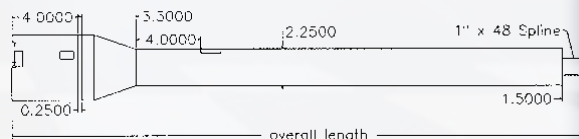

SPECIFICATIONS

Tube Diameter	2-1/4"
Output Shaft	1" 48
Available Finishes	Brushed Aluminum Polished Aluminum
Steering Wheel Adapter Required	69 or newer GM pass car

ALUMINUM TILT STEERING COLUMNS

	Brushed Aluminum	Polished Aluminum	Price
12" Tilt Col	1030120030	1030120040	650.00
16" Tilt Col	1030160030	1030160040	650.00
28" Tilt Col	1030280030	1030280040	650.00
30" Tilt Col	1030300030	1030300040	650.00
32" Tilt Col	1030320030	1030320040	650.00
35" Tilt Col	1030350030	1030350040	650.00

ALUMINUM TILT COLUMNS

If aluminum is what you're after, then these are the answer for you. Aluminum non-tilt columns offer the same space saving features as the steel or chrome version. The aluminum columns are available in brushed or polished finish. The brushed column is clear anodized making it nearly maintenance free. No matter which column you prefer, nothing matches the elegance of aluminum.



STEEL OR CHROME TILT COLUMN - COLUMN SHIFT

SPECIFICATIONS

Tube Diameter	2-1/4"
Output Shaft	1" DD
Available Finishes	Paintable Steel Chrome-plated Steel
Steering Wheel Adapter Required	69 or newer GM pass. Car

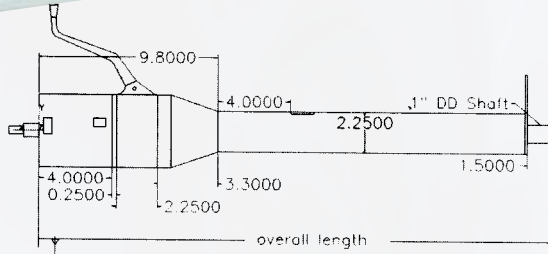

STEEL OR CHROME TILT COLUMN SHIFT

	Paintable Steel	Price	Chrome	Price
18" Tilt Col Shift	1130180010	510.00	1130189910	650.00
28" Tilt Col Shift	1130280020	510.00	1130280020	650.00
30" Tilt Col Shift	1130300010	510.00	1130300020	650.00
32" Tilt Col Shift	1130330010	510.00	1130330020	650.00
35" Tilt Col Shift	1130350010	510.00	1130350020	650.00

STEEL TILT COLUMN SHIFT

This column has become an industry standard. The steel tilt column shift offers the added comfort of tilt as well as self-cancelling turn signals, four-way flashers, and standard dress-up kit. Along with these standard features is the indexable lower shift arm. With 12 possible positions adjustability is just the turn of a wrench away.

TILT COLUMN SHIFT WITH IGNITION SWITCH

Put the convenience of an ignition switch at your fingertips with a tilt column shift with ignition. Along with the standard tilt column features this column also includes two coded keys and an electric switch. The ignition switch is smaller and is encased in a smooth, sleek housing that is not only pleasing to the eye but concealed enough that you may not even know it's there. The column also includes the fuses and relays to carry the high amperage of present day electrical systems.

STEEL OR CHROME TILT COLUMN SHIFT WITH IGNITION

	Paintable Steel	Price	Chrome	Price
18" Tilt Col Shift	1530180010	649.00	1530180020	789.00
28" Tilt Col Shift	1530280010	649.00	1530280020	789.00
30" Tilt Col Shift	1530300010	649.00	1530300020	789.00
32" Tilt Col Shift	1530330010	649.00	1530330020	789.00
35" Tilt Col Shift	1530350010	649.00	1530350020	789.00

ALUMINUM TILT COLUMN SHIFT

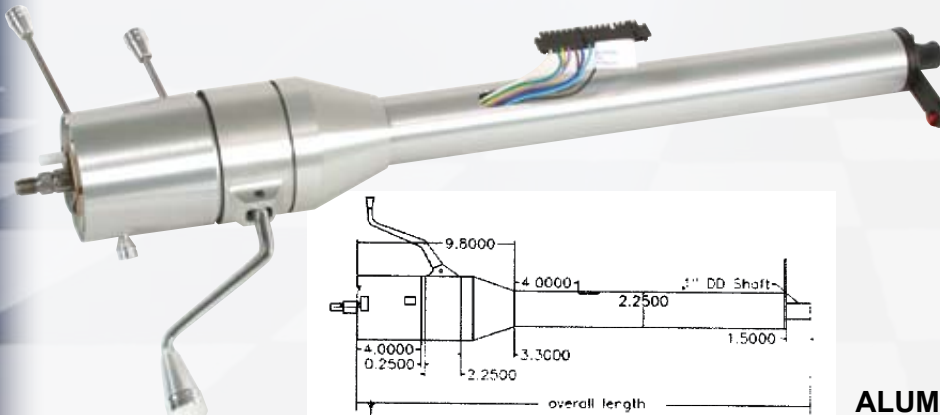

SPECIFICATIONS

Tube Diameter	2-1/4"
Output Shaft	1" 48
Available Finishes	Brushed Aluminum Polished Aluminum
Steering Wheel Adapter Required	69 or newer GM pass car

ALUMINUM TILT COLUMNS

If aluminum is what you're after, then these are the answer for you. Aluminum non-tilt columns offer the same space saving features as the steel or chrome version. The aluminum columns are available in brushed or polished finish. The brushed column is clear anodized making it nearly maintenance free. No matter which column you prefer, nothing matches the elegance of aluminum.

Ignition switch is not available in aluminum columns

ALUMINUM TILT COLUMN SHIFT

	Brushed Aluminum	Polished Aluminum	Price
18" Tilt Col Shift	1050180030	1050180040	965.00
28" Tilt Col Shift	1050280030	1050280040	965.00
30" Tilt Col Shift	1050300030	1050300040	965.00
33" Tilt Col Shift	1050330030	1050330040	965.00
35" Tilt Col Shift	1050350030	1050350040	965.00



Tilt Floor Shift Steering Column



Tilt Column Shift Steering Column

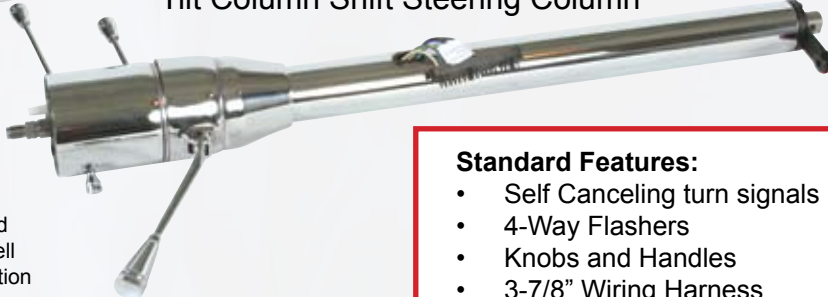

Add the convenience and reliability of a new column built specific for your Pickup. This steering column is not a universal column that requires modification of your original vehicle to install. Simply remove your old column, saving your original under-dash mount as well as the original floor mount. Using one of their installation kits (listed below), install your steering column in place of the old. Add an aftermarket wheel and the gripping surface of the new wheel will be in the same location as the original. Each column is backed by a limited lifetime warranty and is available in many different finishes.

Standard Features:

- Self Canceling turn signals
- 4-Way Flashers
- Knobs and Handles
- 3-7/8" Wiring Harness
- 3/4" - 36" Shaft for all years

With the same specs as the tilt floor version (shown above), the column shift column is just as easy to install. The column has been modified to put your aftermarket wheel in the same location as the original. The column comes complete with a neutral safety switch, however an indicator is not included. The shift pattern on the column will allow you to use either a 3-speed or 4-speed transmission (except early power glide because they have a reverse pattern transmission). A shift linkage is required for installation and will attach to the lower shift linkage provided on the column.

TILT FLOOR SHIFT STEERING COLUMNS				
	Paintable Steel \$340.00	Chrome Plated \$440.00	Brushed Aluminum \$650.00	Polished Aluminum \$650.00
1960-66 Chevy Truck	1120650010	1120650020	1070650030	1070650040
1967-72 Chevy Truck	1120657010	1120657020	1070657030	1070657040

TILT COLUMN SHIFT STEERING COLUMNS				
	Paintable Steel \$549.00	Chrome Plated \$699.00	Brushed Aluminum \$999.00	Polished Aluminum \$999.00
1960-66 Chevy Truck	1140650010	1140650020	1150650030	1150650040
1967-72 Chevy Truck	1140657010	1140657020	1150657030	1150657040

INSTALLATION KITS - All kits include the necessary components for installation

Deluxe Kits - Everything necessary to install your column with new parts from the column to the gearbox. All you need to know is the diameter of the gearbox input shaft and the number of splines.

Econo Kits - The Econo kit is designed for the builder on a budget. The original rag joint and intermediate shaft are used. In the 1960-66 model, the shaft will need to be cut and modified to match the 3/4" DD coupler. In the 1967-72, the original u-joint can be used with the ididit column. Remember the original rag joint is nearly 40 years old, so be sure to double check that it's in good condition.

Original Harness - Installation kits for vehicles with a factory original harness will include a 4-way flasher kit. This 4-way flasher kit will add the convenience of a 4-way flasher as well as convert your original wiring harness to the 3-7/8" harness found on your ididit column.

Aftermarket Harness - Many aftermarket wiring companies offer replacement panels that incorporate a 4-way flasher unit as well as the flat 3-7/8" harness. If you are using one of these panels a 4-way flasher kit is not necessary as it has been incorporated into the panel.

Tilt & Column Shift Installation Kits							
Kit Type	Deluxe Kit Original Harness		Deluxe Kit Aftermarket Harness			Econo Kit Original Harness	Econo Kit Aftermarket Harness
Contents	Coupler/Shaft/Reg Joint/4-Way Kit		Coupler/Shaft/Rag Joint ** U-joint/Shaft/Rag Joint			Coupler / 4-way Kit	Coupler Only
Gearbox input shaft	Manual 3/4" - 30	Manual 3/4" - 36	Manual 3/4" 30	Manual 3/4" 36	Power 13/16" 36	----	---
1960-62	3006001001	3006002001	3006001000	3006002000	-N/A-	3001001001	3000313449
1963-66	3006001002	3006002002	3006001000	3006002000	-N/A-	3001001002	3000313449
1967-72**	-N/A-	-N/A-	3007001000	3007002000	3007003000	-N/A-	-N/A-
	\$190.00	\$190.00	\$155.00	\$155.00	\$190.00	\$75.00	\$38.00



Ididit offers these add-ons for use in your steering column. While any of these items can be added to your column it is much easier while the column is being assembled. Labor charges apply. Ask your sales representative about adding any of these items.



CRUISE CONTROLS

For non-computer engines:

This Rostra electric servo unit uses solid state electronics for accuracy and reliability. Servo and control units are small enough to fit under any dash. Kit includes pulse generator and your choice of control handle.

Cruise Control Kit - Non-Computerized Engine
3100020000 each275.00

For computerized engines:

This Rostra unit gathers information from your car's computer, so no external sensors are required. Adjustable for 2000, 4000, or 8000 pulses per mile. Small enough to fit under any dash. Kit includes your choice of control handle.

Cruise Control Kit - Computerized Engine
3100010000 each220.00



CRUISE COVER

Dress-up your cruise control handle with this aluminum cover. Available in brushed or polished.

Aluminum Cruise Control Cover Brushed
2501000030 each24.95
Aluminum Cruise Control Cover Polished
2501000040 each24.95



CHROME SHIFT INDICATOR HOUSING

Add some flash with this chrome indicator housing. The housing installs easily with two screws and can be added over an existing Ididit acrylic indicator or purchased together as a kit.

Indicator/Housing - 3 Speed
260020002084.95
Indicator/Housing - 4 Speed
260025002084.95
Housing with pointer
260030002064.95
Housing only
260035002037.50
Pointer
260040002027.50

DIMMER OR WIPER KITS

The Tilt or turn lever is replaced with this Ron Francis' Wireworks unit. Puts the convenience of dimmer or wiper control at your fingertips.

Dimmer Kit - Turn Signal Lever
3100030000 each95.00

Dimmer Kit - Tilt Lever
3100040000 each89.00

Wiper switch is on/off only. Two or three speed wipers cannot be controlled with this kit.

Wiper Kit - Turn Signal Lever
3100050000 each95.00

Wiper Kit - Tilt Lever
3100060000 each89.00



SHIFT INDICATOR

Simplicity itself! This simple to install indicator is precision crafted from high quality acrylic and made to fit any 4" diameter column. It can be positioned anywhere on the column head for easy reading.

Indicator with pointer - Acrylic 3 Speed
2600000010 each20.00

Indicator with pointer - Acrylic 4 Speed
2600050010 each20.00

Indicator - Acrylic 3 Speed
2600100010 each15.00

Indicator - Acrylic 4 Speed
2600150010 each15.00

Pointer - Acrylic
2600450010 each7.50



FEMALE END PLUG

This is it, the female plug kit that matches the male plug on your ididit column. This kit includes eight crimp-on clips that can be easily attached to your wires and then clipped into the harness. All you need to do is match the wires by function rather than color.
3106050010 each12.00

SHOW OFF YOUR TRUCK!



COLUMN DROPS



Measurements are from the bolting surface under the dash to the center line of the column.



	GM 2 3/8" Hole		Van - 2" Hole		Ididit - 2 1/4" Hole		Ididit II- 2" Hole		Ididit 1 3/4" Hole	
Length	Brushed	Polished	Brushed	Polished	Brushed	Polished	Brushed	Polished	Brushed	Polished
2-1/2"	2302170030	2302170040	2302270030	2302270040	2302370030	2302370040	2302470030	2302470040	2302570030	2302570040
3-1/2"	2303170030	2303170040	2303270030	2303270040	2303370030	2303370040	2303470030	2303470040	2303570030	2303570040
4-1/2"	2304170030	2304170040	2304270030	2304270040	2304370030	2304370040	2304470030	2304470040	2304570030	2304570040
5-1/2"	2305170030	2305170040	2305270030	2305270040	2305370030	2305370040	2305470030	2305470040	2305570030	2305570040
6-1/2"	2306170030	2306170040	2306270030	2306270040	2306370030	2306370040	2306470030	2306470040	2306570030	2306570040
7-1/2"	2307170030	2307170040	2307270030	2307270040	2307370030	2307370040	2307470030	2307470040	2307570030	2307570040

ALL COLUMN DROPS LISTED ABOVE ARE \$59.95 each



STEEL WELD ON COLUMN DROP		
2" Hole Only		Price
3"	2303490010	30.00
4"	2304490010	30.00
5"	2305490010	30.00
7"	2307490010	30.00



GM 1969 OR NEWER UNDER DASH MOUNT			
	Brushed	Polished	Price
2" Hole	2310000030	2310000040	65.00
2-1/4" Hole	2310500030	2310500040	65.00

FLOOR MOUNTS

BRACE YOUR STEERING COLUMN IN STYLE

Available in three diameters 1-3/4", 2", 2-1/4" to fit your aftermarket column. This swivel ball style polished floor mount even has a cover plate for the engine compartment side. Includes all the needed hardware for installation. Please specify if you are using a chrome column.



- 1-3/4" Polished Aluminum Swivel Ball Floor Mount
24005000040.....89.95
- 2" Polished Aluminum Swivel Ball Floor Mount
24015000040.....89.95
- 2-1/4" Polished Aluminum Swivel Ball Floor Mount
24025000040.....89.95

THE FOLLOWING ARE FOR CHROME PLATED COLUMNS

- 1-3/4" Polished Aluminum Swivel Ball Floor Mount
24005500040.....89.95
- 2" Polished Aluminum Swivel Ball Floor Mount
24015500040.....89.95
- 2-1/4" Polished Aluminum Swivel Ball Floor Mount
24025500040.....89.95



This functional and inexpensive lower mount will make things secure at the floorboard or firewall. It is available to fit either 1-3/4", 2" and 2-1/4" dia. columns.

- 1-3/4" Adjustable Floor Mount
2400300010.....22.00
- 2" Adjustable Floor Mount
2401300010.....22.00
- 2 1/4" Adjustable Floor Mount
2402300010.....22.00



CABLE SHIFT LINKAGE



ADJUSTABLE FLOOR MOUNT TRIM KIT

The complete kit offers security and handsome appearance as well. The kit includes an adjustable mount, a vinyl boot in black, bone, grey or brown and a polished aluminum trim ring with hardware.

- 1 3/4" Adjustable Trim Floor Mount
2400800010.....37.00
- 2" Adjustable Trim Kit Floor Mount
2401800010.....37.00
- 2 1/4" Adjustable Trim Kit Floor Mount
2402800010.....37.00
- Black Boot
240581001037.00
- Bone Boot
2405820010.....37.00
- Brown Boot
2405830010.....37.00
- Grey Boot
2405840010.....37.00



Ididit Column



Each Cable Shift Linkage Kit contains:

- Shift Cable
- Cable Bracket
- Transmission Bracket

Specify Which type of transmission you have !	2" ididit Column	2-1/4" ididit Column	2" GM/Chrysler OEM Column
GM Transmission	2801000010	2802000010	2801050010
727 & 904 Transmission	N/A	N/A	2801750010

\$110.00 \$110.00 \$135.00

STEERING WHEEL ADAPTORS

These are simply made to adapt the 3, 5, 6, or 9-bolt pattern to the tapered, splined top shaft of a steering column. All Ididit adaptors will fit most Ididit columns as well as most 1969 or newer GM passenger car columns. The adaptor is secured to the top of the column with a single nut.

SHORT 9-BOLT ADAPTORS

The short 9-bolt is unique. It moves the bolting surface of a steering wheel 2" closer to the dash than a standard wheel. Caution should be taken when using this adaptor. Note the clearance required between the wheel and the turn signal lever and/or shift arm. Modifications may be necessary for proper installation.



9-BOLT ADAPTORS

The 9-bolt pattern adaptors will match Lecarra, Billet Specialties, Budnik, Boyd, Grant and many other aftermarket wheels.



5 & 6 BOLT ADAPTORS

Grant & Lecarra version of this adaptor will come with a horn button, Momo, Dino, Nardi, Diablo and Corvette wheels do not.



3-BOLT ADAPTORS

Grant and Wheel Shopped are the most popular applications for the standard three-bolt, while the "Bell" style adaptor adds the convenience of a horn button to a Mullins or Pete & Jake wheel.



STEERING WHEEL ADAPTORS

	Brushed	Price	Polished	Price	Chrome	Price
9-bolt Standard - No Horn	2201300030	55.50	2201300040	55.50	2201300020	88.83
A - 9-bolt Standard	2201310030	49.95	2201310040	49.95	2201310020	99.94
B - 9-bolt Short	N/A	N/A	2201100040	99.00	2201100020	129.00
C - 5-bolt	2207310030	59.95	2207310040	59.95	2207310020	89.95
D - 6-bolt Lecarra	2202310030	59.95	2202310040	59.95	2202310020	89.95
D - 6-bolt Momo	2202320030	59.95	2202320040	59.95	2202320020	89.95
D - 6-bolt Dino/Diablo	2202330030	59.95	2202330040	59.95	2202330020	89.95
D - 6-bolt Nardi	2202340030	59.95	2202340040	59.95	2202340020	89.95
D - 1963-66 Corvette	2202350030	59.95	2202350040	59.95	2202350020	89.95
E - 3-bolt	2208310030	59.95	2208310040	59.95	2208310020	89.95
F - 3-bolt "Bell"	2209310030	80.00	2209310040	80.00	2209310020	110.00

SEE OUR BORGESON SECTION FOR U-JOINTS AND VIBRATION REDUCERS



1928-59 PICKUP DISC BRAKE KITS



Master Power Disc Brake kits bolt to your stock Chevy spindles without modification. All kits provide perfect caliper alignment for even pad wear and support. The calipers are designed by GM (not by the mounting bolts as some other kits do). MPB kits are complete with everything you need and ready to bolt on with common hand tools.

Kits Include the following: Caliper brackets • New Calipers • Rotors • Bearings/Seals • Dust Caps • Pads • Hardware Hoses/Hose Brackets • Bearing Adapters where required. **Bolt circle is 5 x 4 3/4 GM**

NOTE: Disc Brakes require the use of 15" Wheels for these kits

Years	Description	Part #	Price
1928-40	Disc brake kit, bottom	DB1751B	395.00
1941-54	Disc brake kit, bottom	DB1752B	395.00
1955-59	Disc brake kit, bottom	DB1753B	395.00

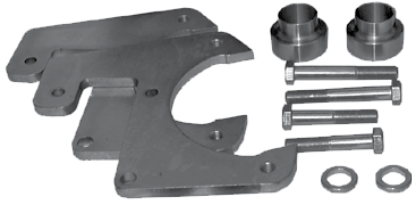

DISC BRAKE BRACKET SET

If you want to obtain your own components and add disc brakes to your truck this caliper bracket kit is what you will need. Each kit includes brackets, hardware and bearing adaptors when required. You supply the rest.

- 1928-40 Pickup**
BR1751K189.95
- 1941-54 Pickup**
BR1752K179.95
- 1955-59 Pickup**
BR1753K189.95



DUAL RESERVOIR MASTER CYLINDER CONVERSION KITS

The bracket and rod kit will bolt to the original location and allow you to add a safe dual piston master cylinder to your truck. You will use the original pedal. Automatic transmissions only.



BRACKET AND ROD KIT

- 1947-54 Pickup - BR1765K129.95
- 1955-59 Pickup - BR1766K119.95

DUAL MASTER CYLINDER

- MC390360M89.95

REMOTE FILL MASTER

- MC1001MZ139.95



UNIVERSAL HANGING PEDAL

This universal firewall mounted hanging pedal works great on any truck with a straight firewall. The kit comes with an 8" dual diaphragm booster and an extra stroke master cylinder for a great pedal feel.

- PA1200K399.95

POWER BRAKE CONVERSION KITS

Add power brakes to your early Chevy truck with one of the bolt on under floor kits.

Kits include mounting brackets, 7" power booster and linkage to the original pedal which you re-use. '47-54 works only with automatic transmissions.

1947-54 Pickup (automatic only)

- BM1751 kit395.00

1955-59 Pickup

- BM1752 kit395.00



1960-70 PICKUP DISC BRAKE KITS



1963-70 SHOWN

POWER DISC BRAKE KITS

You just can't enjoy driving your truck without reliable disc brakes. These kits include the parts necessary to perform a disc brake conversion. You'll just have to supply a few pieces of hard brake line to tie the system in from the supplied combination valve to the rest of your system. These kits are available in stock height or 2 1/2" dropped spindle configuration, with or without power booster and in a 5 or 6 lug pattern. 1/2 Ton Pickups ONLY.

Each kits includes: Booster • Master Cylinder • Combination Valve Kit • Spindles • Caliper Brackets • Calipers • Pads • Rotors • Bearings Seals and Hoses. NOTE: Use of stock wheels requires backspace of at least 4 1/2".

Year	Bolt Pattern	Description	Part #	Price
1960-62	5 lug	Power disc kit - stock height	DB1754P	1195.00
1960-62	5 lug	Manual disc kit - stock height	DB1754M	1095.00
1960-62	6 lug	Power disc kit - stock height	DB1754P6	1295.00
1960-62	6 lug	Manual disc kit - stock height	DB1754M6	1195.00
1960-62	5 lug	Power disc kit - 2 1/2" dropped spindles	DB1754PD	1195.00
1960-62	5 lug	Manual disc kit - 2 1/2" dropped spindles	DB1754MD	1095.00
1960-62	6 lug	Power disc kit - 2 1/2" dropped spindles	DB1754PD6	1295.00
1960-62	6 lug	Manual disc kit - 2 1/2" dropped spindles	DB1754MD6	1195.00
1963-70	5 lug	Power disc kit - stock height	DB1755P	1195.00
1963-70	5 lug	Manual disc kit - stock height	DB1755M	995.00
1963-70	5 lug	Manual disc kit - stock height	DB1755MD	1095.00
1963-70	5 lug	Power disc kit - 1 1/2" drop	DB1755PD	1195.00
1963-70	6 lug	Power disc kit - stock height	DB1755P6	1295.00
1963-70	6 lug	Manual disc kit - stock height	DB1755M6	1095.00
1963-70	6 lug	Power disc kit - 2 1/2" dropped spindles	DB1755PD6	1295.00
1963-70	6 lug	Manual disc kit - 2 1/2" dropped spindles	DB1755MD6	1095.00



POWER BRAKE CONVERSION

Replace your old power booster or add power brakes with one of our easy bolt on power booster, with a master cylinder. These kits bolt directly to the firewall and come with the correct linkage.

1960-62 Pickup (auto trans)

BM1753 295.00

1960-62 Pickup (hydraulic clutch)

BM1750 495.00

1963-72 Pickup

BM1754 295.00

DROPPED SPINDLES

These high quality forgings will lower your truck 2 1/2" the right way to give you that pro-street look. Maximum 3 1/2" wheel offset is required to use these spindles.



1960-62 Pickup

SP1754D pair 395.00

1963-70 Pickup

SP1755D pair 395.00

1971-87 Pickup

DP1757D pair 395.00

Valves

The **valving** in a disc brake system is needed to supply the correct front to rear balance. There are three types of valves used in a braking system:



1 Metering

A metering valve is needed in the front disc portion of a disc / drum system to allow the rear drums to contribute to the braking. The rear drums are slower reacting than the front discs. The metering valve retards the application of the front disc brakes slightly allowing the rears to catch up. Without a metering valve the car will "nose dive" and you will experience excessive front pad wear.

Metering valve to prevent excessive front braking and allow the rear drums to contribute to the braking.



VL3526 each \$89.95

2 Proportioning

A proportioning valve modulates the pressure to the rear drum brakes. The modulation is necessary to minimize rear wheel lock up found in heavy braking and to compensate for the difference in braking conditions in front disc rear drum systems. As pressure is applied to the system, full pressure is allowed to the rear drums up to a certain point. Beyond that point pressure to the rear is reduced preventing rear wheel lock up.

Adjustable proportioning valve to provide extra adjustment to the rear drums.



VL3350W each 89.95

An adjustable proportioning valve is used when you have a special rear condition that requires higher or lower pressure than normal conditions. You should always use a metering valve to the front when using the adjustable valve to the rear.

Provides the correct front to rear pressure balance and eliminates rear wheel lockup and nose dive.

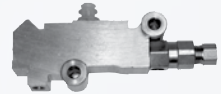

Disc / drum combination valve
VL3350 each 99.95

Disc / disc combination valve
VL3359 each 109.95

3 Residual

There are two types of residual valves used in a braking system. A ten pound residual valve will maintain a line pressure to keep the rear drum brake shoes out close to the drums giving a higher firmer pedal. Without this 10 lb residual valve to the rear you will experience a spongy pedal. A two pound residual valve is required whenever the master cylinder is lower than the calipers to prevent backflow of fluid from the calipers to the master. These two pound valves are typically used when the master cylinder is mounted under the floor in a street rod application.

10 lb residual valve used in the drum brakes to keep the shoes out close to the drums eliminating a spongy pedal.



VL3710K each 26.00

2 lb residual valve used to prevent fluid backflow from the calipers to the master cylinder in under floor applications eliminating spongy pedal.

VL3702K each 26.00

Helpful tools



MASTER CYLINDER BLEEDER KIT
Always bleed the master cylinder before installation on the vehicle. Fittings screw into the master cylinder ports and the piston is worked in and out to remove the air.

AC2002 Bleeder kit 3.95



PLUMBING SURVIVAL KIT
This handy plumbing kit contains miscellaneous fittings to help plumb up your braking system. Also included are the solid plugs needed to perform master cylinder diagnostics.

AC2000 Plumbing kit 29.95



POWER BOOSTER PUSH ROD GAUGE
Use this tool to correctly set the length of your power booster push rod. Set the depth of the master piston hole, flip the tool and check the length of the booster pin. Using this tool can save you hours of frustrating work!

AC2003 each 19.95



BALL MILLED BREATHERS

Slotted top - push in type.
SPC8498 24.00



MOON NO NAME SMALL BLOCK CHEVY VALVE COVERS

Cast aluminum, finned and highly polished. Comes with studs, nuts and gaskets. Covers are machined for two 1 1/4" breathers and come with a filler cap.
1984 and up
MP659 pair 285.00



MOON NO NAME SMALL BLOCK CHEVY VALVE COVERS

Cast aluminum. Finned and highly polished. 1957-84 - no holes
MP649 each..... 215.00



BIG BLOCK CHEVY VALVE COVERS

Finned, polished cast aluminum. No-name valve covers for the Big Block Chevy's. Shown are with High Rise Breathers.
MP657 pair 275.00



1957-84 /SMALL BLOCK CHEVY PCV & FILL VALVE COVERS

Now you can use the famous finned No Name valve covers on your 1957-84 Chevy. Complete with oil filled holes with billet cap, PCV and breather holes.
M649PCV2 each 285.00



348-409 CHEVY VALVE COVERS

Designed specifically for the early model 348 & 409 Chevy engines. Made of finned cast aluminum. Available in polished finish only.
MP650 each 285.00



BARE FOOT GAS PEDAL

Mounts to your existing pedal set up.
Small - 6"
R3034S each 14.50
Large - 7"
R3034L each 18.50
Dimmer switch
R3033 each 7.00



THE MOON 5 GAUGE SET

Kit includes programmable electric speedometer 140 MPH, electric oil pressure, electric water temperature, volt, and fuel level. Comes with all senders including pulse sender for speedometer and fuel sender. Please specify transmission when ordering.
Black
MPG35005 425.00
White
MPG35005WH 425.00

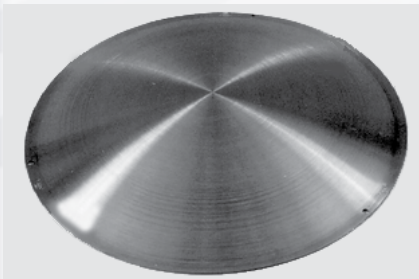

MOON WHEEL DISCS

Metal spun discs .064" thick aluminum contoured to clear spindles and/or axle protrusions. Clear coated for easy maintenance. These are the "screw on style".
(14" dia.) P-5858-14 each 34.95
(15" dia.) P-5858-15 each 34.95
(16" dia.) P-5858-16 each 39.95



ALUMINUM GAUGE PANEL

Easy fit for 2" gauges.
2 holes - fits 2 gauges - 5 5/8" x 3 1/8"
OF4009 each 27.00
3 holes - fits 3 gauges - 8 1/4" x 3 1/8"
OF4008 each 28.00
4 holes - fits 4 gauges - 10 3/4" x 3 1/8"
OF4007 each 32.00

OTHER SIZES AVAILABLE INQUIRE



**1947-55 CHEVROLET & GMC PICKUP
CUSTOM A/C, HEAT AND DEFROST SYSTEM**



Custom rubber grommet fits in factory blower motor hole for heater and A/C lines.



CAP-4000G - Custom In-dash Switching Fits 1947-53 trucks with horizontal slots in speaker grill. Includes center vents & lever style switches behind speaker grill with either in-dash or under dash outside vents.

CUSTOM A/C HEAT AND DEFROST COMBO

(12 Volt electrical system required)

This Heat Cool & Defrost System includes a Deluxe Plenum molded to fit the contour along the bottom of the dash for switches, controls and louvers. Retains original cowl vent and majority of glove box.

Designed for easy installation, the unit mounts directly to the firewall where A/C and Heater lines will pass through the factory blower motor holes with custom rubber grommet. Custom condenser mounting, neat aluminum lines, and step-by-step instruction are included.

Optional in-dash switching and vent package that fits behind speaker grill.

1947-55 with Deluxe Plenum Complete System (Cable Controls)	
CAP-4000D	1,040.00
Complete System (Electronic Controls)	
CAP-4100D	1,110.00

1947-53 Vents & Switches Behind Speaker Grill	
Complete System (Cable Controls)	
CAP-4000G	1,040.00

Optional System Upgrades

- Polished Compressor
- Chrome Drier
- 14" Electric Condenser Fan
- Condenser Fan Wiring Kit
- Defrost Outlet
- Trinary Pressure Switch
- Radiator Fan Shroud
- 16" Electric Fan w/Shroud



Information Required to Order:

- 1. Engine:** Size, Year, Make
- 2. Water Pump Length:** Short or Long (Chevy V8 Engine)
- 3. Compressor Mount:** Driver or Passenger Side
- 4. Refrigerant Choice:** R-12 or 134a

NOTE: Clean firewall version may require modifications to firewall and or kick panel area to complete installation.



**1955-59 CHEVROLET & GMC PICKUP
CUSTOM A/C, HEAT AND DEFROST SYSTEM**



INCLUDES DELUXE LEVER CONTROL
Replica lever control for the Hurricane A/C Heat & Defrost system replaces original heater control to maintain an original appearance.

This system is designed for easy installation with Deluxe Lever Control, Custom Corner Louvers, New Plastic Glove Box, Custom Condenser Mounting, Floor Heat and De-Humidified Defrost. Unit mounts directly to the firewall utilizing stock heater mounting locations. A Clean Firewall Unit is also available along with the Billet Slide Lever A/C and Heater Control, Bulkhead fittings and Billet Vents to add a unique custom touch to your truck. Compressor and alternator brackets available for V-8 and inline straight six cylinder Chevrolet engines.

1955-59 Chevy Pickup
Includes New Dlx Lever Control Complete System
CAP-9000 1,065.00

1955-59 GMC Pickup
Integrates with Factory Lever Style Controls Complete System
CAP-9000G 1,065.00

1955-59 Chevy & GMC Pickup
Underdash Rotary Switches & Controls Complete System
CAP-9000S 1,065.00

Optional System Upgrades

- Polished Compressor
- Chrome Drier
- Kick Panels
- Defrost Outlet
- Water Pump Fan
- Radiator Fan Shroud (fits stock radiator only - will not fit Desert Cooler radiator)

INQUIRE FOR UPGRADE PRICING



Information Required to Order:

1. **Engine:** Size, Year, Make
2. **Water Pump Length:** Short or Long (Chevy V8 Engine)
3. **Compressor Mount:** Driver or Passenger Side
4. **Refrigerant Choice:** R-12 or 134a

NOTE: Clean firewall version may require modifications to firewall and or kick panel area to complete installation. Recommended for trucks in early stages of construction, that have not been painted yet.



DON'T FORGET TO SHOW OFF YOUR TRUCK ONCE YOUR PROJECT IS COMPLETE!



1960-66 CHEVROLET PICKUP CUSTOM A/C, HEAT AND DEFROST SYSTEM

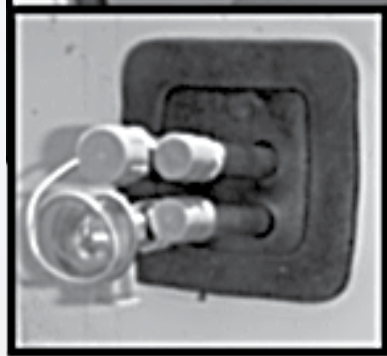
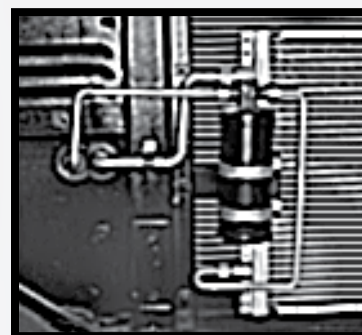
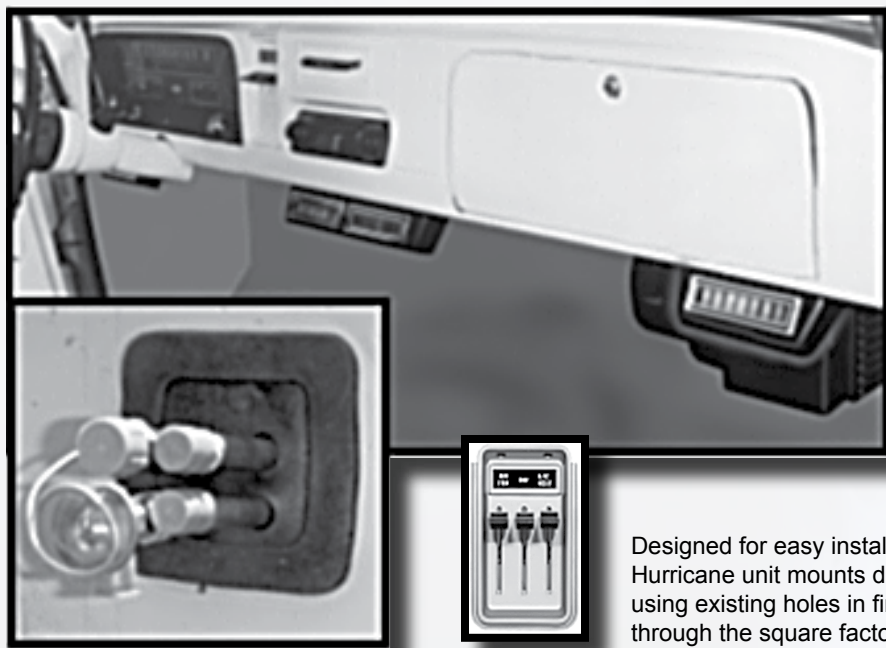

Designed for easy installation using existing factory firewall holes. Hurricane unit mounts directly to firewall with custom mounting plate using existing holes in firewall. A/C and heater lines route neatly through the square factory inlet hole with a custom rubber grommet.

A/C & heater system switching integrates neatly with factory lever style heater control on 1960-66 trucks, for 1964-66 trucks with economy heater (pull/twist heater control knob) a new deluxe lever control is included.

Rectangular louvers mount neatly along the bottom edge of the dash. Condenser assembly includes drier, custom aluminum lines and mounting brackets using factory radiator mounting locations.

- 1960-63 all w/2 lever factory heater control
Complete System CAP-6300S 1,065.00
- 1960-63 w/4 lever factory heater control
Complete System CAP-6300D 1,065.00

- 1964-66 w/Deluxe heater (lever style control) Switching integrates with original heater control
Complete System CAP-6600D 1,065.00
- 1964-66 w/Economy heater (pull/twist knob) Includes Deluxe Lever Heater Control
Complete System CAP-6600S 1,125.00

Optional System Upgrades

- Polished Compressor
- Chrome Drier
- 12" Elec Cond. Fan
- Fan Mounting Kit
- Cond. Fan Wiring Kit
- Water Pump Fan
- 16" Elec. Radiator Fan
- Trinary Switch Upgrade



Information Required to Order:

1. **Engine:** Size, Year, Make
2. **Water Pump Length:** Short or Long (Chevy V8 Engine)
3. **Compressor Mount:** Driver or Passenger Side
4. **Refrigerant Choice:** R-12 or 134a

NOTE: Clean firewall version may require modifications to firewall and or kick panel area to complete installation. Recommended for trucks in early stages of construction, that have not been painted yet.



1967-72 CHEVROLET PICKUP CUSTOM A/C, HEAT AND DEFROST SYSTEM



CAP-7200 Series with Underdash Louvers

Heater Only Cab, w/Heater Control

CAP-7201-U kit 1,065.00

Heater Only Cab, w/AC Control

CAP-7202-U kit 1,065.00



CAP-7200 Series with In-Dash Louvers

Heater Only Cab, w/Heater Control

CAP-7201-I kit 1,065.00

Heater Only Cab, w/AC Control

CAP-7202-I kit 1,065.00



CAP-7200 Series with Factory Style Louvers

Includes adapters for Factory Louvers

Heater Only Cab, w/Heater Control

CAP-7201-F kit 1,065.00

Heater Only Cab, w/AC Control

CAP-7202-F kit 1,065.00

Factory A/C Cab, w/AC Control

CAP-7203-F kit 1,045.00

Factory A/C Cab, w/Heater Control

CAP-7204-F kit 1,045.00

Switching Integrates with factory heater control for both heater and air conditioning functions. Includes your choice of in-dash or under-dash louvers and a new plastic glove box.

Condenser assembly is a replica of the factory original with custom aluminum lines. This condenser features multi-flow design and is available with optional single or dual electric condenser fans to maximize cooling efficiency.

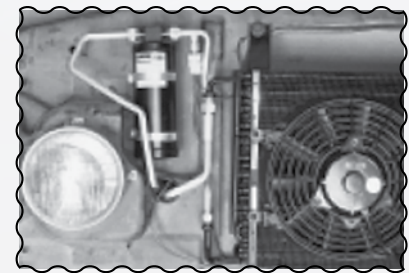

Replica of Factory Condenser
Features Custom Aluminum Lines
and Mounting Brackets for Drier &
Condenser.

Information Required to Order:

1. **Engine:** Size, Year, Make
2. **Water Pump Length:** Short or Long (Chevy V8 Engine)
3. **Compressor Mount:** Driver or Passenger Side
4. **Refrigerant Choice:** R-12 or 134a

NOTE: Clean firewall version may require modifications to firewall and or kick panel area to complete installation. Recommended for trucks in early stages of construction, that have not been painted yet.

**INQUIRE
FOR UPGRADE
PRICING**

Optional System Upgrades

- Polished Compressor
- Chrome Drier
- Dual Condenser Fans
- Single Condenser Fan
- Water Pump Fan

HOW DO YOU CHOOSE THE RIGHT HARNESS FOR YOUR TRUCK ?

If your truck is not among the specific vehicle applications mentioned in this catalog, one of our proven universal kits is your best choice. These kits are designed to be used on a wide range of vehicle types. All of our kits come ready to install. We've thought out the problems for you and designed these kits to be truly Painless. The 12 circuit kits will cover most basic wiring needs.

If your truck will have additional electrical accessories such as power windows, door locks or other creature comforts, you will want our 18 circuit harness. Remember that you may want to install these items some time in the future, so now is the time to provide wiring by installing our 18 circuit harness or by using a modular add-on harness. There is one other consideration that is important: Is your ignition switch on the steering column or in the dash? Use the designated "for GM steering column" for early style "keyed" steering columns from GM. All kits come with more than enough wire and terminals, etc. to do the job. You cut and route to suit your vehicle's needs.

UNIVERSAL CHASSIS HARNESSES



12-CIRCUIT UNIVERSAL GM KEYED STEERING COLUMN
Their 12 circuit kits can be used in just about any vehicle where basic wiring is needed. This kit includes GM (column mounted) ignition switch plugs pre-terminated and ready to install. Also included are pre-wired plugs for headlights and the dimmer switch.
10101 each. 322.00



18-CIRCUIT UNIVERSAL GM KEYED STEERING COLUMN
The 18 Circuit kit allows you to add accessories to the basic wiring such as power windows, door locks, etc. This kit includes GM (column mounted) ignition switch plugs and a GM (column mounted) turn signal switch plug pre-terminated and ready to install. Also included are pre-wired plugs for headlights and the dimmer switch.
10201 each. 365.00



12-CIRCUIT UNIVERSAL
This kit does NOT include the GM column mounted ignition switch plugs but includes the GM column mounted turn signal switch plugs and terminals.
10102 each. 338.00



18-CIRCUIT UNIVERSAL
This kit does NOT include the GM column mounted ignition switch plugs but includes the GM column mounted turn signal switch plugs and terminal.
#10202 each 375.00



GM & Universal Truck Harnesses



12 CIRCUIT GMC/CHEVY TRUCK HARNESS

#10112 - Designed for use on 1963-66 GM/Chevy pickups. This 12-circuit kit includes the following connectors pre-terminated to the harness: Wiper motor, dimmer switch, brake switch, wiper switch, headlight switch, horn, dash light sockets and warning light sockets. Kit also includes alternator pigtail with connector installed. Will work with single or dual dash turn signal indicator.

1963-66 GM/Chevy Pickup
10112 each.....425.00



18-CIRCUIT GMC/CHEVY TRUCK HARNESS

By adding a factory-style bulkhead connector and additional GM connectors we made our universal harness a custom fit for these popular GM/Chevy pickups. Nothing could make re-wiring your truck any easier. For 2X4 & 4X4 trucks. (For 1967-72 GM trucks with factory a/c also use #30901 see below.)

#10206 - 1967-72 Chevy/GMC Trucks 388.00

#10205 - 1973-87 Chevy/GMC Trucks 625.00

A/C HARNESS - CHEVY/GMC

#30901 - For 1967-72 use with chassis harness #10206 with factory air conditioning.

30901 each.....75.00



GM KEYED STEERING COLUMN UNIVERSAL TRUCK HARNESSES

Use in just about any pickup where basic-or-more wiring is needed. Ample wire lengths make this kit especially suited for trucks with long beds and extended cabs. This kit includes GM (column mounted) ignition switch plug and the GM (column mounted) turn signal switch plug pre-terminated and ready to install.

#10103 - 12-Circuit harness kit 445.00

#10203 - 18-Circuit harness kit 470.00



UNIVERSAL TRUCK HARNESSES

Can be used in just about any pickup where basic-or-more wiring is needed. Ample wire lengths make this kit especially suited for everything including trucks with long beds and extended cabs.

#10104 - 12-Circuit harness kit 444.00

#10204 - 18-Circuit harness kit 470.00

COLOR CODED, PREPRINTED WIRE

Wiring a car can sometimes be an intimidating project, but not with a Painless chassis harness. Open the box and the wire is already bundled in sections: front, rear, engine, etc. Simply mount the fuse block, start with one section of the car and route the wire. Each wire is printed with the application so you know right where it goes. To further ensure a painless installation, each chassis harness is color-coded for easy trouble-shooting.





OFF ROAD HARNESS

WEATHERPROOF CHASSIS WIRING HARNESS

The best wiring harness for rough off-road conditions just got better with the introduction of these three new weatherproof harnesses. On top of the already superior Painless design and materials, these tough new kits feature: weatherproof fuse block with clear O-ring-sealed cover, weatherproof heat-sealed crimp-on terminals, waterproof horn relay, machine crimped splices with weatherproof shrink tubing.

Universal - 12-Circuit Weatherproof Chassis Harness
 10140.448.00



FUSE BLOCKS

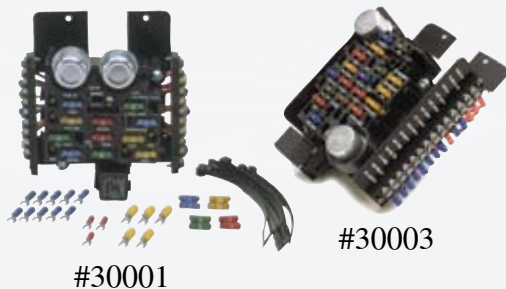

12 & 18 CIRCUIT UNIVERSAL FUSE BLOCKS

Use the 12-circuit OEM style pre-wired fuse block to replace your existing fuse block or as a starting point for custom wiring. All you have to do is terminate your circuit wire and attach it to the fuse block. Pre-wired and labeled for the following circuits: air conditioning/heat, gauges/dash instruments, brake lights, headlights, coil, horn, dome light, radio, electric fan, turn signals, emergency flashers, wipers and alternator. 18-circuit fuse block is the same with additional circuits to wire power windows, door locks, and other optional accessories. Kits include: mounting bracket, fuses, flashers, horn relay, terminal, and full instructions. **Note: No wire with these kits.**

12- Circuit Fuse Blocks
 30001.123.00
 18-Circuit Fuse Blocks
 30003.188.00



PARK NEUTRAL RELAY KIT
 This kit uses the stock neutral safety switch to also provide for ECM park/neutral ground signal needed when installing factory-style fuel injection into older vehicles. For use with any aftermarket shifter or column mounted neutral safety switch.
 60122.50.00

OXYGEN SENSOR FITTING

Weld-in oxygen sensor fitting for all fuel injection systems.
 60406.11.00



700R4 TRANSMISSION TORQUE CONVERTER LOCK-UP KIT

Now you can control the lockup converter on your overdrive transmission with your carbureted engine and not have to buy an expensive computer! With our easy to install Lock-Up Kit you don't need the computer or speed sensor. A vacuum controlled switch and a 4th gear pressure switch/lock up solenoid combination controls the lockup. Comes with everything to complete the job including a pan gasket. Fits any 700R4 GM transmission.
 60109.163.00

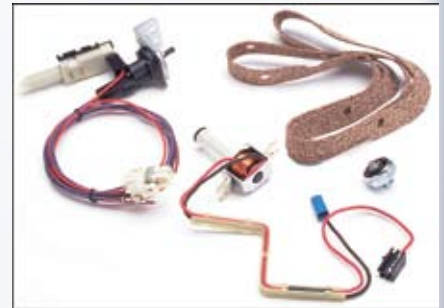

UNIVERSAL FUEL PUMP RELAY KIT
 A relay will prevent voltage drops at the pump thus maintaining constant fuel pump pressure, and will prevent fuel pump amperage overloads from damaging the electrical system. It's a good idea to relay your fuel pump for the street and a must when you're racing.
 50102.37.00



BRAKE LIGHT RELAY KIT
 When upgrading tail lights to the new higher wattage halogens, always use a relay. The Painless kit gives you everything you need to protect your wiring and switches.
 30105.23.00

REMOTE STARTER SOLENOID
 Allows you to position the starter solenoid any place you need to in order to make maintenance easier. Comes with extra wire and connectors to do the job right.
 30203.40.00





HOT SHOT

Designed to overcome starting problems due to an overheated GM style starter or worn out electrical system. Works by boosting amperage to the starter solenoid.

30202.28.00



HOT SHOT PLUS ENGINE BUMP SWITCH

This switch allows you to turn over the engine from the engine compartment for adjusting valves. It also overcomes starting problems due to an overhead starter or worn out electrical system by boosting amperage to the starter solenoid every time the vehicle is started.

30201.57.00

ADJUSTABLE ELECTRIC FAN THERMOSTAT KIT

This kit is designed to allow a wide range of temperature adjustments for your electric fan. A bulb at the end of the capillary tube is designed to probe or be attached to the top or hottest portion of the radiator. The adjustment knob may be used to set a precise temperature desired for fan activation. The mounting bracket is made of brushed stainless steel for good looks and durability. The complete kit includes the thermostat with bracket, a 30 amp relay, a 30 amp circuit breaker for over-all protection, wiring, terminals, and mounting hardware.

Specs on Adjustable Fan Thermostat:

- Temp range: -32 ° to 248 ° F
- Accuracy: +/- 7.3 ° F
- Differential: 7.3 ° +/- 3.6 ° F

Note: Temperature refers to the temp of the capillary tube, not the coolant temp.

30104.96.00

Adjustable Thermostat Kit Without Relay

30112.75.00



WEATHERPROOF ELECTRIC FAN RELAY KITS

For the harsh conditions encountered off-road, these relay kits provide complete protection from the elements and ensure reliable and dependable performance. These kits utilize heavy duty waterproof relays, weatherproof circuit breaker covers and extreme condition weatherproof shrinkable crimp-on terminals.

Weatherproof Electric Fan Relay

30130.58.00

Weatherproof Electric Fan Relay with 200 ° On/ 185 ° Off Thermostat

30128.99.00

Weatherproof Electric Fan Relay with 185 ° On/ 170 ° Off Thermostat

30129.99.00



FAN-THOM ELECTRIC FAN RELAY

Designed as inexpensive protection for your electric fan. Provides constant voltage, protects form voltage and amperage spikes and keeps fan from feeding back through the system. An absolute necessity if adding an on/off switch to your electric fan circuit.

30101.32.00



JUNCTION BLOCK

The right solution for attaching large gauge wire connections.

80112.11.00

REPLACEMENT THERMOSTAT

(Sold separately if needed)

(200-180 degrees) 3011042.00

(185-170 degrees) 3011142.00



FAN-THOM II ELECTRIC FAN RELAY WITH THERMOSTAT PROTECTION

Don't want to probe your radiator? The Fan-Thom II comes with a threaded thermostat that screws into the engine block or manifold for a professional installation. Thermostat thread size: 3/8"-18NPTF fitting.

200 ° On/ 185 ° Off

30102.75.00

185 ° On/ 170 ° Off

30103.75.00



STRIP LED (RED)

Use for third brake light 43/4" long.

80222.14.00



COURTESY LIGHT KITS
 GM Kit includes: GM door switches, wires and light sockets to install courtesy lights inside your vehicle.
 30702.38.00
 Universal Kit includes: Universal door switches, wires and light sockets to install courtesy lights inside your vehicle.
 30710.38.00

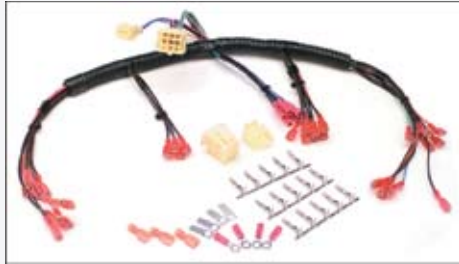

For cable driven speedometers



For electric speedometer

UNIVERSAL GAUGE HARNESS
 If you need to keep your under-dash area organized or you think that you need to remove gauges from time to time then you need to install our universal gauge harness. It will connect all major brand gauges including Auto Meter and VDO and works with most dash layouts and sizes.
 For cable driven speedometers
 30301.75.00
 For electric speedometer
 30302.80.00



HEI PIGTAIL
 Replacement pigtail for HEI distributor.
 30809.12.00



GM STEERING COLUMN AND DIMMER SWITCH PIGTAIL KIT
 Original factory connectors to replace worn out or damaged connectors for early GM keyed steering columns. GM color-coded wires are ready to connect into your existing harness. Includes: two keyed ignition switch pigtails, one turn signal pigtail with two connectors, one dimmer switch pigtail. Wire length: 12".
 30805.56.00

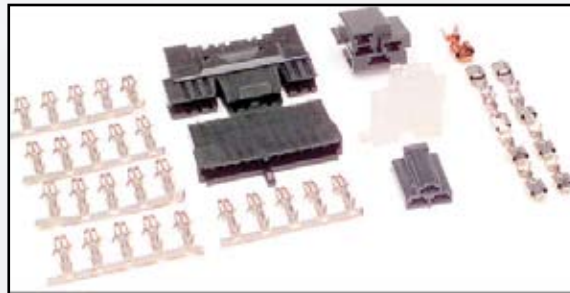

GM COLUMN CONVERSION KIT
 All the plugs and terminals for your early GM keyed steering column in one kit. Contains two ignition switch connectors, two turn signal connectors and one dimmer switch connector and terminals for each.
 30806.25.00



REPLACEMENT SWITCH KIT WITH IGNITION SWITCH
 One 3 position headlight switch, one floor mounted dimmer, two GM style grounding door jam switches, and one universal ignition switch with keys.
 80121.55.00

UNIVERSAL IGNITION SWITCH
 Dash mounted ignition switch with two keys.
 80153.14.00



New !

DIMMER SWITCH
 Floor mounted.
 80150.8.00



UNIVERSAL WINDSHIELD WIPER SWITCH
 Three position switch with on-off and windshield washer function.
 80173.27.00



FIBERGLASS BODY GROUND KIT
 For proper electrical grounding of any vehicles with fiberglass bodies.
 40026.41.00



GM STYLE JAMB SWITCH
 80170.4.00

REPLACEMENT SWITCH KIT
 Three position headlight switch, and floor mounted dimmer, and two GM style grounding door jam switches.
 80120.41.00





WHY USE URETHANE?

Production vehicles are built using rubber bushings in control arms, strut arms, leaf springs, body mounts, transmission mounts, sway bars and shocks. Additionally, rubber components can be found on coil spring pads, leaf spring pads and suspension bump stops. Not only are rubber components on the soft side to accommodate the typical car or truck buyer, but they tend to deteriorate rapidly. This contributes to premature failure, a "spongy" ride and less than ideal performance handling. Urethane can correct these conditions, while improving drivability.

DESIGNED TO FIT

PROTHANE'S™ design and engineering staff is dedicated to producing the highest quality urethane components on the market today. This goal is achieved through attention to detail, in house machining of master tools to exacting specifications and genuine appreciation for true performance. With all aspects of design and development under one roof, the design team, R&D department and master machinists are able to provide you with high quality parts that are designed to fit.



The total kit contains all the specific body rubber mounts and suspension rubber components needed to complete your truck.

All in One TOTAL KIT - Black Urethane

1963-66 Chevy/GMC 1/2 Ton 2WD

Includes body mounts, control arm rear bushings, tie rod boots, track arm rear bushings & transmission mounts.

7-2023 kit..... 177.54

1967-72 Chevy/GMC 1/2 Ton 2WD

Includes body mounts, sway bar bushings, tie rod boots, track arm rear bushings & transmission mounts.

7-2024 kit..... 193.08

1973-80 Chevy/GMC 1/2 Ton 2WD

Includes body mounts, front control arm bushings, rear spring shackle bushings, sway bar bushings, tie rod boots and transmission mounts.

7-2016 kit..... 327.39

For 3/4 Ton or 4WD kits - Inquire for Availability

BODY & CAB MOUNTS

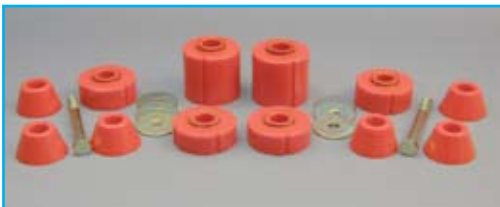

1963-66 Chevy/GMC 1/2 Ton 2WD

P6066-9023-MK (8 pc kit)..... 89.95

1967-72 Chevy/GMC 1/2 Ton 2WD

P6772-9023-AK (12 pc kit)..... 89.95

1973-80 Chevy/GMC 1/2 Ton 2WD

P7380-9023-AK (12 pc kit)..... 99.95

SPRING & SHACKLE BUSHING KIT



REAR Spring Eye & Shackle Bushings

1967-87 Pickup 1/2, 3/4 & 1 Ton with up to 2000 lb spring ratio (with 1-1/2" OD Frame Shackle Bushings)

7-1001 kit..... 70.98

REAR Frame Shackle Bushings

1973-87 Pickup 1/2, 3/4 & 1 Ton (1-1/2" OD)

7-803 kit..... 24.36

SWAY BAR BUSHINGS

Front - 1967-87 Pickup 2WD 1/2 Ton (with 1-1/16" Bar)

P6791-7243-1116 kit..... 19.95

(with 1-1/4" Bar)

P7391-7243-114 kit..... 19.95



NOTE: All urethane bushings on this page are standard **BLACK** in color. Red is available upon special order only.



HIDDEN DOOR HINGE KIT
 Why pay more for less when you can get the best kit available. Made only from high quality steel. It features a fully bushed one piece swing arm with a 3/8" ground shoulder

bolt hinge pin. This combination ensures reliability and strength. It is pre-aligned and welded to 1" square tubing making the installation process faster and easier. All hinge kits come complete with mounting hardware, recess pockets for two doors, extra bracing and installation instructions.

HK 001 each 225.00

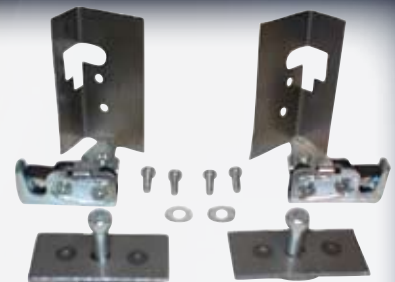

MINI BEAR CLAW LATCH
 Includes adjustable striker and installation plate. Sold each.

MBC 003 21.95

MINI BEAR CLAW LATCH KIT
 Includes striker bolts and installation kit. Sold in pairs.

MBC 004 48.95



SLIM LINE DESIGN LATCHES
 Bear Claw Latches for narrow doors and window clearance. 3/4" thick, 1 1/4" wide, and 3 7/8" long. Made from 14 gauge steel, these installation kits simplify installing bear claw latches. The latch door panels come pre-stamped to fit the Slim Line Latches. The cage nut striker allow up to a 1/2" adjustment, aiding door alignment. Installation kit includes 2 latch plates and 2 striker plates.

Slim Line Latches with Installation Kit
 BCS 003 80.00



SLIM LINE MANUAL LATCHES
 Bear claw latches with manual safety locks. Striker bolts included. Sold in pairs.

BCS 06 75.00



POWER BEAR CLAW
 Eliminate your door handles with a new Power Bear Claw Latch. Open your door inside or outside with button or keyless entry. Comes with strikers, installation bolts and 5 pole switch. Sold in pairs.

BP 002 each 95.00



SLIM LINE POWER
 Bear claw latch with power locks. Striker bolts included. Sold in pairs.

BCP 001 110.00



POWER WINDOW SWITCH
 Use with your original handle. No relays needed. Touch the window crank and the window automatically rolls up or down. Fits Chevy or Ford®. Sold in pairs.

PWS 01 124.95



TILT HOOD LIFT
 This motorized unit will extend 8 to 12 inches and lift up to 250 lbs. Good for trunks, hoods, or tilt front ends.

HTL 01 225.00



BEAR CLAW LATCHES

Dual rotary latch kit with four bolt hole pattern or the single latch kit with three hole bolt pattern. Includes 2 latches, strikers and mounting bolts. Large latch is 4 1/2" long x 1 3/4" x 3/4" thick. Medium latch is 3 1/2" long x 1 1/2" wide x 5/8" thick.

- Large
- BC 001A 40.00
- Medium
- BC 001B 40.00

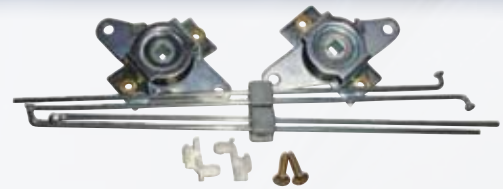

OUTSIDE DOOR HANDLE MOUNTING KIT

Spring loaded with center return. Finished in zinc coating, it can also be used with our bear claw latch kit. Available in 5/16".

- HL 001 35.00



DOOR PROPS

These one of a kind stainless polished door props will fit all bear claw latches.

- DP 01 39.95

BEAR CLAW INSTALLATION KIT

Made from 14 gauge steel, these installation kits simplify installing bear claw latches. The latch door panels come pre-stamped to fit single or dual rotary latches. Our cage nut striker panels allow up to a 1/2" adjustment, aiding door alignment. Comes with 2 latch plates and 2 striker plates. With Four Bolt Hole Pattern



- BC 002A 45.00



SMALL DOOR PROPS

Constructed of polished stainless steel and aircraft aluminum, these small uniquely designed door props will fit most bear claw latches.

- DP 01B 49.95



FLUSH MOUNT HOOD LATCH

With safety catch. Comes complete with mounting bolts.

- HT 04 54.95



POWER COWL VENT

Tired of tugging your handle? Get a Rocky Power Cowl Vent! This power cowl vent motor and gear box is constructed of high grade aluminum and is equipped with an adjustable micro switch that stops the cowl vent when it is completely closed. A must have item when adding A/C to your car.

- OVC 01 80.00



MECHANICAL LATCH ACTIVATOR

This mechanical latch activator mounts inside the door and is operated by the outside door handle. The spring loaded mechanism returns the handle to the proper position. Comes complete with right and left latch activators, two clips, and adjustable door rods.

- MLA 01 40.00



ALUMINUM DRESS UP KIT

A quick and simple way to activate your bear claw latches from the interior of your car. Made from billet aluminum. Complete for two doors.

- ADK 01 25.00



CHROME ENGINE KIT

Fits 1958-86 Small Block Chevrolet 283-400

Includes:

Stock Height Baffled Valve Covers - 8 T-bar hold downs
Breather - Push in PCV breather - PCV braided stainless steel hose & fittings - Twist in Oil filler cap - Grommets

54083 set.....79.95



DELUXE CHROME ENGINE KIT

Fits 1958-86 Small Block Chevrolet 283-400

Includes:

Stock Height Baffled Valve Covers - 8 Spreader Bars
8 T-bar hold downs - Breather - Dipstick & Tube
Grommets - Timing Cover Kit - Timing Tab

5403 set.....78.95



DELUXE CHROME ENGINE KIT

Fits 1958-86 Small Block Chevrolet 283-400

Includes:

High Profile Baffled Valve Covers - 8 Spreader Bars
8 T-bar hold downs - Breather - Dipstick & Tube
Grommets - Timing Cover Kit - Timing Tab

5404 set.....93.95



CHROME ENGINE KIT

Fits 1965 and Later Big Block Chevrolet 396-454

Includes: High Profile Baffled Valve Covers - 8 Spreader Bars - 8 T-bar hold downs - Breather - Dipstick & Tube - Grommets - Timing Cover Kit - Timing Tab

5404 set.....93.95



CHROME ENGINE KIT

Fits 1965 and Later Big Block Chevrolet 396-454

Includes: Stock Height Baffled Valve Covers - 8 Spreader Bars - 8 T-bar hold downs - Breather - Dipstick & Tube - Grommets - Timing Cover Kit - Timing Tab

5405 set.....93.95

1955-59 Chevy Pickup Frames & Chassis

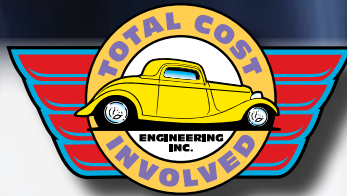

1955-59 Chevrolet Pickup Frame		
Description	Part #	Price
Mustang II coil-over rear	133-1002-00	3239.00
Custom IFS coil-over rear	133-1001-00	3239.00
Mustang II leaf rear	133-1013-00	3239.00
Custom IFS leaf rear	133-1012-00	3239.00
Options		Add
Frame stepped above axle	113-1913-00	266.00

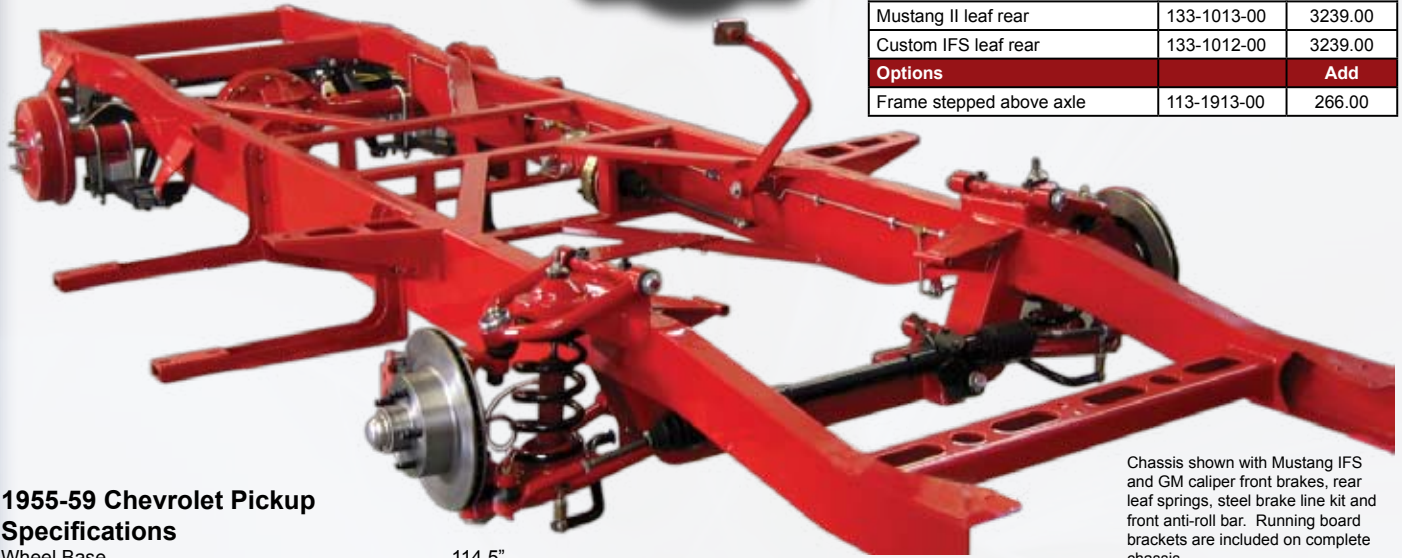

1955-59 Chevrolet Pickup Specifications

Wheel Base	114.5"
Frame Length	180.5"
Width	52.5" at body mount
Front Wheel Mounting.....	59"
Rear Wheel Mounting.....	60" or your choice
Weight as Pictured	800 lbs.

Chassis shown with Mustang IFS and GM caliper front brakes, rear leaf springs, steel brake line kit and front anti-roll bar. Running board brackets are included on complete chassis.

Pickup Base Chassis Components List	Chrome	Stainless
Frame	√	√
Engine Mounts (SB Chevy)	√	√
Trans Mount (350, 400 700R4)	√	√
Complete Mustang II or Custom IFS	CS	CS
Brake Pedal and Bracket	√	√
Rear Axle Housing with Axles	√	√
Rear Parallel Leaf Spring Kit	√	√
Rear Shocks	√	√
Complete Chassis including All Components above & below		
Power Brake Booster and Master Cylinder	√	√
Front & Rear Braided Brake Hoses	√	√
Proportional Valve	√	√
Stop Light Switch	√	√
Steel Brake Lines Installed	√	√
Rear Drum Brake Kit	√	√
3rd Member	√	√
Chrome Brake Pedal Pad	√	√

1955-59 Chevrolet Pickup Chassis	Part #	Price
Base Chassis Mustang IFS/Leaf Rear	133-1240-00	6433.00
Base Chassis Custom IFS / Leaf Rear	133-1230-00	6650.00
Complete Chassis Custom IFS / 4 link Rear	133-1225-00	8322.00
Complete Chassis Custom IFS / 4 link Rear Chr/Stl	133-1225-02	8322.00
Complete Chassis Custom IFS / Leaf Rear	133-1235-00	8214.00
Complete Chassis Custom IFS / Leaf Rear Chr/Stl	133-1235-02	8971.00
Complete Chassis Custom IFS w/ Air	133-1285-00	10,285.00
Complete Chassis Custom IFS w/ Air Chr/Stl	133-1285-02	10,810.00
Complete Chassis Mustang IFS / Leaf Rear	133-1245-00	7674.00
Complete Chassis Mustang IFS / Leaf Rear Chr/Stl	133-1245-02	8106.00

Chassis Upgrade Options	Part #	Add
Frame stepped above axle	113-1913-00	266.00
Engine Mounts (other than SB Chevy)	100-1907-00	212.00
Rear 4-link / Coil-Over Suspension	413-4902-00	234.00
Rear Anti-Roll Bar / 4-link	412-4856-00	254.00
Aluminum Adjustable Coil-Over (Rear)	400-4930-03	128.00
Stainless / AN Brake Lines	600-6920-00	159.00
Front Billet Air Spring (Custom IFS)	400-4941-00	499.00
Front Air Spring Suspension (Mustang II)	400-4421-00	212.00
12" Drilled Rotor w/polished 4-piston Caliper / IFS	600-6917-12	585.00
13" Drilled Rotor w/polished 6-piston Caliper / IFS	600-6918-12	1648.00
12" Drilled Rotor w/polished 4-piston Caliper Mustang II	600-6922-12	731.00
13" Drilled Rotor w/polished 6-piston Caliper Mustang II	600-6923-12	1812.00
Hi-Tech Rear Disc (Pol 4-Piston)	600-6906-03	689.00
Hi-Tech Rear Disc (GM Caliper)	600-6930-00	307.00
Black Powder Coated A-Arms	200-2905-05	96.00
Stock Height Spindles (Mustang II only)	200-2920-00	Exchange
These upgrades are in addition to the above cost table		

Mustang II Air Spring Option



13" Brake

CHEVY PICKUP

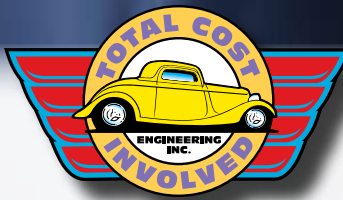

CUSTOM IFS

TCI custom IFS units caster and camber adjustment is made simple with adjustable stainless eccentrics.

Every plain IFS features: Crossmember, 1" upper and 1-1/8" lower tubular A-arms, new manual rack & pinion steering gear (power rack available), 11" disc brakes, adjustable billet coil-overs with black powder coated springs (optional chrome), and anti-roll bar. Available with black powder coated A-arms, and polished billet shock and-chrome springs.



Custom Show IFS features: Polished stainless A-arms, chrome steering arms, chrome spindles, chrome anti-roll bar, chrome hiem links, and polished billet coil-overs.

Plain IFS comes with GM brakes, show IFS comes with custom 11" brakes with optional 12" brakes, and 6-piston 13" brakes. Available with optional billet air spring, Rotor, spindles and brake units come assembled with bearings packed with hi-temp grease.



13" Brake Option



Billet Air Spring Option



Alignment Feature Adjustable Eccentric



GM Brake

Description	Part #	Price
'47-54 Chevy Custom IFS	232-2202-00	2599.00
'55-59 Chevy Custom IFS	233-2202-00	2599.00
Optional Upgrades to add to the above	Part #	Add
Show Option	Change 00 to 12	850.00
Custom Brakes	600-6902-12	265.00
12" Drilled Rotors w/polished 4-piston calipers	600-6917-12	585.00
13" Drilled Rotors w/polished 6-piston calipers	600-6918-12	1648.00
Chrome Springs (pair)	400-4905-01	63.00
Billet Air Springs	400-4940-02	499.00
Power Rack	300-3912-00	165.00
Black Coated A-Arms	200-2905-05	96.00



CHEVY PICKUP

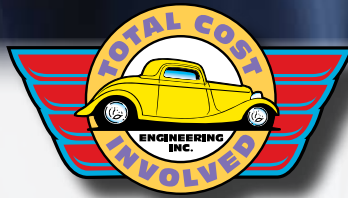

MUSTANG II IFS

The Mustang II IFS unit features: Crossmember, coil spring-shock towers, 1" tubular A-arms, spindles (stock height or 2" drop), new manual rack and pinion gear, 11" disc kit, black powder coated springs and painted shocks.

Options available: Polished stainless A-arms, black powder coated A-arms, power rack & pinion steering gear, anti-roll bar (plain or chrome), air spring suspension, 12" brakes or 13" brakes, rotor, spindles and brake units come assembled with bearings packed with grease.

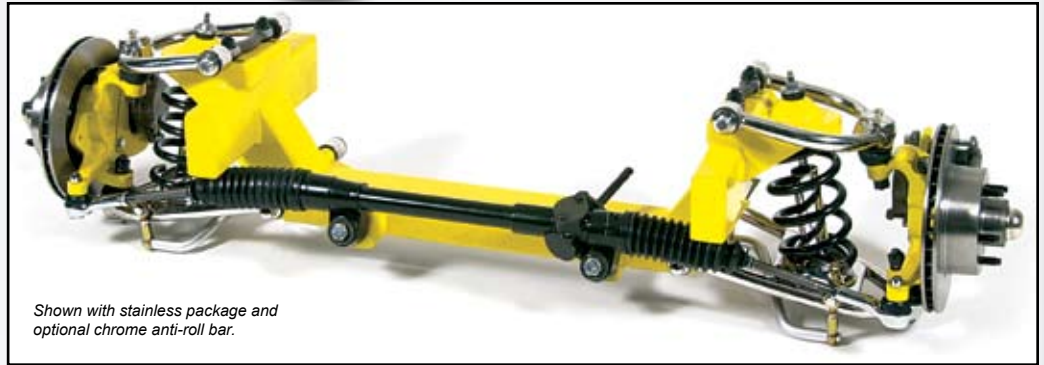

Shown with stainless package and optional chrome anti-roll bar.



12" Brake

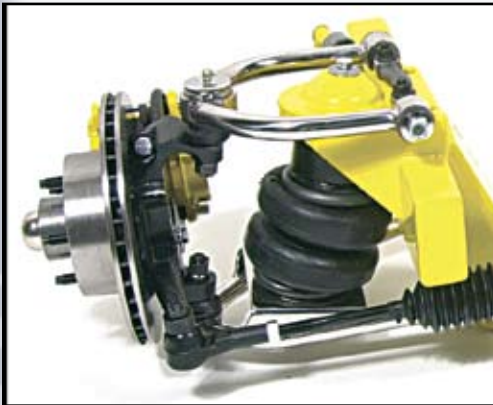

Air Spring Option



Anti-Roll Bar Option

Description	Part #	Price
'37-39 Chevy Pickup	230-2354-00	1750.00
'40-46 Chevy Pickup	231-2354-00	1750.00
'47-54 Chevy Pickup	232-2354-00	1750.00
'55-59 Chevy Pickup	233-2354-00	1750.00
Optional Upgrades to the above	Part #	Add
Stainless A-Arms	200-2902-02	243.00
Black A-Arms	200-2905-05	96.00
Anti-Roll Bar	400-4916-00	191.00
Anti-Roll Bar (Chrome)	400-4916-01	276.00
Power Rack	300-3912-00	165.00
Air Spring Kit	400-4420-00	212.00
Stock Height Spindles	200-2920-00	Exchange
12" Drilled Rotors w/polished 4-piston Calipers	600-6922-03	731.00
13" Drilled Rotors w/polished 6-piston Calipers	600-6923-03	1812.00



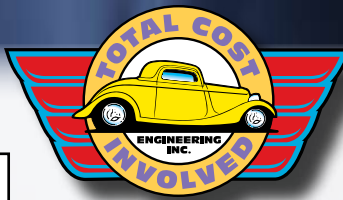

MUSTANG II CROSSMEMBER KITS

Includes: Crossmember, coil spring-shock towers, strut rod brackets and boxing plates. *Specify application: stock arms or tubular arms.*

- 1936-39 Chevy Pickup
230-2356-00 403.00
- 1940-46 Chevy Pickup
231-2356-00 403.00
- 1947-54 Chevy Pickup
232-2356-00 403.00
- 1955-59 Chevy Pickup
232-2356-00 403.00



TRANSMISSION MOUNTS - Bolt in style (will fit most transmissions)

- 1947-54 Chevy Pickup 732-7512-00 82.00
- 1955-59 Chevy Pickup 713-7512-00 82.00



WELD ON STYLE ENGINE MOUNTS

Designed to mount engines into Chevy chassis using factory rubber mounts for Chevy V8 engines.

- 1947-54 - 732-7010-00 77.00
- 1955-59 - 732-7012-00 77.00

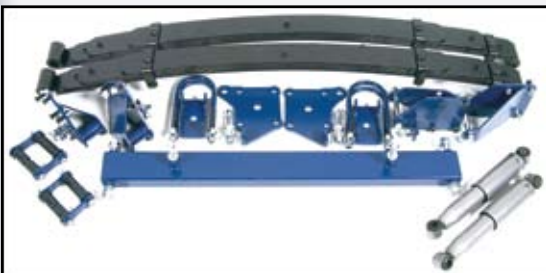

REAR LEAF SPRING KITS

Bolt in rear leaf kit lowers your truck 4" and features leaf springs, shock kit, mounting brackets, weld-on axle brackets, hardware, and instructions.

- 1947-54 Pickup - 432-4610-00 488.00
- 1955-59 Pickup - 433-4610-00 488.00



PICK-UP 9" FORD AXLE ASSEMBLY. We are offering a new round back Hot Rod style 9" Ford rear axle assembly narrowed with new 28 splined axles and bearings. Complete unit features 3rd member with new gear set at (3:00 to 4:11), new bearings and seals, new 11" drum brake, brackets and gear lube.

- 1947-54 Chevy Complete Assembly**
- (Leaf Spring Brackets) - 532-5007-00 2097.00
- (Coil-Over Brackets) - 532-5005-00 2097.00
- (Air Spring Brackets) - 532-5020-00 2097.00

OPTIONAL UPGRADES - Add to the cost of the assembly

- Hi-Tech Disc (Wilwood) - 600-6903-03 689.00
- Hi-Tech Disc (GM) - 600-6930-00 307.00
- Posi Unit - 500-5962-00 450.00
- Fast Axles - 500-5964-00 147.00
- 4 3/4" Bolt Pattern - 100-1940-00 Exchange



COMPLETE REAR 4-LINK KITS

Kit features: 1" bars, 3/4" stainless adjusters, urethane bushings, housing brackets, bolt-on frame brackets, cross-member, coil-over shocks (Air Spring optional), track bar and hardware. Available in plain, chrome or polished stainless. Specify centered or un-centered housing.

Description	Part #	Price
1947-54 Pickup 4-link (coil overs)	532-5102-00	863.00
1947-54 Pickup 4-link (air spring)	532-5120-00	984.00
1955-59 Pickup 4-link (coil overs)	533-5102-00	863.00
1955-59 Pickup 4-link (air spring)	533-5120-00	984.00
Optional Upgrades to the Above	Part #	Add
Chrome Option	Change 00 to 01	214.00
Stainless Option	Change 00 to 02	553.00
Billet Anti-Roll Bar Kit	412-4856-00	254.00

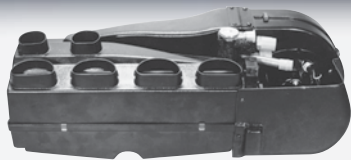

Because the new **GEN-II** Technology incorporates so many revolutionary ideas and features, we get some frequently asked questions from customers. And, we hear some unfortunate disinformation coming from other "air conditioning companies". Here's what you need to know when buying a Vintage Air System.

Are the Gen-II Systems really different?

Vintage Air is the only performance air conditioning company that designs and manufactures ALL of their products with industry standard Pro Engineering CAD/CAM systems. Rather than trial and error or repackaging ten year old product designs, they continually refine existing systems and develop new systems to deliver true climate control such as you would find in the finest production automobiles. In fact, they provide the climate control system for some of the worlds finest car makers!

What is the point of using servo motors?

Servo motors are not simply on-off electric switches found in some aftermarket A/C systems. They are variable position solid-state devices used reliably on high-end OEM systems for years. Servo motors in properly designed systems can deliver much greater air door travel. This allowed us to design from scratch with tremendous volume increases in all three of the new Gen-II systems. Conventional vacuum operated air doors simply do not open far enough to flow as much air as the Gen-II's.

Servo's are not cheap. Nor are they just a bolt-in change. That is why no other company offers them, and why they try to discourage customers from wanting a servo system. When combined with the exclusive solid state circuit board controls, the Gen-II servo's can give you the most infinite adjustments for "Just Right Temperature" in any weather or location.

Can the case design make that much difference?

All you have to do is see the "virtual" flow testing they perform on the engineering computer work stations to understand. They can test, refine, and retest the most minor case design changes or components until they are satisfied that the system is delivering everything it has got - before they even build a proto-type. They then install a system into one of the R&D hot rods and drive it thousands of miles - before you ever buy one for your own hot rod. Just like the professional race teams, they know winning is in the smallest details!

Can the Gen-II deliver better defrost too?

One of the most important design ideas they learned with their in-house CAD engineering program was how to design for optimum dehumidified defrost mode. Clearing the fog from your windows on a mild, yet humid day is a snap with the new Gen-II systems.

Do I have to be a computer programmer?

While the new electronic controls and servos are state-of-the-art, the Gen-II systems are actually easier to install than old conventional type systems. No cables to route through the firewall because the heater valve is also servo controlled. No linkages to adjust because the controls are solid state circuit boards. And, you can mount the control panel almost anywhere in the car. Simply plug and play.

What about high horsepower engines?

The new Gen-II systems do not need engine vacuum. All functions are controlled with electronic servos so your climate control will not be affected even when you're powering up a mountain pass.

Why is the warranty three years?

Since the original day they sold their first system back in 1976 they have always gone the "extra mile" to satisfy customer needs. Ask any Vintage Air owner. The fact is, when installed as directed, Vintage Air systems have less than one tenth of one percent defects! They could offer a longer warranty, but in their 26 years of experience, they tell us that in the very rare times a part has failed, it has failed in the first few months of operation. There are thousands more Vintage Air systems on the road today that all other brands combined. They are the industry standard!

The most important part of any warranty is the reputation and longevity of the company which stands behind it.



1947-55 CHEVY/GMC TRUCK

Gen-II SURE FIT SYSTEM

Gen-II Sure Fit air conditioning, heating and defrost systems for '47-55 Chevy/GMC trucks are designed specifically for each application. Get true bi-level air flow and OEM quality "just right temperature" control.

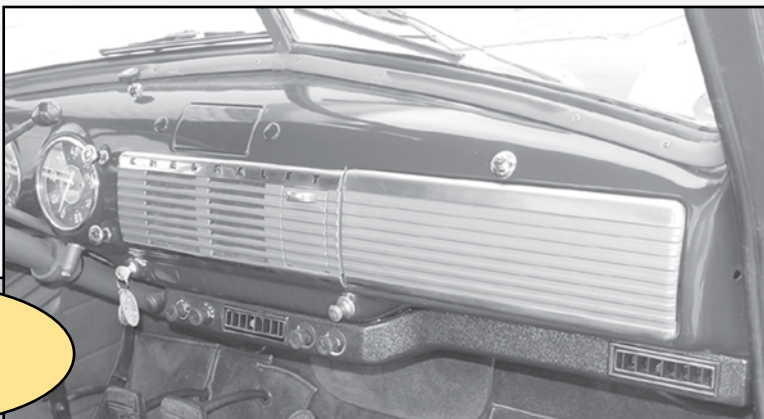

Gen-II Technology System!



1947-55 Gen II Chevy/GMC Truck-Sure Fit System Features:

- Electronic Servo Motor Controls, Including Heater Valve
- Mounts Completely behind dash
- A/C exits thru dash or side vents
- Floor or dash exit heat
- Dehumidified defrost
- Compatible with optional Gen-II proline controls

The All-In-One Gen-II kit for your Truck!

COMPLETE KIT: Original deluxe control assembly in your dash connects to and controls this unit. Designed to mount to existing holes in your dash and firewall without drilling or fabrication. It comes complete with all mounting brackets, hardware, louvers, duct hose, wiring harness, condenser & drier package (condenser, mounting brackets, standard drier, pre-formed aluminum lines and mounting hardware) and a complete set of installation instructions.

1947-55 Chevy/GMC Truck Complete Kits
 for 134a Refrigerant.....**74044-LCU-A \$1,095.00**
 for R-12 Refrigerant.....**74044-LCU \$1,095.00**
Polished Compressor Upgrade - Add \$50.00 to cost



Vintage Air Sure Fit system evaporators install completely inside the cab for a clean, original looking engine compartment. Firewall plate mounts to original holes.



1955-59 CHEVY/GMC TRUCK

Gen-II SURE FIT SYSTEM

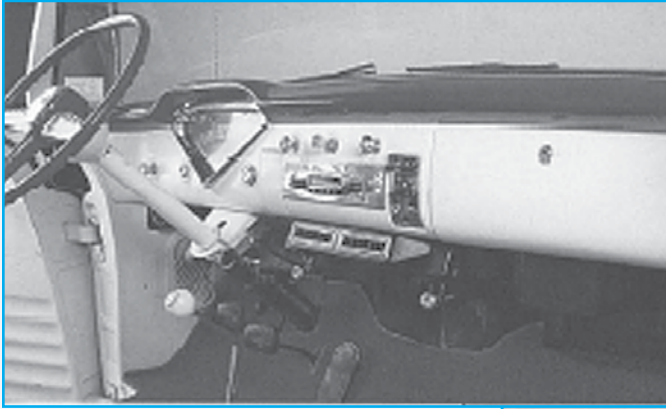

Vintage Air Sure Fit air conditioning, heating and defrost systems for the Classic Chevy's are designed specifically for each application. They match the coil and blower to give you the maximum amount of comfort in your truck. Factory deluxe controls are used.

1955-59 Gen II Chevy/GMC Truck Sure Fit System

Features:

- Mounts Completely behind dash
- A/C exits at dash
- Floor exit heat
- Dehumidified defrost
- Smooth firewall



The All-In-One Gen-II kit for your Truck!

COMPLETE KIT: Original deluxe control assembly in your dash connects to and controls this unit. Designed to mount to existing holes in your dash and firewall without drilling or fabrication. It comes complete with all mounting brackets, hardware, louvers, duct hose, wiring harness, condenser & drier package (condenser, mounting brackets, standard drier, pre-formed aluminum lines and mounting hardware) and a complete set of installation instructions.

1955-59 Chevy/GMC Truck Complete Kits

for 134a Refrigerant.....74045-LCU-A \$1,095.00
for R-12 Refrigerant.....74045-LCU \$1,095.00

Polished Compressor Upgrade - Add \$50.00 to cost



OPTIONAL UPGRADE
Replacement Control
Panel # 49755-LCI \$150.00





1960-72 CHEVY/GMC TRUCK

Gen-II SURE FIT SYSTEM

Vintage Air Sure Fit air conditioning, heating and defrost systems for '60-72 Chevy trucks are designed specifically for each application. They match the coil and blower to give you the maximum amount of comfort in your vehicle, greater air flow than your OEM system provided, and still retain the factory look inside your vehicle. Your factory controls are used.



1960-72 Gen II Chevy/GMC Truck Sure Fit System

Features:

- Mounts Completely behind dash
- A/C exits thru dash vents
- Floor exit heat
- Dehumidified defrost
- Smooth firewall

The All-In-One Gen-II kit for your Truck!

COMPLETE KIT: Original deluxe control assembly in your dash connects to and controls this unit. Designed to mount to existing holes in your dash and firewall without drilling or fabrication. It comes complete with all mounting brackets, hardware, louvers, duct hose, wiring harness, condenser & drier package (condenser, mounting brackets, standard drier, pre-formed aluminum lines and mounting hardware) and a complete set of installation instructions.

1960-63 Chevy/GMC Truck Complete Kits

for 134a Refrigerant.....74060-LCU-A \$1,095.00

for R-12 Refrigerant.....74060-LCU \$1,095.00

1964-66 Chevy/GMC Truck Complete Kits

for 134a Refrigerant.....74065-LCU-A \$1,095.00

for R-12 Refrigerant.....74065-LCU \$1,095.00

1967-72 Chevy/GMC Truck Complete Kits

for 134a Refrigerant.....74067-LCU-A \$1,095.00

for R-12 Refrigerant.....74067-LCU \$1,095.00

Polished Compressor Upgrade - Add \$50.00 to cost

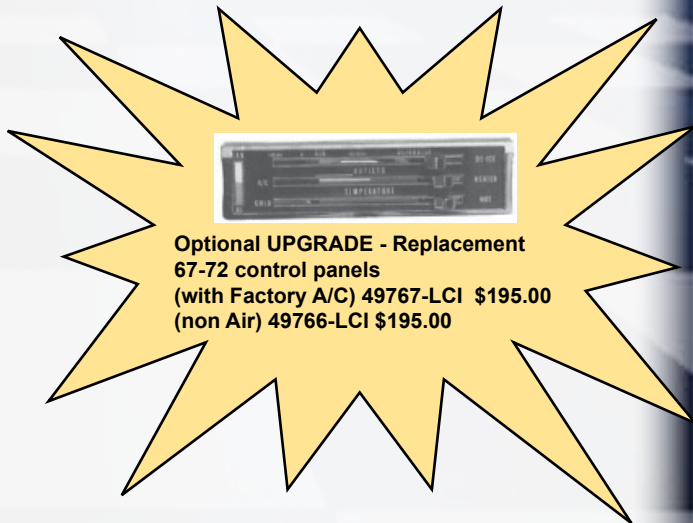

Optional UPGRADE - Replacement
67-72 control panels
(with Factory A/C) 49767-LCI \$195.00
(non Air) 49766-LCI \$195.00



1973-80 CHEVY/GMC TRUCK

Gen-II SURE FIT SYSTEM



Vintage Air Sure Fit air conditioning, heating and defrost systems for '73-86 Chevy/GMC trucks are designed specifically for each application. They match the coil and blower to give you the maximum amount of comfort in your vehicle, greater air flow than your OEM system provided, and still retain the factory look inside your vehicle. Your factory non-air system heater controls are used.

1973-80 Gen II Chevy/GMC Truck Sure Fit System Features:

- Mounts Completely behind dash
- A/C exits thru dash vents
- Floor exit heat
- Dehumidified defrost
- Smooth firewall

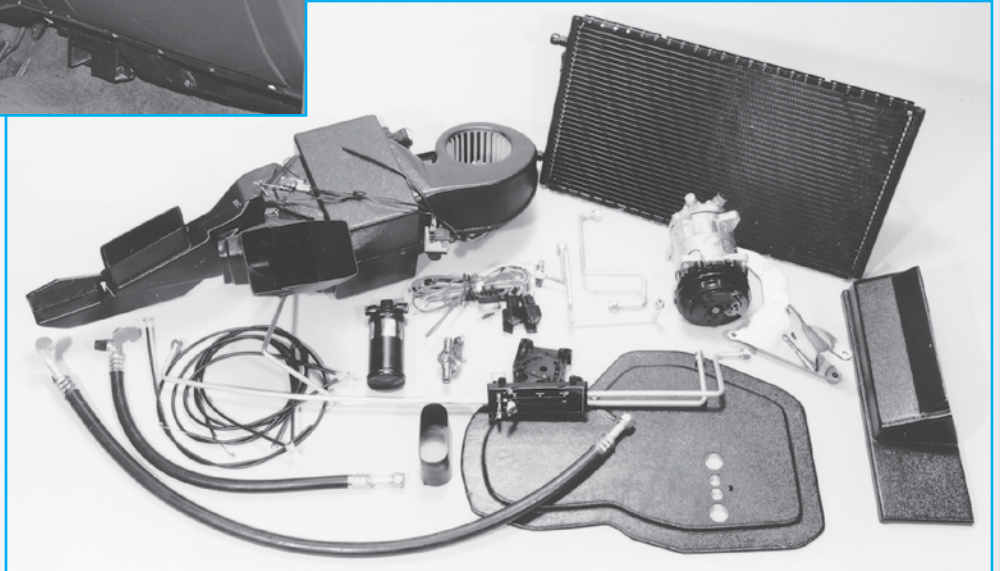

The All-In-One Gen-II kit for your Truck!

COMPLETE KIT: Original deluxe control assembly in your dash connects to and controls this unit. Designed to mount to existing holes in your dash and firewall without drilling or fabrication. It comes complete with all mounting brackets, hardware, louvers, duct hose, wiring harness, condenser & drier package (condenser, mounting brackets, standard drier, pre-formed aluminum lines and mounting hardware) and a complete set of installation instructions.

1973-80 Chevy/GMC Truck w/o Factory Air

for 134a Refrigerant.....74173-LCU-A \$1,095.00
for R-12 Refrigerant.....74173-LCU \$1,095.00

1973-86 Chevy/GMC Truck with Factory Air

for 134a Refrigerant.....74180-LCU-A \$1,095.00
for R-12 Refrigerant.....74180-LCU \$1,095.00

Polished Compressor Upgrade - Add \$50.00 to cost

NOTE: This kit uses your Original Controls.
No accessory controls available.

GEN-II SUPER COOLER

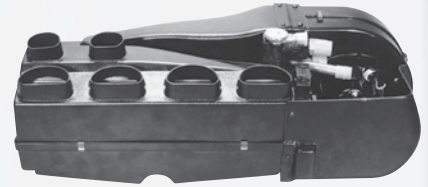

Gen-II Super Cooler Systems

Come complete with:

- Evaporator and Mounting Brackets
- Wiring Harness
- A/C Duct Hose
- Drain Kit
- Heater Control Valve
- Defrost Option Includes Hoses and Ducts

Choose In-Dash or Under-Dash Controls



Gen-II Systems available with our new 4-Lever dash mounted control panel. Horizontal or vertical style are both available.



4-knob pod for under dash or hidden control installation.

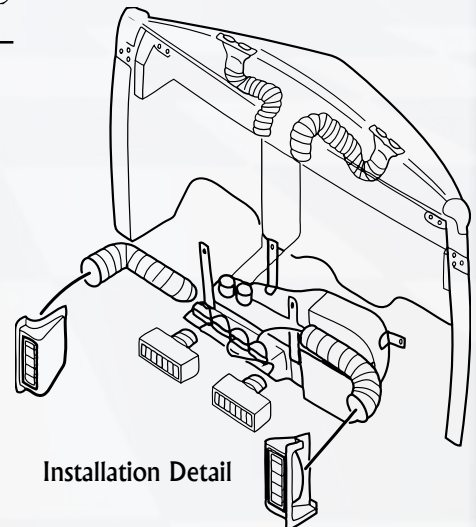

Installation Detail

THE ABSOLUTE PERFORMANCE LEADER! State of the art GEN-II servo motor control technology is now incorporated into the most popular heat and cool system. Amazing performance is achieved with the GEN-II Super's new "D" shaped air outlets. As an added benefit, you can position all 4 louvers wherever you need them. The ideal system for the largest sedans or wagons. Features true bi-level operations in cool and heat modes and a more powerful dehumidified defroster mode. **Now features servo-actuated adjustable heater valve.**

Gen-II Technology Benefits:

- High torque screw-drive servo motors control all butterfly airflow doors.
Increased travel on these doors allows much greater airflow.
Immediate response to control input and superior door sealing over vacuum controls.
- No reliance on engine vacuum - important with high performance engines.
- Re-engineered heating/cooling coil.
Increases cooling capacity by over 20%, and heating capacity by over 100%.
- Re-engineered and computer aided design to evaporator case.
Optimized internal case design allows significant airflow volume increases.
Increased capacity and control of dehumidified defroster airflow.
Blower fan motor isolated on rubber mounts for quiet running and longer life.

Dimension Detail

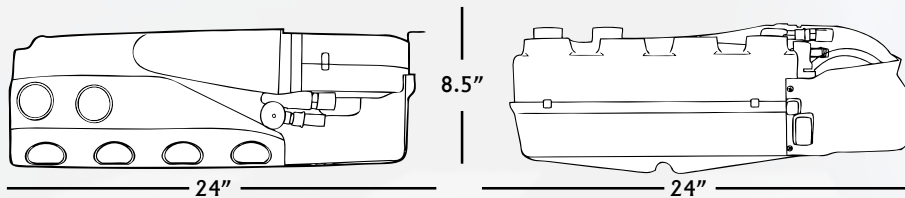

Please include the following information when ordering:

1. Year and Bodystyle
2. Engine Size
3. Control Style
4. Part Number

GEN-II SUPER COOLER

Heat & Cool (no louvers)	
61005-H/C	420.00
Heat & Cool with Std Louvers	
61005-H/CSTDLV	440.00
Heat, Cool, & Defrost (no louvers)	
61005-H/C/D	450.00
Heat, Cool, & Defrost with Std Louvers	
61005-H/C/DSTDLV	470.00

GEN-II SUPER COMPAC

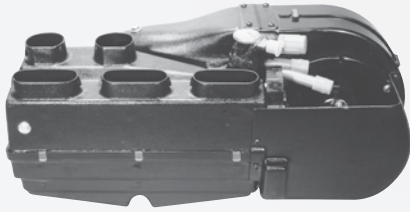

Gen-II Super Cooler Systems

Come complete with:

- Evaporator and Mounting Brackets
- Wiring Harness
- A/C Duct Hose
- Drain Kit
- Heater Control Valve
- Defrost Option Includes Hoses and Ducts

Choose In-Dash or Under-Dash Controls



Gen-II Systems available with our new 4-Lever dash mounted control panel. Horizontal or vertical style are both available.



4-knob pod for under dash or hidden control installation.

GEN-II COMPAC SYSTEM

Heat & Cool

68000-H/C 370.00

Heat & Cool with Std Louvers

68000-H/CSTDLV 380.00

Heat, Cool, & Defrost

68000-H/C/D 430.00

Heat, Cool, & Defrost with Std Louvers

68000-H/C/DSTDLV 440.00

AMAZING PERFORMANCE IN A COMPACT SYSTEM! State of the art Gen-II servo motor control technology makes this mid sized package work better than most other's full-sized systems. Amazing performance with three vents allowing you to position louvers wherever you need them. This is the ideal system for the coupes and smaller sedans and wagons. Features true bi-level operation in cool and heat modes and a more powerful dehumidified defroster mode. **Now features servo-actuated adjustable heater valve.**

Gen-II Technology Benefits:

- High torque screw-drive servo motors control all butterfly airflow doors. Increased travel on these doors allows much greater airflow. Immediate response to control input and superior door sealing over vacuum controls. No reliance on engine vacuum - important with high performance engines.
- Re-engineered heating/cooling coil. Increases cooling capacity by over 20%, & heating capacity by over 100%.
- Re-engineered and computer aided design to evaporator case. Optimized internal case design allows significant airflow volume increases. Increased capacity and control of dehumidified defroster airflow. Blower fan motor isolated on rubber mounts for quiet running & longer life.

Installation Detail

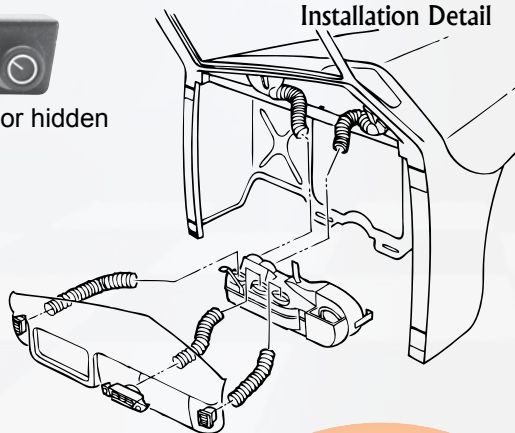

Dimension Detail

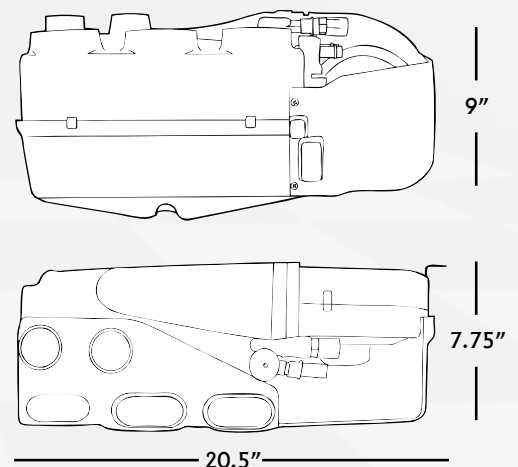

Please include the following information when ordering:

1. Year and Bodystyle
2. Engine Size
3. Control Style
4. Part Number

GEN-II MINI UNIT



Get the Same Capacity as the Original Compac Unit in a Smaller Size!



NEW! GEN-II TECHNOLOGY FOR THE SMALLEST CARS AND TRUCKS!

State of the art Gen-II servo motor control technology is now incorporated into the smallest heat and cool system. All new CAD designed case allows more capacity and air flow that the original Compac system. The ideal system for trucks and small hot rods. This features true bi-level operation in cool and heat modes and a more powerful dehumidified defroster mode. Also features exclusive servo-actuated adjustable heater valve.

Gen-II Super Cooler Systems

Come complete with:

- Evaporator and Mounting Brackets
- Wiring Harness
- A/C Duct Hose
- Drain Kit
- Heater Control Valve
- Defrost Option Includes Hoses and Ducts

Gen-II Technology Benefits:

- High torque screw-drive servo motors control all butterfly airflow doors. Increased travel on these doors allows much greater airflow. Immediate response to control input and superior door sealing over vacuum controls. No reliance on engine vacuum - important with high performance engines.
- Re-engineered heating/cooling coil. Increases cooling capacity by over 20%, and heating capacity by over 100%.
- Re-engineered and computer aided design to evaporator case. Optimized internal case design allows significant airflow volume increases. Increased capacity and control of dehumidified defroster airflow. Blower fan motor isolated on rubber mounts for quiet running and longer life.

Choose In-Dash or Under-Dash Controls



Gen-II Systems available with our new 4-Lever dash mounted control panel. Horizontal or vertical style are both available.



4-knob pod for under dash or hidden control installation.

Dimension Detail

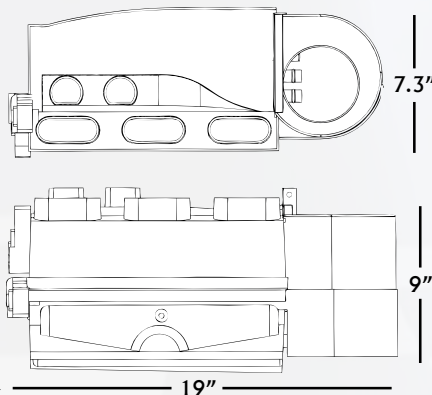

GEN-II MINI SYSTEM	
Heat & Cool	
66005-H/C	370.00
Heat & Cool with Std Louvers	
66005-H/C/STDLV	380.00
Heat, Cool, & Defrost	
66005-H/C/D	430.00
Heat, Cool & Defrost with Std Louvers	
66005-H/C/DSTDLV	440.00

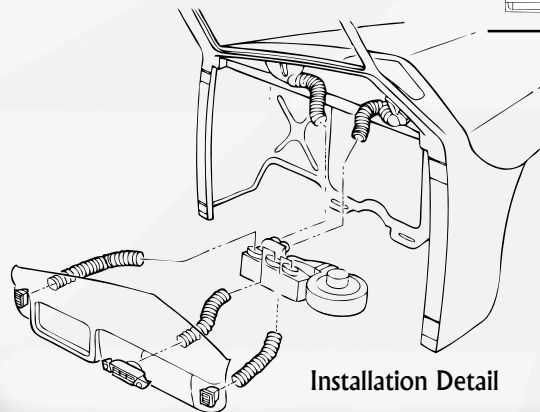

Installation Detail

Please include the following information when ordering:

1. Year and Bodystyle
2. Engine Size
3. Control Style
4. Part Number

SLIM LINE UNIT



Slim Line Systems

Come complete with:

- Under Dash Evaporator with Mounting Brackets
- Controls
- Drain Kit

SLIM LINE UNDER DASH SYSTEM

Heat, Cool, & Defrost

11300-VUZ-A. 325.00

Heat, Cool, & Defrost with Black Louvers

11400-VUZ-A. 325.00

SIMPLE BELOW DASH MOUNTING! This system has been engineered by Vintage Air with a matched blower motor and blower wheel to provide greater cooling capacity and air delivery than any other under dash unit on the market.

Controls - Built-in rotary knob controls.

Mounting - Under dash mounting doesn't disturb any of the behind-the-dash components such as radios or original heating systems.

Quality Control - Vintage Air's complete in-house engineering, design, and production facility ensure that you get a well designed, tested, and proven system because we control quality at every step.

Dimension Detail

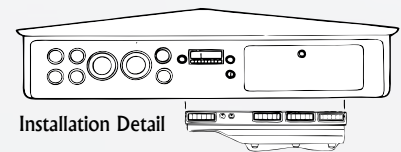
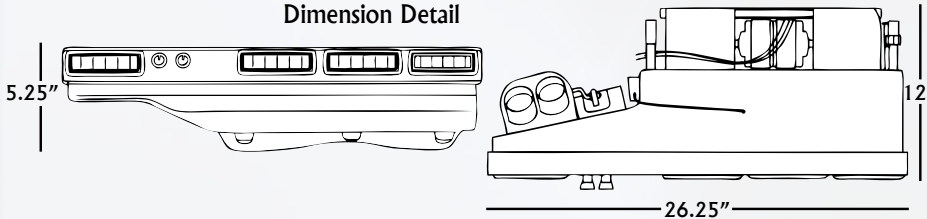

MINI SLIM LINE



Mini Slim Line Systems

Come complete with:

- Under Dash Evaporator with Mounting Brackets
- Controls
- Drain Kit

MINI SLIM LINE UNDER DASH SYSTEM

Cool only. Passenger side fittings.

10301-VUY-A. 272.00

Cool only. Passenger side fittings with black louvers.

10401-VUY-A. 272.00

SMALLEST BELOW DASH UNIT - A simple solution to A/C installation. This system has been engineered by Vintage Air with a matched blower motor and blower wheel to provide exceptional cooling capacity and air delivery. Choose driver side or passenger side connections.

Control - Uses standard under dash control pod.

Mounting - Under dash mounting doesn't disturb any of the behind-the-dash components such as radios or original heating systems.

Quality Control - Vintage Air's complete in-house engineering, design, and production facility ensure that you get a well designed, tested, and proven system because we control quality at every step.

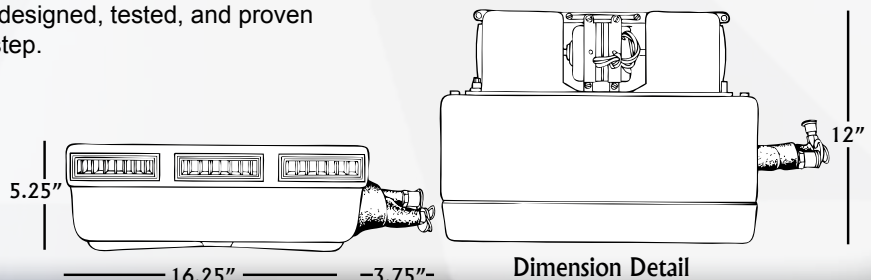
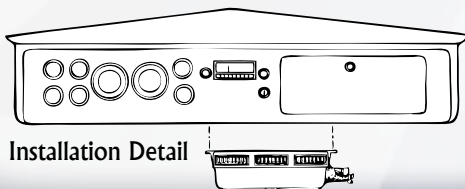

HEATERS



ALL NEW DESIGN! Bi-level system provides superior performance from Superflow coil technology and improved case design. New single cable/switch control operates both air door actuation and fan speed. Cable operated door now allows blending of heat between floor and ducts which can be used for defrost or with under dash vents in roadsters.

Heater Systems

Come complete with:

- Three Speed Blower
- Electric On/Off Water Valve
- Rotary Controls and Wiring Harness
- Includes Defrost Hoses and Ducts

BI-LEVEL HEATER
Heater with defrost.

50616-VUZ 249.00

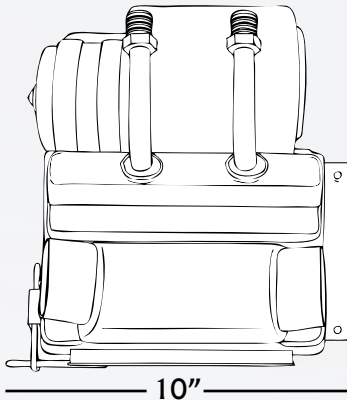

Front View

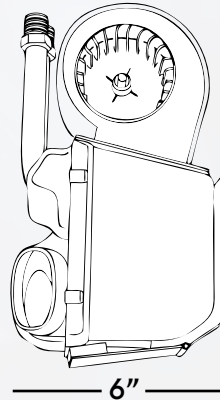

Side View

6"
10.25"



COMPAC HEATER SERIES

Has 200 CFM flow and 16,5000 BTU output.

Compact heater.

50515-VUH 150.00

Compact heater with defrost.

50615-VUH 199.00

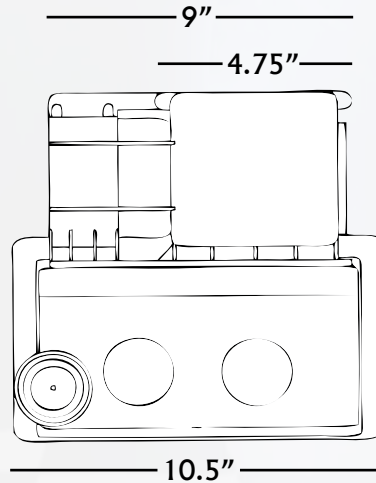
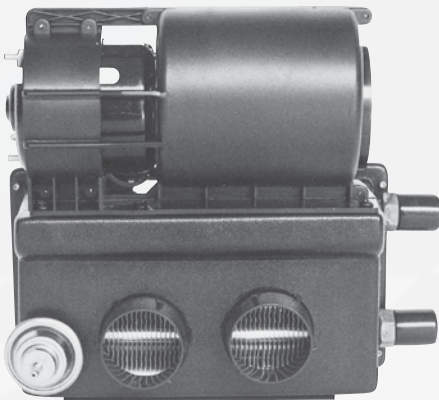

Front View

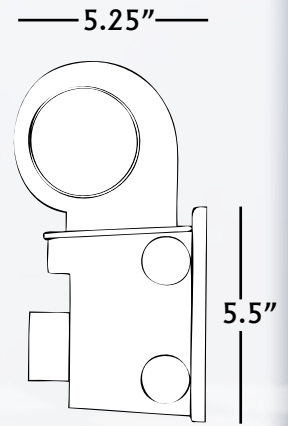

Side View

Defrost ducts



UNIVERSAL DEFROST DUCTS

6.5" x 3.25"

63375-VUE PAIR. 12.00



DIRECT FLOW DEFROST DUCTS

For 2" hose. 6.5" x 3.5"

63380-VUE PAIR. 12.00

ACCESSORY CONTROL PANELS



VERTICAL PROLINE PANEL
 2.375" wide x 4" tall - Internally lighted.
 Brushed aluminum
 49320-VUQ 119.00
 Black anodized
 49321-VUQ 134.00



Gen-II 4-Knob Underdash Pod - for Gen-II systems with servo heater valve - Standard
 49200-RHA 40.00

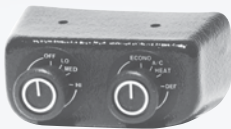

Cool Control with Wiring Harness
 49100-VUA 40.00
Heat & Cool Control with Harness
 49100-VUA 40.00
Heat, Cool, & Defrost Control with Harness
 49100-VUA 40.00

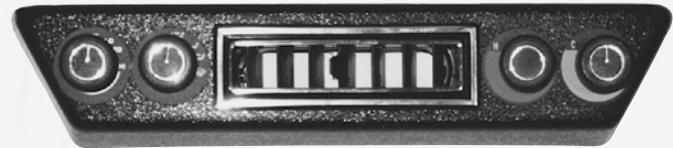

Gen-II 4-Knob Underdash pod with louver - for Gen-II systems with servo heater valve - Optional
 49205-RHA 40.00



PROLINE PANELS
 4.5" wide x 2" tall - Internally lighted.
 Brushed aluminum
 49120-VQU 119.00
 Black anodized
 49220-VUQ 134.00



STREAMLINE II PANEL
 4.23" wide x 2" tall - Internally lighted.
 49600-VUQ 119.00



STREAMLINE PRO-PANEL
 5.5" wide x 2.5" tall - Back lighted knobs.
 49500-VSQ 139.00



4-LEVER PROCAST FINGERTIP CONTROL PANEL
 Now you can have true OEM style louver air temperature regulation and bi-level operation of A/C and heat modes! This new panel uses our exclusive servo actuated heater valve which allows the introductions of small amounts of heat to regulate air temperature. Simplified installation with plug-in connections, no vacuum lines, and fewer wires to route. The face is slightly larger to allow you to upgrade from your existing Proline Panel installation. Both are internally lighted.
 4.63" wide x 2.44" tall
 49110-SHQ 40.00
 2.44" wide x 4.63" tall
 49321-SVQ 40.00





The COBRA advantage!

All Walker Radiators have the Cobra advantage. Cobra is manufactured from copper and brass. Copper has been and will be for the foreseeable future, the ultimate for heat transfer, long lasting durability and is repairable if needed.

NOT JUST A LOUVERED FIN. Cobra's fin is designed for maximum cooling efficiency. There are louvers at each fin crossing. These louvers are computer designed and manufactured to a precise angle and length. Their location and angle on each fin is designed to eliminate air boundary build-up (a layer of air that insulates fin material from air flow).



The distance between each tube (Fin height) is precisely 1/4". This 1/4" fin height measurement is unique in that it allows for the additional number of fins and tubes through Cobra's core area and is manufactured exclusively by Walker. Also, Cobra's fin height is computer controlled to give a uniform bond between the tube and fin area. This uniform bond is essential for maximum heat transfer and strength to withstand vibrations.

Cobra's fin count is 17 (Z-series 12), which means there are 17 heat transfer fins in every vertical inch of Cobra's core surface. This fin count is unmatched in number.

Cobra is also considerably thinner than other street rod radiators on the market. Its unique design requires less cubic inches for maximum cooling efficiency. This allows for additional fan clearance in the engine compartment.

Cobra's superior design and unsurpassed quality provides a cooling system required for today's high performance engines.

Things you should know about Walker Radiators



ALL TOP QUALITY MATERIAL

Complete with all connections

Ready to bolt to your application

Each assembly comes complete with the following standards:

Designed to operate with a 15 lb. to an 18 lb. cap.

Top tanks are stamped from .040 deep draw Brass.

Pre-drawn heavy (12 Ga.) steel rod holder with threaded holes for all attachments.

Brass drain cock for easy draining.

Oil cooler for automatic transmissions.

(Fitting size is 1/8" pip thread). Line fitting kits are available separately.

Heavy gauge steel side brackets.

Simple bolt in application.

No alterations to grill or grill shell needed.

Guaranteed to cool.

AIR CONDITION MODELS:

Condenser compatible for use with Freon R-12 and R-134a refrigerant.

Easy condenser to compressor-evaporator hook ups.

Condenser fitting sizes are #6 and #8 o-ring designs.

Securely mounted for long lasting durability.

Which Walker radiator is best suited for your application ?

Cobra Standard Series: Designed for basic small block engine applications that are stock throughout (not modified and not bored). Complete with pressure system and an oil cooler for your automatic transmission.

Cobra Standard Cool Mate Series: The same power as the Cobra Standard Series with transmission oil cooler, and air condition condenser for stock engine applications.

Cobra Z-Series: The ultimate in cooling system radiators. Born to cool the massive boss big block engines, this design radiator is a must for ultra heavy duty applications.

Cobra Z-Series Cool Mate Series: The same cooling power as the Z-Series with all the extras needed for modified air conditioned supplied engines.

NOTE: Modified engines must use the Z-Series radiators. The Cobra Standard Series radiators are **NOT DESIGNED TO COOL** any engine that has been **BORED**. Also big block Chevrolets, big block Fords®, Ford® flatheads, big block Mopars, 400 small block Chevrolets and anticipated hot running applications such as **SUPER CHARGED** engines required the **COBRA Z Series radiators**.





COBRA STANDARD SERIES RADIATORS

Cobra Standard Series: Designed for basic small block engine applications that are stock throughout (not modified and not bored). Complete with pressure system and an oil cooler for your automatic transmission.

Cobra Standard Series Radiators							Fan Shrouds
Year	Model	T.H.C.	B.H.C.	Note:	Without A/C \$574.15	With A/C \$716.50	\$85.00
1932	Pickup	Center	Right	xx //	C-512-1	C-Ac512-1	Ws-50
1934-36	Pickup & Panel	Center	Right	xx	C-518-1	C-Ac518-1	Ws-50
1937-38	Pickup & Panel	Center	Right	xx	C-516-1	C-Ac516-1	Ws-55A
1939-40	Pickup	Center	Right	xx	C-522-1	C-Ac522-1	Ws-55A
1940-41	GMC Pickup	Center	Right		C-529-1	C-Ac529-1	Ws-55A
1941-46	Pickup & Panel	Center	Right		C-507-1	C-Ac507-1	Ws-55A
1947-53	Pickup & Panel	Center	Right		C-520-1	C-Ac520-1	Ws-70
1954	Pickup & Panel	Center	Right		C-514-1	C-Ac514-1	Ws-70
1955-59	Pickup & Panel	Center	Right		C-519-1	C-Ac519-1	N/A

T.H.C. = Top hose connection
B.H.C. = Bottom hose connection

NOTE: xx = No dummer filler neck supplied
 // = Rear radiator shell support bracket must be altered

COBRA Z-Series RADIATORS

Cobra Z-Series: The ultimate in cooling system radiators. Born to cool the massive boss big block engines, this design radiator is a must for ultra heavy duty applications.

Modified (or BORED) engines must use the Z-Series radiators. Also big block Chevrolets, big block Fords®, Ford® flatheads, big block Mopars, 400 small block Chevrolets and anticipated hot running applications such as SUPER CHARGED engines required the COBRA Z Series radiators.

Cobra Z-Series Radiators							Fan Shrouds
Year	Model	T.H.C.	B.H.C.	Note:	Without A/C \$690.25	With A/C \$832.35	\$85.00
1932	Pickup	Center	Right	xx //	Z-512-1	Z-Ac512-1	Ws-50
1934-36	Pickup & Panel	Center	Right	xx	Z-518-1	Z-Ac518-1	Ws-50
1937-38	Pickup & Panel	Center	Right	xx	Z-516-1	Z-Ac516-1	Ws-55A
1939-40	Pickup	Center	Right	xx	Z-522-1	Z-Ac522-1	Ws-55A
1940-41	GMC Pickup	Center	Right		Z-529-1	Z-Ac529-1	Ws-55A
1941-46	Pickup & Panel	Center	Right		Z-507-1	Z-Ac507-1	Ws-55A
1947-53	Pickup & Panel	Center	Right		Z-520-1	Z-Ac520-1	Ws-70
1954	Pickup & Panel	Center	Right		Z-514-1	Z-Ac514-1	Ws-70
1955-59	Pickup & Panel	Center	Right		Z-519-1	Z-Ac519-1	N/A

T.H.C. = Top hose connection
B.H.C. = Bottom hose connection

NOTE: xx = No dummer filler neck supplied
 // = Rear radiator shell support bracket must be altered



Watson's StreetWorks

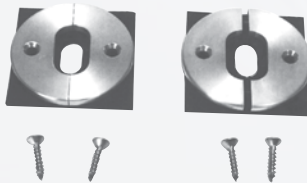

OVAL BRAKE & CLUTCH TRIM

For elongated or rectangular pedal shafts. Also trim the firewall for accelerator cable and kick down or for some TPI applications. 2 1/4" diameter. 5/8" by 1 1/8" hole. Solid machined part or our Split 'n' Pinned trim. Stainless steel screws. Rubber gasket.

- B02 (Solid) 15.95
- B02S (Split 'n' Pinned)..... 19.95

BILLET WIRE PORT

Dress up the firewall where the wiring harness goes through. Main body is 2" diameter by 1 1/2" inside diameter. Secures to the firewall with 4 truss head screws. A 1" by 1/32" deep cutout in the body allows the wire bundle to exit close to the firewall. Rubber grommet included for smaller wire bundles. Cover has 3 ball-milled grooves. Allows the wire bundle to be installed before the final attachment of the Wire Port. Overall height is 1 3/16". Attractive, functional and at a very reasonable price. Photo shows assembled Port to upper left and parts to lower right.

- B16 each 40.00

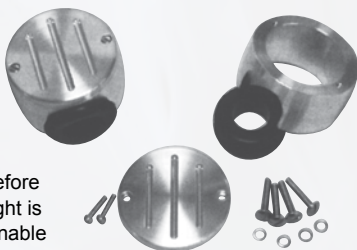

PASS THROUGH TRIM

For wire bundles, harnesses, cables, etc. Insulated rubber grommet with 5/8" inner diameter. Overall size is 2 1/4" outer diameter. Solid aluminum piece. Stainless steel screws

- B05 (solid) 15.95
- Split 'n' Pinned version that was designed specifically for use with the Howell Engineering TPI and TBI harnesses. Smaller #4 screws are closer to the outer edge to cover a hole up to 1 5/8" wide.
- B01ST (Split 'n' Pinned)..... 19.95

FLAMED TRIM NEAT NOBS

Hot Flames! Plates are 1 5/8" high by 4 1/4" long. Stainless screws. Choice of Smooth or Turned Nobs. Single door kits also available. Due to the plate width, their "remote" installation kit is required (except for use in suicide style doors) and is included in price shown, except where noted.

Small Bear Claw Latches not pictured.

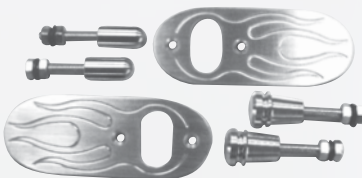

- B14FMS (Smooth Nobs w/o latches) 70.00
- B14FMT (Turned Nobs w/o latches) 70.00
- B14FMSL (Smooth Nobs w/ latches and strikers)..... 115.00
- B14FMTL (Turned Nobs w/ latches and strikers) 115.00
- B14FM-PLT (Flame Trim Plate only w/Screws, each) 20.00
- B14FMSX ("FMS" w/o remote install kit)..... 52.00
- B14FMTX ("FMT" w/o remote install kit) 52.00

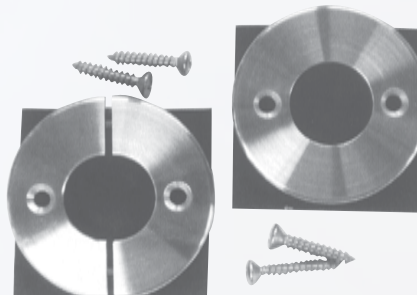

ROUND BRAKE & CLUTCH TRIM

For round pedal shafts. Fits floor dimmer switch. Use around wire, hoses, harnesses, etc. 2 1/4" diameter with a 1 5/16" diameter hole. Stainless steel screws. Rubber gasket (not in photo) Solid machined part our their Split 'n' Pinned.

- B01 (Solid) 15.95
- B01S (Split 'n' Pinned)..... 19.95

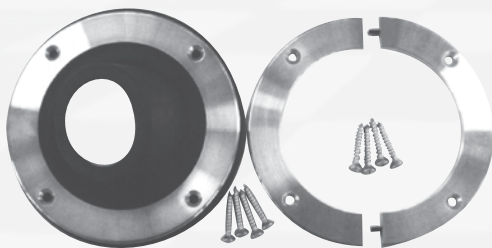

STEERING COLUMN TRIM

Easy install Split 'n' Pinned design - no column removal required. Ring is 3.420" inner diameter, 4.800" outer diameter. Stainless steel screws. Rubber seal has an opening to fit GM and other columns measuring 1 3/4" to approximately 2 1/8" diameter. (Trimming is required for larger diameters.)

- B03 each 35.00
- B03S (Rubber Seal Only) 20.00
- B03R (Aluminum Ring w/Screws, No Seal)..... 20.00

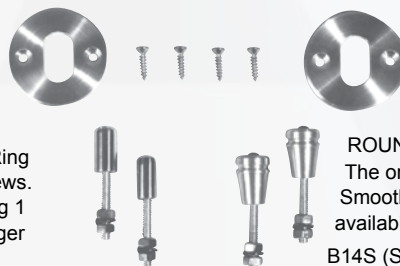

ROUND TRIM NEAT NOBS

The original round trim plate is 2 1/4" in diameter. Smooth or Turned Nobs. Single door kits also available.

- B14S (Smooth Nobs w/o latches) 44.95
- B14T (Turned Nobs w/o latches) 44.95
- B14SL (Smooth Nobs w/ latches and strikers) 89.95
- B14TL (Turned Nobs w/ latches and strikers) 89.95



Watson's StreetWorks



THE "Q" BILLET INTERIOR DOOR HANDLES
No Question about the Quality and they are

Quite attractive, too. StreetWorks "Q" makes Quick work of releasing bear claw or original handles with over 1" of pull travel. 3 1/8" wide 1 5/8" high by about 1/2" thick not including the "trigger". Blind fastened from the back. Two 4-foot "easy pull" cables, cable clips, compression sleeves and hardware included.

B18 pair99.00

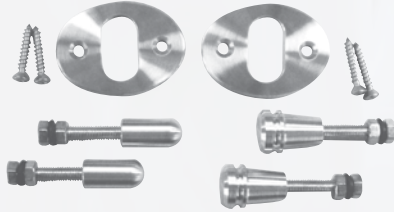

OVAL TRIM NEAT NOBS

The trend in interior design - oval. Plates are 1 5/8" high by 2 1/4". Smooth or Turned Nobs. Stainless screws. Single door kits also available.

- B14OVS (Smooth Nobs w/o latches) . . . 49.95
- B14OVT (Turned Nobs w/o latches) . . . 49.95
- B14OVSL (Smooth Nobs w/ latches and strikers) 94.95
- B14OVTL (Turned Nobs w/ latches and strikers) 94.95
- B14OV-PLT (Oval Trim Plate only w/Screws, each) 18.00

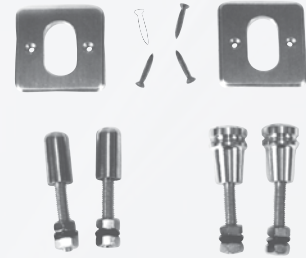

SQUARE TRIM NEAT NOBS

1 3/4" square trim plates. Match the look of billet power window switch plates. Smooth or Turned Nobs. Stainless screws. Single door kits also available.

- B14QS (Smooth Nobs w/o latches) 49.95
- B14QT (Turned Nobs w/o latches) 49.95
- B14QSL (Smooth Nobs w/ latches and strikers) 94.95
- B14QTL (Turned Nobs w/ latches and strikers) 94.95
- B14Q-PLT (Square Trim Plate only w/Screws, each) 18.00

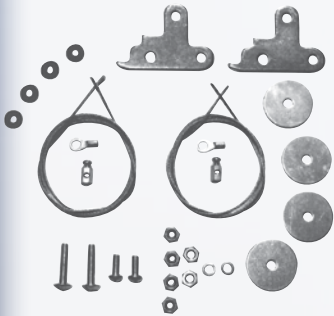

NEAT NOB REMOTE INSTALLATION KIT

Allows you to install StreetWorks Neat Nobs away from the latch and door jam, forward on the door. "T" lever bell crank and cable are used to attach to the latch. Same downward push on the nob trips the latch. Two 30" long cables. Works in either steel or fiberglass cars. All hardware included. Detailed drawing and instructions.

B14R (for 2 doors)..... 17.95



TILT SWITCH

Turns on lights in your glove box, trunk, or under-hood. When it tilts, the light comes on. 1/2" square x 1" long. Industrial adhesive for mounting.

- Tilt Switch only (1/2 amp max) 19.95
- L02 each 19.95
- Tilt switch with lamp/bracket. Screws & connectors for a ready-to-install Trunk/Hood kit L03 each 24.95



LED DUMMY LOAD

This "dummy load" wires in parallel with the LED to add the necessary amperage draw. One dummy load per side is usually sufficient.

L52DL each 3.50

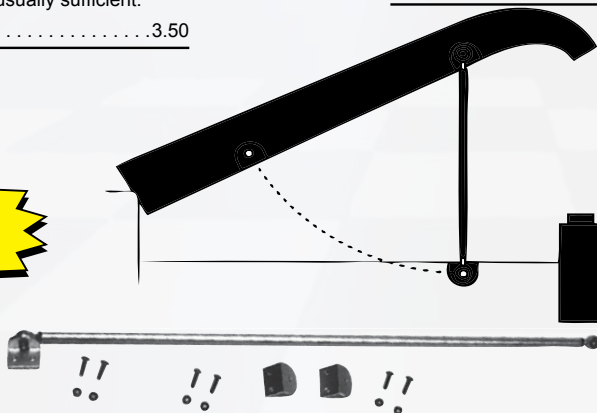

SOLID ROD HOOD PROP

For '37 and later models with one piece hoods but can be fitted to many applications. Aluminum rod and brackets. Stainless steel quick release pin and hardware. Positive locking in the up or down positions (wind proof). Attractive satin finish, approximately 24 3/4" center to center.

- B13 each 79.95
- B13SSQRP (Replacement Quick Release Pin) 20.00

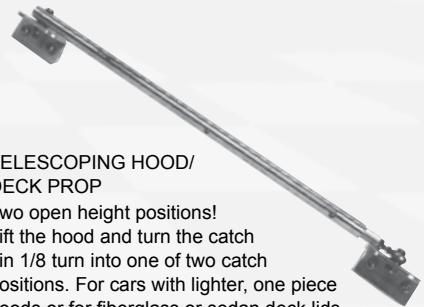

TELESCOPING HOOD/ DECK PROP

Two open height positions! Lift the hood and turn the catch pin 1/8 turn into one of two catch positions. For cars with lighter, one piece hoods or for fiberglass or sedan deck lids. Aluminum rod, tube and brackets. Stainless steel hardware Three position brackets. Threaded spherical rod end for adjustment. Firewall mount lower bracket. Approximately 14 1/2" long center to center when closed, 19 1/4" center to center half open and 24 1/4" center to center fully opened.

B13T each 79.95

Watson's StreetWorks

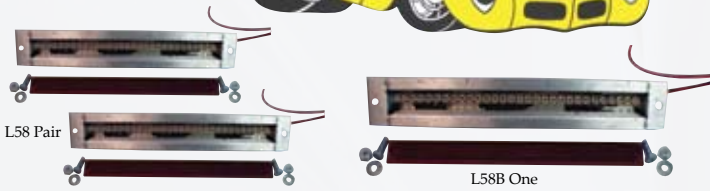

RECTANGULAR FLUSH MOUNT TAILLIGHTS OR 3RD BRAKE LIGHTS

60 Super Bright Red LED strips inside aluminum housings. 1/4" thick build-in, flush mounted red acrylic lenses with prismatic diffusers - can be fit into curved fenders, roll pans and pickup bed corners up to 1/4" for a seamless look (the acrylic lenses cannot be bent). Taillights have dual intensity for taillights and turn-brake lights. The 3rd Brake Light is single, full intensity. Need only 1" of clearance space behind the mounting surface. Weld-in or glass-in studs for mounting are included. Quality instructions. Lenses are only 1/2" wide by 15 1/4" long. Please note that these are build-in kits requiring body working skills.

Taillight Hot Slots L58 pair	195.00
3rd Brake Light Hot Slots L58B one	95.00
Need lenses for your own project? They include the shaped red lens and bonded clear diffuser.	
L58-LENS each	30.00

Please Note:

LED taillights are directional and must be mounted pointing straight back (horizontal). They also draw very little amperage, generating lots of light with very little heat, but may need an electronic flasher or dummy loads to work properly. Please call with any questions.



As installed - a beautiful flush mounted finish, paint-to-lens, clear coat to finish and seal.



SEQUENTIAL LED TAILLIGHTS!

A real attention getter! Their L58 taillights, but three steps better. Each light is split into three groups of 20 LED's that sequence inside-out with the turn signals. Brake lights quickly sequences once then all stay on. All the necessary converters and sequencing modules are included along with great instructions.

L58-SEQ each	299.00
------------------------	--------

3 groups of 20 LED's in each taillight sequence inside-out with the turn signals, once when the brakes are applied.

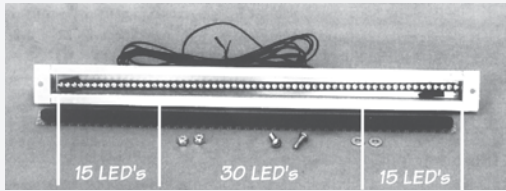

3RD BRAKE LIGHT WITH TURN SIGNALS

Same as L58B, but two steps better. 3 groups of 15-30-15 provide a 30 LED center 3rd brake light and two 15 LED turn signal/brake lights. Or add our LED Conversion Kits to get taillight and turn/brake or wire them all as one big and bright 3rd brake light.

L58BT each	130.00
----------------------	--------

With the turn signals off, all 60 LED's light up with the brake. If the right turn signal is on, the other 45 LED's are brake light, etc.



Note: These are small lights. More than one pair may be needed for your application.

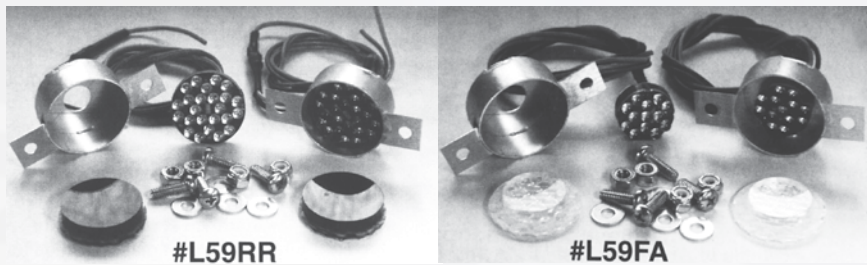

HOT DOTS! ROUND FLUSH MOUNT LED PARK AND TAILLIGHTS

Bright Round LED clusters fit inside aluminum housings. 1/4" thick build-in, flush mounted red acrylic lenses with prismatic diffusers - can be fit into curved fenders for the seamless look. All have dual intensity for taillights and turn-brake lights. Need only 1" of clearance space. Weld-in or glass-in studs for mounting are included. Quality instructions.

Taillight Hot Dots- Red Lens

1 1/4" diameter red lenses with diffusers! 1 1/4", 24 Red LED's per light.

L59-RR pair	110.00
-----------------------	--------

Taillight Hot Dots- Clear Lens

1 1/4" diameter clear lenses with diffusers! 1 1/4", 24 Red LED's per light.

L59-RCL pair	110.00
------------------------	--------

Small Park Light Hot Dots

1 5/16" diameter clear lenses/diffusers! 13 Amber LED's per light.

L59FA pair	110.00
----------------------	--------

Large Park Light Hot Dots

1 1/4" diameter clear lenses with diffusers! 1 1/4" 24 Amber LED's per light.

L59FALG pair (not shown)	110.00
------------------------------------	--------

These are really bright!



Watson's StreetWorks



CONSOLE PLATE POWER WINDOW SWITCH KIT

Billet 3-wire rocker switches inside an attractive Billet Console Plate that's 2 1/4" wide by 2 1/2" high with a brushed finish. Add distinct styling in Billet to your custom console. 2 switches,

Console Plate, 2 polarity reversing modules, wire leads, connectors and instructions.

L39BCD each (shown) 125.00

Note: These are not plug-in replacements for 5-wire switches. Call if you have any questions. Reversing modules are needed for power windows. Switches without modules will work for air-ride systems with separate up - down solenoids requiring a positive signal. Order:

L39BSX (single) 54.00

L39BDX (double) 93.00

Switches and Console Plate without modules for SPDT applications up to 5 amps max.

L39BCDX each 119.00



OVAL BILLET POWER WINDOW SWITCHES

Billet 3-wire rocker switch sits inside an oval Billet frame. Dual switch kit for center console mounting or for both switches on the driver door only. Dual switch frame is 3 1/8" wide by 1 5/8" high. Adapts directly to positive output frame, no additional relays required! 2 polarity reversing modules, wire leads, and instructions.

L39BOD each 125.00

Note: These are not plug-in replacements for 5-wire switches. Call if you have any questions. Reversing modules are needed for power windows. Switches without modules will work for air-ride systems with separate up - down solenoids requiring a positive signal. Order:

L39BOSX (single) 64.00

L39BODX (double) 119.00

Switches and Console Plate without modules.

L39BFSX (single) 64.00



FLAMED BILLET FRAME POWER WINDOW SWITCHES

Billet 3-wire rocker switch inside a flamed Billet frame that's 4 1/4" wide by 1 5/8" high. Adapts directly to positive output frame, no additional relays required!

Single switch and frame, polarity reversing module, wire leads, and instructions.

L39BFS each 70.00

Note: These are not plug-in replacements for 5-wire switches. Call if you have any questions. Reversing modules are needed for power windows. Switches without modules will work for air-ride systems with separate up - down solenoids requiring a positive signal. Order:

L39BSX (single) 54.00

L39BDX (double) 93.00

Switches and Console Plate without modules.

L39BFSX (single) 64.00



OVAL BILLET 4-SWITCH PANEL

4 of their Billet 3-wire rocker switches mounted in an oval Billet frame that's 4 7/8" wide by 1 5/8" high. Use as a driver door

control for power windows on a 4-door or

as a stand-alone console switch center. Note: This panel is sold without relays or polarity reversing module(s), so be sure to explain your needs our tech staff when you order. AT LEAST ONE ADDITIONAL REVERSING MODULE will be needed when using this panel with other of our Oval Billet Power Window Switches.

L39BO4X each 199.00



RECTANGULAR BILLET ALUMINUM POWER WINDOW SWITCHES

Billet 3-wire rocker switch sits inside a Billet frame that's only 1-1/8" wide by 1-3/4" high. Adapts directly to positive output frame, no additional relays required!

Single switch/frame, polarity reversing module, wire leads, and instructions.

L39BS each 60.00

Dual switch kit for center console mounting or for both switches on the driver door only. Dual switch frame is 2" wide by 1-3/4" high, 2 polarity reversing modules, wire leads, and instructions.

L39BD each 105.00

Triple kit puts dual switches on the driver door and one on the passenger door. Switch and frames, 2 polarity reversing modules, lots of wire, and instructions.

L39BT each 150.00

Note: These are not plug-in replacements for 5-wire switches. Call if you have any questions. Reversing modules are needed for power windows. Switches without modules will work for air-ride systems with separate up - down solenoids requiring a positive signal. Order:

L39BSX (single) 54.00

L39BSX (double) 93.00



ILLUMINATED BILLET 5-WIRE POWER WINDOW SWITCH KITS

Beautiful new Billet 5-wire rocker switch snaps into a rectangular billet frame that's only 1 1/4" wide by 2 5/16" high. The frame mounts with 2 blind studs from behind. Single switch with plug and frame, terminals, wire leads and instructions.

L39-5BS each 80.00

Dual switch kit for center console mounting or for both switches on the driver door only. Two Billet 5-wire rocker switches snap into a dual switch frame that is 2 1/4" wide by 2 5/16" high. The frame mounts with 4 blind studs from behind. 2 switches with plugs and dual frame, terminals, wire leads and instructions.

L39-5BD each 145.00

Triple kit puts dual switches on the driver door and one on the passenger door. 3 switches with plugs, 1 single frame, 1 dual frame, terminals, fuse holder, wire leads, cross-over wiring and instructions.

L39-5BT each (shown) 210.00

Here are some examples of how we measure.

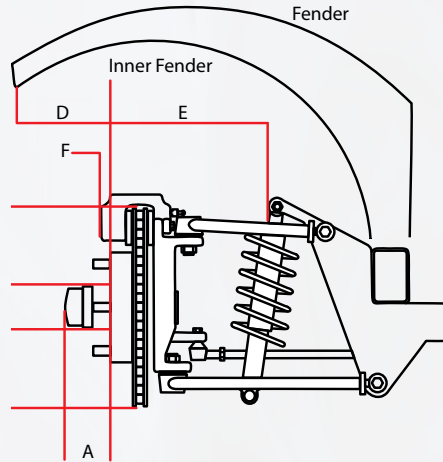

Front Wheel Section

- A- Hub Height
- B- Hub Diameter
- C- Rotor Diameter
- D- Inside Fender to Mounting Surface
- E- First Obstruction on Frame Side to Mounting Surface- Back Space
- F- Area of Caliper Past Mounting Surface

D + E = total distance available for wheel
 Subtract 2" for clearance

How to Measure Wheel Back

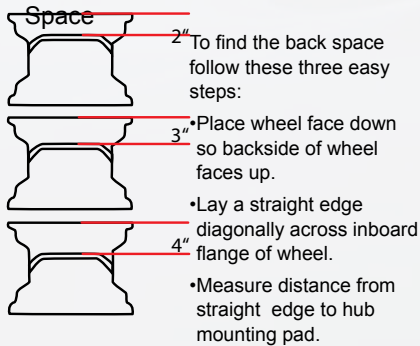
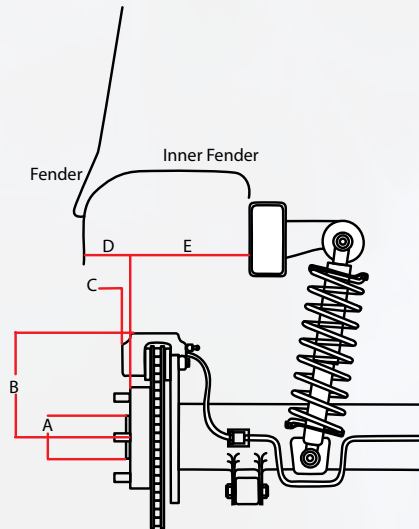

Diagram shows 2", 3", and 4" backspace.



Rear Wheel with Caliper

- A- Hub Height
- B- Hub Diameter
- C- Rotor Diameter
- D- Inside Fender to Mounting Surface
- E- First Obstruction on Frame Side to Mounting Surface - Back Space

D + E = total distance available for wheel
 Subtract 2" for clearance

How to Measure Bolt Patterns



4-Lug
 Measure from the middle of two bolts directly across from each other. This is the same for the 6 and 8 lug patterns as well.



5-Lug
 Measure from the back of one hole to the center of the second hole.

WHEEL VINTIQUES makes high quality wheels! They are **SPECIAL ORDER & NON-RETURNABLE**. Be 100% positive your information is correctly filled out on the **ORDER/CONFIRMATION FORM!!!**

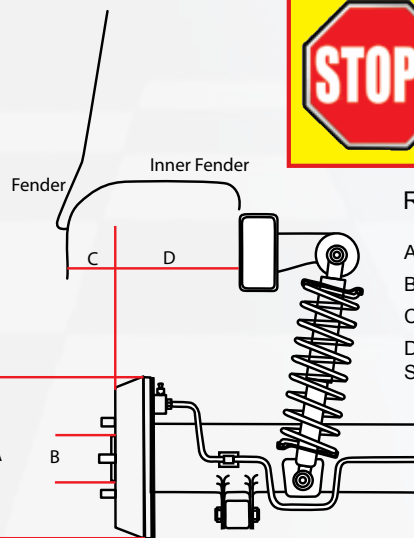

Rear Wheel without Caliper

- A- Drum Diameter
- B- Hub Diameter
- C- Inside Fender to Mounting Surface
- D- First Obstruction on Frame Side to Mounting Surface- Back Space

D + E = total distance available for wheel
 Subtract 2" for clearance



31 SERIES PICK-UP RALLEY - PRE '71 Chrome

Part #	Rim Size	Bolt Circle	Rear Spacing	Price
31-5606334	15 x 6	6-5 1/2	3-3/4	88.00
31-570604	15 x 7	6-5 1/2	4	94.00
31-580604	15 x 8	6-5 1/2	4	94.00
31-5006042	15 x 10	6-5 1/2	4 1/2	111.00
31-500605	15 x 10	6-5 1/2	5	111.00
31-51206042	15 x 12	6-5 1/2	4 1/2	166.00
31-51406042	15 x 14	6-5 1/2	4 1/2	188.00

Special Order - NON RETURNABLE

Shown with trim ring and #1012-A cap

- Accessories Available: 1000, 1002, 1004, 1006, 1008, 1012, 1012A, 1013, 1014 1015, 1016, 1017, 1018, 1019, 1020, 1025, 1026, 1039, 2030, 3000-15, 3001, 3001A, 3002 (see accessories in back pages)
- Singles, 5-4 3/4 bolt pattern
- O.E. Lug Nuts applicable
- Factory GM hubcaps applicable
- Factory GM Trim Rings applicable
- Hubcaps & Trim Rings not included
- Custom offsets are special order only and NON-Returnable



33 SERIES PICK-UP RALLEY - '71 Up Chrome

Part #	Rim Size	Bolt Circle	Rear Spacing	Price
33-5605334	15 x 6	5-5	3-3/4	82.00
33-570504	15 x 7	5-5	4	86.00
33-580504	15 x 8	5-5	4	89.00
33-5805042	15 x 8	5-5	4 1/2	89.00
33-580505	15 x 8	5-5	5	89.00
33-5005044	15 x 10	5-5	4 1/4	113.00
33-5005042	15 x 10	5-5	4 1/2	113.00
33-500505	15 x 10	5-5	5	113.00

Special Order - NON RETURNABLE

Shown with trim ring and #1039 cap

- Accessories Available: 1000, 1002, 1004, 1006, 1008, 1012, 1012A, 1013, 1014 1015, 1016, 1017, 1018, 1019, 1020, 1025, 1026, 1039, 2030 (see accessories in back pages)
- Full Chrome
- O.E. Lug Nuts applicable
- Factory GM hubcaps applicable
- Hubcaps not included
- Custom offsets are special order only and NON-Returnable



35 SERIES Pick-up Rallye - Pre '71 Silver

Part #	Rim Size	Bolt Circle	Rear Spacing	Price
35-5606334	15 x 6	6-5 1/2	3-3/4	65.00
35-570604	15 x 7	6-5 1/2	4	70.00
35-580604	15 x 8	6-5 1/2	4	76.00
35-5006042	15 x 10	6-5 1/2	4 1/2	81.00
35-500605	15 x 10	6-5 1/2	5	81.00
35-51206042	15 x 12	6-5 1/2	4 1/2	134.00
35-51406042	15 x 14	6-5 1/2	4 1/2	145.00

Special Order - NON RETURNABLE

Shown with trim ring and #1012-A cap

- Accessories Available: 1000, 1002, 1004, 1006, 1008, 1012, 1012A, 1013, 1014 1015, 1016, 1017, 1018, 1019, 1020, 1025, 1026, 1039, 2030, 3000-15, 3002A, 3005-15, 3006A (see accessories in back pages)
- O.E. Lug Nuts applicable
- Hubcaps & Trim Rings not included
- Custom offsets are special order only and NON-Returnable



37 SERIES Pick-up Rallye - '71 up Silver

Part #	Rim Size	Bolt Circle	Rear Spacing	Price
37-5606334	15 x 6	5-5	3-3/4	65.00
37-570504	15 x 7	5-5	4	70.00
37-580504	15 x 8	5-5	4	73.00
37-580505	15 x 8	5-5	5	73.00
37-5005042	15 x 10	5-5	4 1/2	81.00
37-500505	15 x 10	5-5	5	81.00
37-51205042	15 x 12	5-5	4 1/2	134.00

Special Order - NON RETURNABLE

Shown with trim ring and #1012-A cap

- Accessories Available: 1000, 1002, 1004, 1006, 1008, 1012, 1012A, 1013, 1014 1015, 1016, 1017, 1018, 1019, 1020, 1025, 1026, 1039, 2030, 3000-15, 3002A, 3005-15, 3006-15 (see accessories in back pages)
- O.E. Lug Nuts applicable
- Bare steel deduct \$5.00
- Factory GM hubcaps applicable
- Hubcaps & Trim Rings not included
- Custom offsets are special order only and NON-Returnable



WHEEL VINTIQUES makes high quality wheels! They are **SPECIAL ORDER & NON-RETURNABLE**. Be 100% positive your information is correctly filled out on the **ORDER/CONFIRMATION FORM!!!**

66 SERIES Chevy Style Rallye - Silver

Part #	Rim Size	Bolt Circle	Rear Spacing	Price
66-660504	16 x 6	5-5	4	80.00
66-660604	16 x 6	6 - 5 1/2	4	80.00
66-670504	16 x 7	5-5	4	92.00
66-670604	16 x 7	6 - 5 1/2	4	92.00
66-6805042	16 x 8	5-5	4 1/2	101.00
66-680604	16 x 8	6 - 5 1/2	4	101.00
66-600505	16 x 10	5-5	5	138.00
66-600605	16 x 10	6 - 5 1/2	5	138.00
66-7705042	17 x 7	5-5	4 1/2	138.00
66-7706042	17 x 7	6 - 5 1/2	6 - 5 1/2	138.00
66-7805042	17 x 8	5-5	4 1/2	197.00
66-7806042	17 x 8	6 - 5 1/2	4 1/2	197.00
66-790505	17 x 9	5-5	5	218.00
66-790605	17 x 9	6 - 5 1/2	5	218.00



WHEEL VINTIQUES makes high quality wheels! They are SPECIAL ORDER & NON-RETURNABLE. Be 100% positive your information is correctly filled out on the ORDER/CONFIRMATION FORM!!!

- Accessories Available: 1000, 1002, 1004, 1006, 1008, 1012, 1012a, 1013, 1014, 1015, 1016, 1018, 1019, 1020, 1025, 1026, 3005, 3006 (see accessories in back pages)
- Bare steel available
- . Lug Nuts applicable
- Hubcaps & trim rings not included

68 SERIES Chevy Style Rallye - Chrome

Part #	Rim Size	Bolt Circle	Rear Spacing	Price
68-660504	16 x 6	5-5	4	105.00
68-660604	16 x 6	6 - 5 1/2	4	105.00
68-670504	16 x 7	5-5	4	115.00
68-670604	16 x 7	6 - 5 1/2	4	115.00
68-6805042	16 x 8	5-5	4 1/2	122.00
68-680604	16 x 8	6 - 5 1/2	4	122.00
68-600505	16 x 10	5-5	5	159.00
68-600605	16 x 10	6 - 5 1/2	5	159.00
68-7705042	17 x 7	5-5	4 1/2	264.00
68-7706042	17 x 7	6 - 5 1/2	6 - 5 1/2	264.00
68-7805042	17 x 8	5-5	4 1/2	264.00
68-7806042	17 x 8	6 - 5 1/2	4 1/2	264.00



- Accessories Available: 1000, 1002, 1004, 1006, 1008, 1012, 1012a, 1013, 1014, 1015, 1016, 1018, 1019, 1020, 1025, 1026, 3005, 3006 (see accessories in back pages)
- Full Chrome (Reverse Chrome extra cost option)
- O.E. Lug Nuts applicable
- Hubcaps & trim rings not included
- OE GM hubcaps styles applicable



CHEVY POLICE CAP
 Chrome Plated
 Fits:
 • 14" & 15" Smoothie
 • Pick-up Rallye pre '71
1001C each 26.50



1952 CHEVY CAP
 Stainless Steel
 Fits:
 • Pickup Rallye (5 & 6 lug)
 • 16" & 17" Rallye & Smoothie
1004 each 32.95

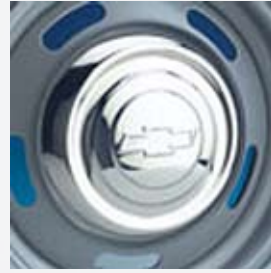

1952 CHEVY CAP
 Stainless Steel
 Fits:
 • 14" & 15" Smoothie
1005 each 32.95



1956 CHEVY CAP
 Stainless Steel
 Fits:
 • Pickup Rallye (5 & 6 lug)
 • 16" & 17" Rallye & Smoothie
1006 each 34.00



BABY MOON CAP
 Stainless Steel
 Fits:
 • Pickup Rallye (5 & 6 lug)
 • 16" & 17" Rallye & Smoothie
1008 each 16.00



DERBY CAP O.E. STYLE
 Fits:
 • Pickup Rallye (5 & 6 lug)
 • 16" & 17" Rallye & Smoothie
 • O.E.M. Script
1012 each 51.00



DERBY CAP with BOWTIE
 Fits:
 • Pickup Rallye (5 & 6 lug)
 • 16" & 17" Rallye & Smoothie
 • O.E.M. Script
1012A each 49.00



**DERBY CAP - Plastic
 No Script - Plain**
 Fits:
 • Pickup Rallye (5 & 6 lug)
 • 16" & 17" Rallye & Smoothie
 • O.E.M. Script
1013 each 22.00



DISC BRAKE CAP
 Chrome over Stainless
 Fits:
 • Pickup Rallye (5 & 6 lug)
 • 16" & 17" Rallye & Smoothie
 • O.E.M. Script
1015 each 34.00



**SHORT DERBY CAP
 Chrome**
 Fits:
 • Pickup Rallye (5 & 6 lug)
 • 16" & 17" Rallye & Smoothie
 • O.E.M. Script
1016 each 38.00



**1936 CHEVY CAP
 Chrome**
 Fits:
 • Pickup Rallye (5 & 6 lug)
 • 16" & 17" Rallye & Smoothie
1017 each 28.00



**1949 CHEVY CAP
 Chrome**
 Fits:
 • Pickup Rallye (5 & 6 lug)
 • 16" & 17" Rallye & Smoothie
1039 each 34.00



O.E. CHEVY STYLE CAP
 Chrome Plated
 • OEM Factory Wheels with
 outside knob
 • 10 1/8" diameter
1041 each 32.00

**1947-53 CHEVY CAP
 Chrome**
 Fits:
 • 16" & 17" Rallye & Smoothie
2030 each 43.00





THIS ORDER FORM IS SPECIFICALLY FOR WHEEL VINTIQUES WHEEL ITEMS ONLY. Please be 100% accurate when filling out this form as these wheels are special order and are therefore NON-RETURNABLE! PLEASE DO NOT SIGN THIS FORM UNTIL YOU HAVE LOOKED OVER YOUR ORDER.

Please print clearly and supply complete information. We must have a street address for accurate delivery. All orders will be shipped via FedEx, USPS or Motorfreight depending on costs and/or your request.

SOLD TO:

Name: _____
 Address: _____
 City: _____ State: _____
 Zip Code: _____ Phone: _____
 Vehicle Model & Year: _____
 E-mail address: _____

Toll Free (1-800-354-4040)
24 Hour Fax Ordering (1-405-631-5999)
Local (1-405-631-4400)
Monday thru Friday 8 a.m. to 5 p.m.
& Saturday 8 a.m. to 12 p.m.
Website www.ClassicChevroletParts.com

METHOD OF PAYMENT - Please indicate your Choice

Personal Check Cashiers Check Money Order

Sorry, NO credit cards on special order wheels.

SHIP TO: (if different from above)

Name: _____
 Address: _____
 City: _____ State: _____
 Zip Code: _____ Phone: _____

NOTE: THIS FORM IS FOR WHEEL VINTIQUES WHEEL ORDERS ONLY!!!

Order Qty.	Part #	Rim Size	Bolt Pattern	Wheel Back Space	Center Bore	Suggested Application	Price

HOW SHALL WE SHIP:
 FEDEX
 PARCEL POST

Freight averages at \$15.00 per wheel.
*****Please note that this price is subject to change.*****

Subtotal	
Shipping	
Insurance	
Okla. Sales Tax 8.375%	
Total	

Classic Chevrolet Parts Inc. 8723 S. I-35 Oklahoma City, OK 73149



Signature _____

(MUST BE SIGNED BEFORE ANY WHEELS WILL BE SHIPPED!)

Classic Chevrolet PARTS, Inc.

SUPPLIER OF QUALITY Chevrolet & GMC PARTS

Please print clearly and supply complete information. We must have a street address for FedEx or Motorfreight Delivery. They will not deliver to a P.O. Box. All orders will be shipped FedEx unless otherwise specified by you, the customer.

SOLD TO:

Name: _____
 Address: _____
 City: _____ State: _____
 Zip Code: _____ Phone: _____
 E-mail Address: _____

SHIP TO: (if different from above)

Name: _____
 Address: _____
 City: _____ State: _____
 Zip Code: _____ Phone: _____

EFFECTIVE 2006

Order Toll Free (800) 354-4040
 24 Hour Fax Ordering (405) 631-5999
 Customer Service / Parts Department (405) 631-4400
 www.ClassicChevroletParts.com
 Monday-Friday 8 a.m. to 5 p.m. & Saturday 8 a.m. to 12 p.m. (CST)

METHOD OF PAYMENT - Please indicate your Choice

Personal Check Cashiers Check Money Order

VISA MASTERCARD DISCOVER

(If using credit card please fill out the following information)

Name on Card: _____

Signature: _____

Account Number: (_____ / _____ / _____ / _____)

Expiration Date: ____/____/____ V-Code (located on back of card) _____

Vehicle: _____

Year _____ Make _____

Order Qty	Part Number	Description	Item Price	Item Total
Example	BK-5000	Shop Manual	0	0

HOW SHALL WE SHIP:
 FED-EX AIR US MAIL
 TRUCK LINE

*Refer to the Back Side of this Order Form for Shipping Charges and Additional Info.
 Min. Shipping Charge \$9.99
 (Tax applicable to Okla. residents ONLY)*

Subtotal	
Shipping	
Insurance	
Okla. Sales Tax 8.375%	
Total	

ORDERING INFORMATION:

To Order By Mail:

We honor Personal Checks, Cashier's Checks, Money Orders, Discover, Visa, and MasterCard on any mail order. It is our goal to ship within 48 hours of receipt of your order. If we are out of stock on any item and hold your backorder until the part arrives for shipment. If the backorder extends over 30 days, we will notify you when the part arrives and request that you reorder (The exception to this is if you prepaid the order with a check or money order. In this instance the part will automatically be shipped upon arrival).

To Order By Telephone:

If you have your order ready, with part numbers in hand, please call out Toll Free Order Desk 1-800-354-4040. Our operators will gladly take your order. You can place your order on your **Discover, Visa, and MasterCard**. Again, please feel free to use our convenient Toll Free order lines for placing your order – but you must have your information ready. If you need technical assistance or do not have your part numbers, please call our parts department (405) 631-4400. Our parts team will assist you with any of your needs. We are open Monday thru Friday 8 a.m. to 5 p.m. and Saturday 8 a.m. to 12 p.m. (CST).

Shipping Charges:

All Fed Ex Ground Shipments within the continental United States will be charged according to the S&H chart below. Air shipments will be quoted upon ordering. All orders out of the United States quoted upon ordering. All orders too large to ship Fed Ex or USPS will be shipped Motor Freight. Consult with your salesperson for Motor Freight quotations at the time of placing your order. Heavy or Bulk items will require additional shipping charges. Hawaii, Alaska, Puerto Rico will be shipped Fed Ex 2nd Day Air.

Air Shipping Services:

Next Day Air, Second Day Air, and Third Day Select Shipping Charges are available on any order. Federal Express is currently our primary shipping source. For other shipping options consult with your Salesperson when ordering.

Return Information:

30-Day Return Policy. Inspect your order immediately upon arrival. Be sure you have received the parts you ordered and that they are free of any manufacturing defects. If there is a problem please call us at (405) 631-4400 for instructions. **All returned parts must have a letter of explanation of problem, and a copy of the invoice must accompany merchandise.** If possible, please include a daytime phone number in case we need to contact for further questions. **ALL FREIGHT MUST BE PREPAID.** We cannot accept COD's. If the reasons for the return is due our error, please include receipts of your cost for shipping back to us, so we may reimburse you for the freight. If a refund is requested and the reason of error is NOT due to our negligence a 20% restocking fee will be applied. The restocking fee is not applicable to In-Store credit or exchanges. We will not refund on any wood products, electrical items or special order items. No refunds will be accepted after 30 days from the date of the invoice. **IF YOU NEED ASSISTANCE WITH A RETURN PLEASE CALL OUR PARTS DEPARTMENT AT (405) 631-4400**, so we may assist you. Shipping costs are non-refundable.

Merchandise Damages and/or Shortages:

Inspect your order immediately upon arrival. If you should receive parts that are freight damaged or missing due to a broken box, contact the carrier that delivered the merchandise immediately (i.e. Fed Ex, Post Office, Freight Line etc.) All damaged and/or broken carton merchandise, must be held in the **ORIGINAL** container for inspection by the carrier. If Fed Ex shipped it, contact them for an inspection. If delivered by Motor Freight, count all cartons before signing for delivery and note any discrepancies on the bill of lading with your signature. **DO NOT RETURN DAMAGED MERCHANDISE TO US!!** The delivering carrier is responsible for any damages committed while your parts were in transit. If you should find a shortage in your box not due to broken or damaged delivery you **MUST** notify our parts department at (405) 631-4400 within 72 hours of receipt. We only accept responsibility for shortages reported within a 72-hour grace period. We will do everything possible to see that your claim, and/or shortage is taken care of as fast as possible.

Refused Shipments:

Customers will be responsible for all shipping charges, storage fees and a 20% handling fee on all refused shipments. Merchandise refused that is not defective or damaged is subject to 20% restocking fee.

Prices:

We attempt to maintain all published prices as seen in the catalog, but due to the fact that we buy from hundreds of direct manufacturer, we can not control all product costs. If the supplier goes up, we are forced to raise our prices also. Consequently, our retail prices do change periodically and without notice. Please feel free to call for confirmation on current pricing.

Mailing List:

We maintain a mailing list by our sales history. If you are an active customer, you should be receiving periodic sales fliers and new item updates. The phone number you give us on your initial order will be used as your customer account number. If this number changes or you move, please send us a change of address form or call us so we may keep your current on our mailing list. We do not distribute your address, phone number or E-Mail address to outside sources.

GROUND SHIPPING & HANDLING CHART (Inside Continental U.S.A. - exc. Hawaii, Alaska, Puerto Rico)

Orders up to \$40.00 - add \$9.99	\$100.01 to \$300.00 -add 10%
\$40.01 to \$100.00 - add \$10.99	\$300.01 to \$500.00 -add 9%
	\$500.01 to \$800.00 -add 8%
	\$800.01 - UP -add 7%

Foreign Handling (per order) add \$20.00

Classic Chevrolet PARTS, Inc.

SUPPLIER OF QUALITY Chevrolet & GMC PARTS

Please print clearly and supply complete information. We must have a street address for FedEx or Motorfreight Delivery. They will not deliver to a P.O. Box. All orders will be shipped FedEx unless otherwise specified by you, the customer.

SOLD TO:

Name: _____
 Address: _____
 City: _____ State: _____
 Zip Code: _____ Phone: _____
 E-mail Address: _____

SHIP TO: (if different from above)

Name: _____
 Address: _____
 City: _____ State: _____
 Zip Code: _____ Phone: _____

EFFECTIVE 2006

Order Toll Free (800) 354-4040
 24 Hour Fax Ordering (405) 631-5999
 Customer Service / Parts Department (405) 631-4400
 www.ClassicChevroletParts.com
 Monday-Friday 8 a.m. to 5 p.m. & Saturday 8 a.m. to 12 p.m. (CST)

METHOD OF PAYMENT - Please indicate your Choice

Personal Check Cashiers Check Money Order

VISA MASTERCARD DISCOVER

(If using credit card please fill out the following information)

Name on Card: _____

Signature: _____

Account Number: (_____ / _____ / _____ / _____)

Expiration Date: ____/____ V-Code (located on back of card) _____

Vehicle: _____

Year _____ Make _____

Order Qty	Part Number	Description	Item Price	Item Total
Example	BK-5000	Shop Manual	0	0

HOW SHALL WE SHIP:
 FED-EX AIR US MAIL
 TRUCK LINE

*Refer to the Back Side of this Order Form for Shipping Charges and Additional Info.
 Min. Shipping Charge \$9.99
 (Tax applicable to Okla. residents ONLY)*

Subtotal	
Shipping	
Insurance	
Okla. Sales Tax 8.375%	
Total	

ORDERING INFORMATION:

To Order By Mail:

We honor Personal Checks, Cashier's Checks, Money Orders, Discover, Visa, and MasterCard on any mail order. It is our goal to ship within 48 hours of receipt of your order. If we are out of stock on any item and hold your backorder until the part arrives for shipment. If the backorder extends over 30 days, we will notify you when the part arrives and request that you reorder (The exception to this is if you prepaid the order with a check or money order. In this instance the part will automatically be shipped upon arrival).

To Order By Telephone:

If you have your order ready, with part numbers in hand, please call out Toll Free Order Desk 1-800-354-4040. Our operators will gladly take your order. You can place your order on your **Discover, Visa, and MasterCard**. Again, please feel free to use our convenient Toll Free order lines for placing your order – but you must have your information ready. If you need technical assistance or do not have your part numbers, please call our parts department (405) 631-4400. Our parts team will assist you with any of your needs. We are open Monday thru Friday 8 a.m. to 5 p.m. and Saturday 8 a.m. to 12 p.m. (CST).

Shipping Charges:

All Fed Ex Ground Shipments within the continental United States will be charged according to the S&H chart below. Air shipments will be quoted upon ordering. All orders out of the United States quoted upon ordering. All orders too large to ship Fed Ex or USPS will be shipped Motor Freight. Consult with your salesperson for Motor Freight quotations at the time of placing your order. Heavy or Bulk items will require additional shipping charges. Hawaii, Alaska, Puerto Rico will be shipped Fed Ex 2nd Day Air.

Air Shipping Services:

Next Day Air, Second Day Air, and Third Day Select Shipping Charges are available on any order. Federal Express is currently our primary shipping source. For other shipping options consult with your Salesperson when ordering.

Return Information:

30-Day Return Policy. Inspect your order immediately upon arrival. Be sure you have received the parts you ordered and that they are free of any manufacturing defects. If there is a problem please call us at (405) 631-4400 for instructions. **All returned parts must have a letter of explanation of problem, and a copy of the invoice must accompany merchandise.** If possible, please include a daytime phone number in case we need to contact for further questions. **ALL FREIGHT MUST BE PREPAID.** We cannot accept COD's. If the reasons for the return is due our error, please include receipts of your cost for shipping back to us, so we may reimburse you for the freight. If a refund is requested and the reason of error is NOT due to our negligence a 20% restocking fee will be applied. The restocking fee is not applicable to In-Store credit or exchanges. We will not refund on any wood products, electrical items or special order items. No refunds will be accepted after 30 days from the date of the invoice. **IF YOU NEED ASSISTANCE WITH A RETURN PLEASE CALL OUR PARTS DEPARTMENT AT (405) 631-4400**, so we may assist you. Shipping costs are non-refundable.

Merchandise Damages and/or Shortages:

Inspect your order immediately upon arrival. If you should receive parts that are freight damaged or missing due to a broken box, contact the carrier that delivered the merchandise immediately (i.e. Fed Ex, Post Office, Freight Line etc.) All damaged and/or broken carton merchandise, must be held in the **ORIGINAL** container for inspection by the carrier. If Fed Ex shipped it, contact them for an inspection. If delivered by Motor Freight, count all cartons before signing for delivery and note any discrepancies on the bill of lading with your signature. **DO NOT RETURN DAMAGED MERCHANDISE TO US!!** The delivering carrier is responsible for any damages committed while your parts were in transit. If you should find a shortage in your box not due to broken or damaged delivery you **MUST** notify our parts department at (405) 631-4400 within 72 hours of receipt. We only accept responsibility for shortages reported within a 72-hour grace period. We will do everything possible to see that your claim, and/or shortage is taken care of as fast as possible.

Refused Shipments:

Customers will be responsible for all shipping charges, storage fees and a 20% handling fee on all refused shipments. Merchandise refused that is not defective or damaged is subject to 20% restocking fee.

Prices:

We attempt to maintain all published prices as seen in the catalog, but due to the fact that we buy from hundreds of direct manufacturer, we can not control all product costs. If the supplier goes up, we are forced to raise our prices also. Consequently, our retail prices do change periodically and without notice. Please feel free to call for confirmation on current pricing.

Mailing List:

We maintain a mailing list by our sales history. If you are an active customer, you should be receiving periodic sales fliers and new item updates. The phone number you give us on your initial order will be used as your customer account number. If this number changes or you move, please send us a change of address form or call us so we may keep your current on our mailing list. We do not distribute your address, phone number or E-Mail address to outside sources.

GROUND SHIPPING & HANDLING CHART (Inside Continental U.S.A. - exc. Hawaii, Alaska, Puerto Rico)

Orders up to \$40.00 - add \$9.99	\$100.01 to \$300.00 -add 10%
\$40.01 to \$100.00 - add \$10.99	\$300.01 to \$500.00 -add 9%
	\$500.01 to \$800.00 -add 8%
	\$800.01 - UP -add 7%

Foreign Handling (per order) add \$20.00

Classic Chevrolet PARTS, Inc.

SUPPLIER OF QUALITY Chevrolet & GMC PARTS

Please print clearly and supply complete information. We must have a street address for FedEx or Motorfreight Delivery. They will not deliver to a P.O. Box. All orders will be shipped FedEx unless otherwise specified by you, the customer.

SOLD TO:

Name: _____
 Address: _____
 City: _____ State: _____
 Zip Code: _____ Phone: _____
 E-mail Address: _____

SHIP TO: (if different from above)

Name: _____
 Address: _____
 City: _____ State: _____
 Zip Code: _____ Phone: _____

EFFECTIVE 2006

Order Toll Free (800) 354-4040
 24 Hour Fax Ordering (405) 631-5999
 Customer Service / Parts Department (405) 631-4400
 www.ClassicChevroletParts.com
 Monday-Friday 8 a.m. to 5 p.m. & Saturday 8 a.m. to 12 p.m. (CST)

METHOD OF PAYMENT - Please indicate your Choice

Personal Check Cashiers Check Money Order

VISA MASTERCARD DISCOVER

(If using credit card please fill out the following information)

Name on Card: _____

Signature: _____

Account Number: (_____ / _____ / _____ / _____)

Expiration Date: ____/____/____ V-Code (located on back of card) _____

Vehicle: _____

Year _____ Make _____

Order Qty	Part Number	Description	Item Price	Item Total
Example	BK-5000	Shop Manual	0	0

HOW SHALL WE SHIP:
 FED-EX AIR US MAIL
 TRUCK LINE

*Refer to the Back Side of this Order Form for Shipping Charges and Additional Info.
 Min. Shipping Charge \$9.99
 (Tax applicable to Okla. residents ONLY)*

Subtotal	
Shipping	
Insurance	
Okla. Sales Tax 8.375%	
Total	

ORDERING INFORMATION:

To Order By Mail:

We honor Personal Checks, Cashier's Checks, Money Orders, Discover, Visa, and MasterCard on any mail order. It is our goal to ship within 48 hours of receipt of your order. If we are out of stock on any item and hold your backorder until the part arrives for shipment. If the backorder extends over 30 days, we will notify you when the part arrives and request that you reorder (The exception to this is if you prepaid the order with a check or money order. In this instance the part will automatically be shipped upon arrival).

To Order By Telephone:

If you have your order ready, with part numbers in hand, please call out Toll Free Order Desk 1-800-354-4040. Our operators will gladly take your order. You can place your order on your **Discover, Visa, and MasterCard**. Again, please feel free to use our convenient Toll Free order lines for placing your order – but you must have your information ready. If you need technical assistance or do not have your part numbers, please call our parts department (405) 631-4400. Our parts team will assist you with any of your needs. We are open Monday thru Friday 8 a.m. to 5 p.m. and Saturday 8 a.m. to 12 p.m. (CST).

Shipping Charges:

All Fed Ex Ground Shipments within the continental United States will be charged according to the S&H chart below. Air shipments will be quoted upon ordering. All orders out of the United States quoted upon ordering. All orders too large to ship Fed Ex or USPS will be shipped Motor Freight. Consult with your salesperson for Motor Freight quotations at the time of placing your order. Heavy or Bulk items will require additional shipping charges. Hawaii, Alaska, Puerto Rico will be shipped Fed Ex 2nd Day Air.

Air Shipping Services:

Next Day Air, Second Day Air, and Third Day Select Shipping Charges are available on any order. Federal Express is currently our primary shipping source. For other shipping options consult with your Salesperson when ordering.

Return Information:

30-Day Return Policy. Inspect your order immediately upon arrival. Be sure you have received the parts you ordered and that they are free of any manufacturing defects. If there is a problem please call us at (405) 631-4400 for instructions. **All returned parts must have a letter of explanation of problem, and a copy of the invoice must accompany merchandise.** If possible, please include a daytime phone number in case we need to contact for further questions. **ALL FREIGHT MUST BE PREPAID.** We cannot accept COD's. If the reasons for the return is due our error, please include receipts of your cost for shipping back to us, so we may reimburse you for the freight. If a refund is requested and the reason of error is NOT due to our negligence a 20% restocking fee will be applied. The restocking fee is not applicable to In-Store credit or exchanges. We will not refund on any wood products, electrical items or special order items. No refunds will be accepted after 30 days from the date of the invoice. **IF YOU NEED ASSISTANCE WITH A RETURN PLEASE CALL OUR PARTS DEPARTMENT AT (405) 631-4400**, so we may assist you. Shipping costs are non-refundable.

Merchandise Damages and/or Shortages:

Inspect your order immediately upon arrival. If you should receive parts that are freight damaged or missing due to a broken box, contact the carrier that delivered the merchandise immediately (i.e. Fed Ex, Post Office, Freight Line etc.) All damaged and/or broken carton merchandise, must be held in the **ORIGINAL** container for inspection by the carrier. If Fed Ex shipped it, contact them for an inspection. If delivered by Motor Freight, count all cartons before signing for delivery and note any discrepancies on the bill of lading with your signature. **DO NOT RETURN DAMAGED MERCHANDISE TO US!!** The delivering carrier is responsible for any damages committed while your parts were in transit. If you should find a shortage in your box not due to broken or damaged delivery you **MUST** notify our parts department at (405) 631-4400 within 72 hours of receipt. We only accept responsibility for shortages reported within a 72-hour grace period. We will do everything possible to see that your claim, and/or shortage is taken care of as fast as possible.

Refused Shipments:

Customers will be responsible for all shipping charges, storage fees and a 20% handling fee on all refused shipments. Merchandise refused that is not defective or damaged is subject to 20% restocking fee.

Prices:

We attempt to maintain all published prices as seen in the catalog, but due to the fact that we buy from hundreds of direct manufacturer, we can not control all product costs. If the supplier goes up, we are forced to raise our prices also. Consequently, our retail prices do change periodically and without notice. Please feel free to call for confirmation on current pricing.

Mailing List:

We maintain a mailing list by our sales history. If you are an active customer, you should be receiving periodic sales fliers and new item updates. The phone number you give us on your initial order will be used as your customer account number. If this number changes or you move, please send us a change of address form or call us so we may keep your current on our mailing list. We do not distribute your address, phone number or E-Mail address to outside sources.

GROUND SHIPPING & HANDLING CHART (Inside Continental U.S.A. - exc. Hawaii, Alaska, Puerto Rico)

Orders up to \$40.00 - add \$9.99	\$100.01 to \$300.00 -add 10%
\$40.01 to \$100.00 - add \$10.99	\$300.01 to \$500.00 -add 9%
	\$500.01 to \$800.00 -add 8%
	\$800.01 - UP -add 7%

Foreign Handling (per order) add \$20.00

Classic Chevrolet PARTS, Inc.

SUPPLIER OF QUALITY Chevrolet & GMC PARTS

Please print clearly and supply complete information. We must have a street address for FedEx or Motorfreight Delivery. They will not deliver to a P.O. Box. All orders will be shipped FedEx unless otherwise specified by you, the customer.

SOLD TO:

Name: _____

Address: _____

City: _____ State: _____

Zip Code: _____ Phone: _____

E-mail Address: _____

SHIP TO: (if different from above)

Name: _____

Address: _____

City: _____ State: _____

Zip Code: _____ Phone: _____

EFFECTIVE 2006

Order Toll Free (800) 354-4040
 24 Hour Fax Ordering (405) 631-5999
 Customer Service / Parts Department (405) 631-4400
 www.ClassicChevroletParts.com
 Monday-Friday 8 a.m. to 5 p.m. & Saturday 8 a.m. to 12 p.m. (CST)

METHOD OF PAYMENT - Please indicate your Choice

- () Personal Check () Cashiers Check () Money Order
 () VISA () MASTERCARD () DISCOVER

(If using credit card please fill out the following information)

Name on Card: _____

Signature: _____

Account Number: (_____ / _____ / _____ / _____)

Expiration Date: ____/____ V-Code (located on back of card) _____

Vehicle: _____

Year _____ Make _____

Order Qty	Part Number	Description	Item Price	Item Total
Example	BK-5000	Shop Manual	0	0

HOW SHALL WE SHIP:
 () FED-EX () AIR () US MAIL
 () TRUCK LINE

*Refer to the Back Side of this Order Form for Shipping Charges and Additional Info.
 Min. Shipping Charge \$9.99
 (Tax applicable to Okla. residents ONLY)*

Subtotal	
Shipping	
Insurance	
Okla. Sales Tax 8.375%	
Total	

ORDERING INFORMATION:

To Order By Mail:

We honor Personal Checks, Cashier's Checks, Money Orders, Discover, Visa, and MasterCard on any mail order. It is our goal to ship within 48 hours of receipt of your order. If we are out of stock on any item and hold your backorder until the part arrives for shipment. If the backorder extends over 30 days, we will notify you when the part arrives and request that you reorder (The exception to this is if you prepaid the order with a check or money order. In this instance the part will automatically be shipped upon arrival).

To Order By Telephone:

If you have your order ready, with part numbers in hand, please call out Toll Free Order Desk 1-800-354-4040. Our operators will gladly take your order. You can place your order on your **Discover, Visa, and MasterCard**. Again, please feel free to use our convenient Toll Free order lines for placing your order – but you must have your information ready. If you need technical assistance or do not have your part numbers, please call our parts department (405) 631-4400. Our parts team will assist you with any of your needs. We are open Monday thru Friday 8 a.m. to 5 p.m. and Saturday 8 a.m. to 12 p.m. (CST).

Shipping Charges:

All Fed Ex Ground Shipments within the continental United States will be charged according to the S&H chart below. Air shipments will be quoted upon ordering. All orders out of the United States quoted upon ordering. All orders too large to ship Fed Ex or USPS will be shipped Motor Freight. Consult with your salesperson for Motor Freight quotations at the time of placing your order. Heavy or Bulk items will require additional shipping charges. Hawaii, Alaska, Puerto Rico will be shipped Fed Ex 2nd Day Air.

Air Shipping Services:

Next Day Air, Second Day Air, and Third Day Select Shipping Charges are available on any order. Federal Express is currently our primary shipping source. For other shipping options consult with your Salesperson when ordering.

Return Information:

30-Day Return Policy. Inspect your order immediately upon arrival. Be sure you have received the parts you ordered and that they are free of any manufacturing defects. If there is a problem please call us at (405) 631-4400 for instructions. **All returned parts must have a letter of explanation of problem, and a copy of the invoice must accompany merchandise.** If possible, please include a daytime phone number in case we need to contact for further questions. **ALL FREIGHT MUST BE PREPAID.** We cannot accept COD's. If the reasons for the return is due our error, please include receipts of your cost for shipping back to us, so we may reimburse you for the freight. If a refund is requested and the reason of error is NOT due to our negligence a 20% restocking fee will be applied. The restocking fee is not applicable to In-Store credit or exchanges. We will not refund on any wood products, electrical items or special order items. No refunds will be accepted after 30 days from the date of the invoice. **IF YOU NEED ASSISTANCE WITH A RETURN PLEASE CALL OUR PARTS DEPARTMENT AT (405) 631-4400**, so we may assist you. Shipping costs are non-refundable.

Merchandise Damages and/or Shortages:

Inspect your order immediately upon arrival. If you should receive parts that are freight damaged or missing due to a broken box, contact the carrier that delivered the merchandise immediately (i.e. Fed Ex, Post Office, Freight Line etc.) All damaged and/or broken carton merchandise, must be held in the **ORIGINAL** container for inspection by the carrier. If Fed Ex shipped it, contact them for an inspection. If delivered by Motor Freight, count all cartons before signing for delivery and note any discrepancies on the bill of lading with your signature. **DO NOT RETURN DAMAGED MERCHANDISE TO US!!** The delivering carrier is responsible for any damages committed while your parts were in transit. If you should find a shortage in your box not due to broken or damaged delivery you **MUST** notify our parts department at (405) 631-4400 within 72 hours of receipt. We only accept responsibility for shortages reported within a 72-hour grace period. We will do everything possible to see that your claim, and/or shortage is taken care of as fast as possible.

Refused Shipments:

Customers will be responsible for all shipping charges, storage fees and a 20% handling fee on all refused shipments. Merchandise refused that is not defective or damaged is subject to 20% restocking fee.

Prices:

We attempt to maintain all published prices as seen in the catalog, but due to the fact that we buy from hundreds of direct manufacturer, we can not control all product costs. If the supplier goes up, we are forced to raise our prices also. Consequently, our retail prices do change periodically and without notice. Please feel free to call for confirmation on current pricing.

Mailing List:

We maintain a mailing list by our sales history. If you are an active customer, you should be receiving periodic sales fliers and new item updates. The phone number you give us on your initial order will be used as your customer account number. If this number changes or you move, please send us a change of address form or call us so we may keep your current on our mailing list. We do not distribute your address, phone number or E-Mail address to outside sources.

GROUND SHIPPING & HANDLING CHART (Inside Continental U.S.A. - exc. Hawaii, Alaska, Puerto Rico)

Orders up to \$40.00 - add \$9.99	\$100.01 to \$300.00 -add 10%
\$40.01 to \$100.00 - add \$10.99	\$300.01 to \$500.00 -add 9%
	\$500.01 to \$800.00 -add 8%
	\$800.01 - UP -add 7%

Foreign Handling (per order) add \$20.00

Classic Chevrolet PARTS, Inc.

SUPPLIER OF QUALITY Chevrolet & GMC PARTS

Please print clearly and supply complete information. We must have a street address for FedEx or Motorfreight Delivery. They will not deliver to a P.O. Box. All orders will be shipped FedEx unless otherwise specified by you, the customer.

SOLD TO:

Name: _____

Address: _____

City: _____ State: _____

Zip Code: _____ Phone: _____

E-mail Address: _____

SHIP TO: (if different from above)

Name: _____

Address: _____

City: _____ State: _____

Zip Code: _____ Phone: _____

EFFECTIVE 2006

Order Toll Free (800) 354-4040
 24 Hour Fax Ordering (405) 631-5999
 Customer Service / Parts Department (405) 631-4400
 www.ClassicChevroletParts.com
 Monday-Friday 8 a.m. to 5 p.m. & Saturday 8 a.m. to 12 p.m. (CST)

METHOD OF PAYMENT - Please indicate your Choice

Personal Check Cashiers Check Money Order

VISA MASTERCARD DISCOVER

(If using credit card please fill out the following information)

Name on Card: _____

Signature: _____

Account Number: (_____ / _____ / _____ / _____)

Expiration Date: ____/____/____ V-Code (located on back of card) _____

Vehicle: _____

Year _____ Make _____

Order Qty	Part Number	Description	Item Price	Item Total
Example	BK-5000	Shop Manual	0	0

HOW SHALL WE SHIP:
 FED-EX AIR US MAIL
 TRUCK LINE

*Refer to the Back Side of this Order Form for Shipping Charges and Additional Info.
 Min. Shipping Charge \$9.99
 (Tax applicable to Okla. residents ONLY)*

Subtotal	
Shipping	
Insurance	
Okla. Sales Tax 8.375%	
Total	

ORDERING INFORMATION:

To Order By Mail:

We honor Personal Checks, Cashier's Checks, Money Orders, Discover, Visa, and MasterCard on any mail order. It is our goal to ship within 48 hours of receipt of your order. If we are out of stock on any item and hold your backorder until the part arrives for shipment. If the backorder extends over 30 days, we will notify you when the part arrives and request that you reorder (The exception to this is if you prepaid the order with a check or money order. In this instance the part will automatically be shipped upon arrival).

To Order By Telephone:

If you have your order ready, with part numbers in hand, please call out Toll Free Order Desk 1-800-354-4040. Our operators will gladly take your order. You can place your order on your **Discover, Visa, and MasterCard**. Again, please feel free to use our convenient Toll Free order lines for placing your order – but you must have your information ready. If you need technical assistance or do not have your part numbers, please call our parts department (405) 631-4400. Our parts team will assist you with any of your needs. We are open Monday thru Friday 8 a.m. to 5 p.m. and Saturday 8 a.m. to 12 p.m. (CST).

Shipping Charges:

All Fed Ex Ground Shipments within the continental United States will be charged according to the S&H chart below. Air shipments will be quoted upon ordering. All orders out of the United States quoted upon ordering. All orders too large to ship Fed Ex or USPS will be shipped Motor Freight. Consult with your salesperson for Motor Freight quotations at the time of placing your order. Heavy or Bulk items will require additional shipping charges. Hawaii, Alaska, Puerto Rico will be shipped Fed Ex 2nd Day Air.

Air Shipping Services:

Next Day Air, Second Day Air, and Third Day Select Shipping Charges are available on any order. Federal Express is currently our primary shipping source. For other shipping options consult with your Salesperson when ordering.

Return Information:

30-Day Return Policy. Inspect your order immediately upon arrival. Be sure you have received the parts you ordered and that they are free of any manufacturing defects. If there is a problem please call us at (405) 631-4400 for instructions. **All returned parts must have a letter of explanation of problem, and a copy of the invoice must accompany merchandise.** If possible, please include a daytime phone number in case we need to contact for further questions. **ALL FREIGHT MUST BE PREPAID.** We cannot accept COD's. If the reasons for the return is due our error, please include receipts of your cost for shipping back to us, so we may reimburse you for the freight. If a refund is requested and the reason of error is NOT due to our negligence a 20% restocking fee will be applied. The restocking fee is not applicable to In-Store credit or exchanges. We will not refund on any wood products, electrical items or special order items. No refunds will be accepted after 30 days from the date of the invoice. **IF YOU NEED ASSISTANCE WITH A RETURN PLEASE CALL OUR PARTS DEPARTMENT AT (405) 631-4400**, so we may assist you. Shipping costs are non-refundable.

Merchandise Damages and/or Shortages:

Inspect your order immediately upon arrival. If you should receive parts that are freight damaged or missing due to a broken box, contact the carrier that delivered the merchandise immediately (i.e. Fed Ex, Post Office, Freight Line etc.) All damaged and/or broken carton merchandise, must be held in the **ORIGINAL** container for inspection by the carrier. If Fed Ex shipped it, contact them for an inspection. If delivered by Motor Freight, count all cartons before signing for delivery and note any discrepancies on the bill of lading with your signature. **DO NOT RETURN DAMAGED MERCHANDISE TO US!!** The delivering carrier is responsible for any damages committed while your parts were in transit. If you should find a shortage in your box not due to broken or damaged delivery you **MUST** notify our parts department at (405) 631-4400 within 72 hours of receipt. We only accept responsibility for shortages reported within a 72-hour grace period. We will do everything possible to see that your claim, and/or shortage is taken care of as fast as possible.

Refused Shipments:

Customers will be responsible for all shipping charges, storage fees and a 20% handling fee on all refused shipments. Merchandise refused that is not defective or damaged is subject to 20% restocking fee.

Prices:

We attempt to maintain all published prices as seen in the catalog, but due to the fact that we buy from hundreds of direct manufacturer, we can not control all product costs. If the supplier goes up, we are forced to raise our prices also. Consequently, our retail prices do change periodically and without notice. Please feel free to call for confirmation on current pricing.

Mailing List:

We maintain a mailing list by our sales history. If you are an active customer, you should be receiving periodic sales fliers and new item updates. The phone number you give us on your initial order will be used as your customer account number. If this number changes or you move, please send us a change of address form or call us so we may keep your current on our mailing list. We do not distribute your address, phone number or E-Mail address to outside sources.

GROUND SHIPPING & HANDLING CHART (Inside Continental U.S.A. - exc. Hawaii, Alaska, Puerto Rico)

Orders up to \$40.00 - add \$9.99	\$100.01 to \$300.00 -add 10%
\$40.01 to \$100.00 - add \$10.99	\$300.01 to \$500.00 -add 9%
	\$500.01 to \$800.00 -add 8%
	\$800.01 - UP -add 7%

Foreign Handling (per order) add \$20.00

Classic Chevrolet PARTS, Inc.

SUPPLIER OF QUALITY Chevrolet & GMC PARTS

Please print clearly and supply complete information. We must have a street address for FedEx or Motorfreight Delivery. They will not deliver to a P.O. Box. All orders will be shipped FedEx unless otherwise specified by you, the customer.

SOLD TO:

Name: _____

Address: _____

City: _____ State: _____

Zip Code: _____ Phone: _____

E-mail Address: _____

SHIP TO: (if different from above)

Name: _____

Address: _____

City: _____ State: _____

Zip Code: _____ Phone: _____

EFFECTIVE 2006

Order Toll Free (800) 354-4040
 24 Hour Fax Ordering (405) 631-5999
 Customer Service / Parts Department (405) 631-4400
 www.ClassicChevroletParts.com
 Monday-Friday 8 a.m. to 5 p.m. & Saturday 8 a.m. to 12 p.m. (CST)

METHOD OF PAYMENT - Please indicate your Choice

Personal Check Cashiers Check Money Order
 VISA MASTERCARD DISCOVER

(If using credit card please fill out the following information)

Name on Card: _____

Signature: _____

Account Number: (_____ / _____ / _____ / _____)

Expiration Date: ____/____/____ V-Code (located on back of card) _____

Vehicle: _____

Year _____ Make _____

Order Qty	Part Number	Description	Item Price	Item Total
Example	BK-5000	Shop Manual	0	0

HOW SHALL WE SHIP:
 FED-EX AIR US MAIL
 TRUCK LINE

*Refer to the Back Side of this Order Form for Shipping Charges and Additional Info.
 Min. Shipping Charge \$9.99
 (Tax applicable to Okla. residents ONLY)*

Subtotal	
Shipping	
Insurance	
Okla. Sales Tax 8.375%	
Total	

ORDERING INFORMATION:

To Order By Mail:

We honor Personal Checks, Cashier's Checks, Money Orders, Discover, Visa, and MasterCard on any mail order. It is our goal to ship within 48 hours of receipt of your order. If we are out of stock on any item and hold your backorder until the part arrives for shipment. If the backorder extends over 30 days, we will notify you when the part arrives and request that you reorder (The exception to this is if you prepaid the order with a check or money order. In this instance the part will automatically be shipped upon arrival).

To Order By Telephone:

If you have your order ready, with part numbers in hand, please call out Toll Free Order Desk 1-800-354-4040. Our operators will gladly take your order. You can place your order on your **Discover, Visa, and MasterCard**. Again, please feel free to use our convenient Toll Free order lines for placing your order – but you must have your information ready. If you need technical assistance or do not have your part numbers, please call our parts department (405) 631-4400. Our parts team will assist you with any of your needs. We are open Monday thru Friday 8 a.m. to 5 p.m. and Saturday 8 a.m. to 12 p.m. (CST).

Shipping Charges:

All Fed Ex Ground Shipments within the continental United States will be charged according to the S&H chart below. Air shipments will be quoted upon ordering. All orders out of the United States quoted upon ordering. All orders too large to ship Fed Ex or USPS will be shipped Motor Freight. Consult with your salesperson for Motor Freight quotations at the time of placing your order. Heavy or Bulk items will require additional shipping charges. Hawaii, Alaska, Puerto Rico will be shipped Fed Ex 2nd Day Air.

Air Shipping Services:

Next Day Air, Second Day Air, and Third Day Select Shipping Charges are available on any order. Federal Express is currently our primary shipping source. For other shipping options consult with your Salesperson when ordering.

Return Information:

30-Day Return Policy. Inspect your order immediately upon arrival. Be sure you have received the parts you ordered and that they are free of any manufacturing defects. If there is a problem please call us at (405) 631-4400 for instructions. **All returned parts must have a letter of explanation of problem, and a copy of the invoice must accompany merchandise.** If possible, please include a daytime phone number in case we need to contact for further questions. **ALL FREIGHT MUST BE PREPAID.** We cannot accept COD's. If the reasons for the return is due our error, please include receipts of your cost for shipping back to us, so we may reimburse you for the freight. If a refund is requested and the reason of error is NOT due to our negligence a 20% restocking fee will be applied. The restocking fee is not applicable to In-Store credit or exchanges. We will not refund on any wood products, electrical items or special order items. No refunds will be accepted after 30 days from the date of the invoice. **IF YOU NEED ASSISTANCE WITH A RETURN PLEASE CALL OUR PARTS DEPARTMENT AT (405) 631-4400**, so we may assist you. Shipping costs are non-refundable.

Merchandise Damages and/or Shortages:

Inspect your order immediately upon arrival. If you should receive parts that are freight damaged or missing due to a broken box, contact the carrier that delivered the merchandise immediately (i.e. Fed Ex, Post Office, Freight Line etc.) All damaged and/or broken carton merchandise, must be held in the **ORIGINAL** container for inspection by the carrier. If Fed Ex shipped it, contact them for an inspection. If delivered by Motor Freight, count all cartons before signing for delivery and note any discrepancies on the bill of lading with your signature. **DO NOT RETURN DAMAGED MERCHANDISE TO US!!** The delivering carrier is responsible for any damages committed while your parts were in transit. If you should find a shortage in your box not due to broken or damaged delivery you **MUST** notify our parts department at (405) 631-4400 within 72 hours of receipt. We only accept responsibility for shortages reported within a 72-hour grace period. We will do everything possible to see that your claim, and/or shortage is taken care of as fast as possible.

Refused Shipments:

Customers will be responsible for all shipping charges, storage fees and a 20% handling fee on all refused shipments. Merchandise refused that is not defective or damaged is subject to 20% restocking fee.

Prices:

We attempt to maintain all published prices as seen in the catalog, but due to the fact that we buy from hundreds of direct manufacturer, we can not control all product costs. If the supplier goes up, we are forced to raise our prices also. Consequently, our retail prices do change periodically and without notice. Please feel free to call for confirmation on current pricing.

Mailing List:

We maintain a mailing list by our sales history. If you are an active customer, you should be receiving periodic sales fliers and new item updates. The phone number you give us on your initial order will be used as your customer account number. If this number changes or you move, please send us a change of address form or call us so we may keep your current on our mailing list. We do not distribute your address, phone number or E-Mail address to outside sources.

GROUND SHIPPING & HANDLING CHART (Inside Continental U.S.A. - exc. Hawaii, Alaska, Puerto Rico)

Orders up to \$40.00 - add \$9.99	\$100.01 to \$300.00 -add 10%
\$40.01 to \$100.00 - add \$10.99	\$300.01 to \$500.00 -add 9%
	\$500.01 to \$800.00 -add 8%
	\$800.01 - UP -add 7%

Foreign Handling (per order) add \$20.00

Classic Chevrolet PARTS, Inc.

SUPPLIER OF QUALITY Chevrolet & GMC PARTS

Please print clearly and supply complete information. We must have a street address for FedEx or Motorfreight Delivery. They will not deliver to a P.O. Box. All orders will be shipped FedEx unless otherwise specified by you, the customer.

SOLD TO:

Name: _____

Address: _____

City: _____ State: _____

Zip Code: _____ Phone: _____

E-mail Address: _____

SHIP TO: (if different from above)

Name: _____

Address: _____

City: _____ State: _____

Zip Code: _____ Phone: _____

EFFECTIVE 2006

Order Toll Free (800) 354-4040

24 Hour Fax Ordering (405) 631-5999

Customer Service / Parts Department (405) 631-4400

www.ClassicChevroletParts.com

Monday-Friday 8 a.m. to 5 p.m. & Saturday 8 a.m. to 12 p.m. (CST)

METHOD OF PAYMENT - Please indicate your Choice

Personal Check Cashiers Check Money Order

VISA MASTERCARD DISCOVER

(If using credit card please fill out the following information)

Name on Card: _____

Signature: _____

Account Number: (_____ / _____ / _____ / _____)

Expiration Date: ____/____ V-Code (located on back of card) _____

Vehicle: _____

Year _____ Make _____

Order Qty	Part Number	Description	Item Price	Item Total
Example	BK-5000	Shop Manual	0	0

HOW SHALL WE SHIP:

FED-EX AIR US MAIL
 TRUCK LINE

*Refer to the Back Side of this Order Form for Shipping Charges and Additional Info.
 Min. Shipping Charge \$9.99
 (Tax applicable to Okla. residents ONLY)*

Subtotal	
Shipping	
Insurance	
Okla. Sales Tax 8.375%	
Total	

ORDERING INFORMATION:

To Order By Mail:

We honor Personal Checks, Cashier's Checks, Money Orders, Discover, Visa, and MasterCard on any mail order. It is our goal to ship within 48 hours of receipt of your order. If we are out of stock on any item and hold your backorder until the part arrives for shipment. If the backorder extends over 30 days, we will notify you when the part arrives and request that you reorder (The exception to this is if you prepaid the order with a check or money order. In this instance the part will automatically be shipped upon arrival).

To Order By Telephone:

If you have your order ready, with part numbers in hand, please call out Toll Free Order Desk 1-800-354-4040. Our operators will gladly take your order. You can place your order on your **Discover, Visa, and MasterCard**. Again, please feel free to use our convenient Toll Free order lines for placing your order – but you must have your information ready. If you need technical assistance or do not have your part numbers, please call our parts department (405) 631-4400. Our parts team will assist you with any of your needs. We are open Monday thru Friday 8 a.m. to 5 p.m. and Saturday 8 a.m. to 12 p.m. (CST).

Shipping Charges:

All Fed Ex Ground Shipments within the continental United States will be charged according to the S&H chart below. Air shipments will be quoted upon ordering. All orders out of the United States quoted upon ordering. All orders too large to ship Fed Ex or USPS will be shipped Motor Freight. Consult with your salesperson for Motor Freight quotations at the time of placing your order. Heavy or Bulk items will require additional shipping charges. Hawaii, Alaska, Puerto Rico will be shipped Fed Ex 2nd Day Air.

Air Shipping Services:

Next Day Air, Second Day Air, and Third Day Select Shipping Charges are available on any order. Federal Express is currently our primary shipping source. For other shipping options consult with your Salesperson when ordering.

Return Information:

30-Day Return Policy. Inspect your order immediately upon arrival. Be sure you have received the parts you ordered and that they are free of any manufacturing defects. If there is a problem please call us at (405) 631-4400 for instructions. **All returned parts must have a letter of explanation of problem, and a copy of the invoice must accompany merchandise.** If possible, please include a daytime phone number in case we need to contact for further questions. **ALL FREIGHT MUST BE PREPAID.** We cannot accept COD's. If the reasons for the return is due our error, please include receipts of your cost for shipping back to us, so we may reimburse you for the freight. If a refund is requested and the reason of error is NOT due to our negligence a 20% restocking fee will be applied. The restocking fee is not applicable to In-Store credit or exchanges. We will not refund on any wood products, electrical items or special order items. No refunds will be accepted after 30 days from the date of the invoice. **IF YOU NEED ASSISTANCE WITH A RETURN PLEASE CALL OUR PARTS DEPARTMENT AT (405) 631-4400**, so we may assist you. Shipping costs are non-refundable.

Merchandise Damages and/or Shortages:

Inspect your order immediately upon arrival. If you should receive parts that are freight damaged or missing due to a broken box, contact the carrier that delivered the merchandise immediately (i.e. Fed Ex, Post Office, Freight Line etc.) All damaged and/or broken carton merchandise, must be held in the **ORIGINAL** container for inspection by the carrier. If Fed Ex shipped it, contact them for an inspection. If delivered by Motor Freight, count all cartons before signing for delivery and note any discrepancies on the bill of lading with your signature. **DO NOT RETURN DAMAGED MERCHANDISE TO US!!** The delivering carrier is responsible for any damages committed while your parts were in transit. If you should find a shortage in your box not due to broken or damaged delivery you **MUST** notify our parts department at (405) 631-4400 within 72 hours of receipt. We only accept responsibility for shortages reported within a 72-hour grace period. We will do everything possible to see that your claim, and/or shortage is taken care of as fast as possible.

Refused Shipments:

Customers will be responsible for all shipping charges, storage fees and a 20% handling fee on all refused shipments. Merchandise refused that is not defective or damaged is subject to 20% restocking fee.

Prices:

We attempt to maintain all published prices as seen in the catalog, but due to the fact that we buy from hundreds of direct manufacturer, we can not control all product costs. If the supplier goes up, we are forced to raise our prices also. Consequently, our retail prices do change periodically and without notice. Please feel free to call for confirmation on current pricing.

Mailing List:

We maintain a mailing list by our sales history. If you are an active customer, you should be receiving periodic sales fliers and new item updates. The phone number you give us on your initial order will be used as your customer account number. If this number changes or you move, please send us a change of address form or call us so we may keep your current on our mailing list. We do not distribute your address, phone number or E-Mail address to outside sources.

GROUND SHIPPING & HANDLING CHART (Inside Continental U.S.A. - exc. Hawaii, Alaska, Puerto Rico)

Orders up to \$40.00 - add \$9.99	\$100.01 to \$300.00 -add 10%
\$40.01 to \$100.00 - add \$10.99	\$300.01 to \$500.00 -add 9%
	\$500.01 to \$800.00 -add 8%
	\$800.01 - UP -add 7%

Foreign Handling (per order) add \$20.00